



Thermo Scientific Alpha Process Products



Thermo Scientific Alpha 800/1000 Series Controllers
• pH • ORP • Conductivity • Resistivity • Dissolved Oxygen



One Source. Total Solution

Recognised internationally for industry-leading quality and accuracy, companies all over the world choose Thermo Scientific Process Products for reliable process monitoring and control across a broad range of water and wastewater applications:

- Wastewater Treatment
- Drinking Water
- Chemical Processing
- F&B Manufacturing
- Seawater Desalination
- Pharmaceutical
- Power
- Electroplating
- Semiconductor

Consistent monitoring and control of water quality are vital in many industries. Thermo Scientific products are built to stand up to the demands of on-line continuous use, even under the most severe conditions. With the Alpha 1000 series, Thermo Scientific brings electrochemical processes in water and wastewater applications to a new level of reliability and versatility, offering flexible process control at an excellent price point.

Whether it's pH, ORP, Conductivity or Dissolved Oxygen you are measuring, the Alpha 1000 series delivers, accurately and consistently. Because at Thermo Scientific, reliability and ease-of-use aren't just features – they're fundamentals.

Reliability and ease-of-use aren't just features – they're fundamentals

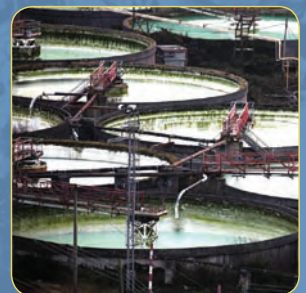



Thermo Scientific Alpha 1000 Series Controllers/Transmitters:

The Controllers/Transmitters:

Reliable, highly-customisable, and easy to use – each Thermo Scientific Alpha pH 800 and Alpha 1000 series controller/transmitter is equipped with a customized microprocessor – the Application Specific Integrated Circuit (ASIC) - and offers powerful features through the menu-driven SETUP program. Thoughtfully designed with a simple jumper selection for 110/220 VAC power supply, the Alpha 1000 series controllers can be used anywhere in the world, wherever there is demand for water quality measurement and control.

- The **Alpha pH 800** offers six sub menus in its menu-driven SETUP program, allowing easy configuration of controller for effective limit control of pH or ORP
- The **Alpha pH 1000** features direct, online auto-calibration with choice of NIST or USA buffer standards. Electrode status is displayed after each successful calibration
- Select Conductivity range and cell constant directly via the keypad of **Alpha COND 1000** – Controller measures across ten Conductivity ranges from 0.000 $\mu\text{S}/\text{cm}$ to 199.9 mS/cm
- The **Alpha RES 1000** measures at $\pm 1\%$ full-scale accuracy across 2 Resistivity ranges, and is equipped to measure ultrapure or RO water applications

- The **Alpha DO 1000** accepts low range probes (0 to 10 ppm) and general range probes (0.5 to 40 ppm) to suit a wide range of applications

The Electrodes:

Thermo Scientific offers a wide selection of process electrodes, buffer, standards and accessories to complement your process requirements.

- High-quality, double-junction **pH and ORP electrodes** with Kynar[®] or Annular PTFE reference junctions operate in environment from 0 °C up to 110 °C. Each electrode comes with integral low-noise semi-conductor cables (unless otherwise stated)
- 2-cell **Conductivity electrodes** that incorporate 3-wire Pt100 for automatic temperature compensation. Durable, low maintenance electrodes built with Titanium or SS316 give consistent performances in high ambient temperature of up to 120 °C
- **Dissolved Oxygen electrodes** designed for minimal maintenance and quick, stable readings within short response time. Rugged and long-lasting galvanic electrodes requires no warm-up time; low maintenance amperometric electrodes capture DO readings as low as 0.01 ppm

Main Features:

Front Panel



IP54 Front Panel Housing

Push-Button Calibration

Quick, convenient and easy

Menu-Driven Controls

With intuitive prompts and electrode offset adjustment from keypad connectors

Large UV Light-Protected LCD Display with Backlight

For easy reading, even in dark places

Bi-Colour LEDs

Clearly indicates relay status and mode of operation. Visible even from a distance

Manual Override

Facilitates quick processing with direct control on dosing pumps

Automatic Temperature Compensation

Or manual temperature compensation without ATC probe. 3-wire system ensures minimal errors from temperature electrode and cables. Independent settings for calibration and process temperatures for accurate temperature compensation

Three SPDT Relays

Two Independent Relays A & B

allow combination of high and low settings

Alarm Relay Doubles Up As Wash Relay* for periodical, automated cleansing of electrodes – essential for accurate measurements

Single-Pole-Double-Throw (SPDT) Alarm Relay* alerts when readings fall outside set points. Comes with user-customisable time-delay for minimal false alarms

*Available in Alpha 1000 Series Only

Back Panel

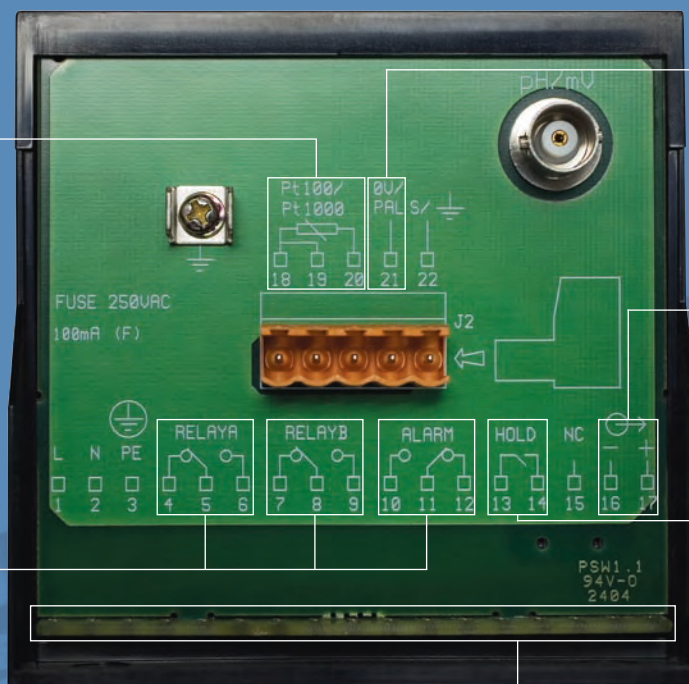

Liquid Ground

Symmetrical Operation Mode (for pH/ORP measurements only) for accurate readings in electrically noisy environments

4-20 mA or 0-20 mA Current Outputs

Fully scaleable, galvanically-isolated outputs for parameter measurements

Hold Function

for Master-Slave Operation, so one controller can control the actions of a second controller

Detachable Plug In Connectors

for quick, easy wiring independent of the controller



Thermo Scientific Alpha pH 800 & pH 1000 pH/ORP Controller/Transmitter:

pH/ORP:

The Alpha pH 800 and pH 1000 controllers/transmitters combines consistent performance and sophisticated control functions with user-friendly features. Meters come with seven preset buffer values for quick, accurate auto-calibration; electrode offset function allows direct reading corrections without needing to remove electrode from the control system. Alarm delay and individual set-point hystereses in limit control mode prevent chattering, false alarms, and unnecessary down time.

For finer control, Alpha pH 1000 offers proportional pulse length control and proportional pulse frequency control, in addition to basic limit control.

- 2-in-1 controllers/transmitters can be configured to measure either pH or ORP (mV or %)
- Auto-calibration with choice of NIST or USA buffer selection. Electrode slope and offset is displayed after each successful calibration















- Symmetrical mode option for clear, uninterrupted pH readings in electronically noisy environment
- Antimony mode option for use with antimony electrodes in applications that involves corrosive Hydrofluoric Acid
- Option of Auto or Manual Temperature Compensation. Three-wire system compensates for cable-length resistance errors
- Galvanically-isolated, scaleable 0/4 to 20 mA output for high-quality output on peripheral devices
- Alpha pH 1000 limit/proportional controller also offer two additional features: wash function for scheduled electrode wash, and alarm relay function to alert when measurement crosses the set points





Symmetrical mode option for accurate measurements, even in electronically noisy environments

Specification Information

pH/ORP Controller/Transmitter	Alpha pH 1000		Alpha pH 800		
	Order Code	TSCTP1001	TSCTP1002	TSCTP0801	TSCTP0802
Part No.	01X208616	01X208617	01X252309	01X252310	
pH:					
Range:	-2.00 to 16.00 pH				
Resolution:	0.01 pH				
Accuracy:	±0.01 pH				
ORP:					
Range:	-1000 to 1000 mV / 0 to 100.0 %		-1000 to 1000 mV		
Resolution:	1 mV / 0.1 %		1 mV		
Accuracy:	±1 mV / ±0.2 %		±1 mV		
Temperature:					
Range:	-9.9 to 125.0 °C				
Resolution:	0.1 °C				
Accuracy:	±0.5 °C				
Sensor:	Pt100 / Pt1000 (jumper selectable); 2 or 3 wire				
Compensation:	Auto/manual				
Set point & controller functions:					
Set point 1 (SP1) / set point 2 (SP2):	0.00 to 14.00 pH or -1000 to 1000 mV or 0 to 100 %		-2.00 to 16.00 pH or -1000 to 1000 mV		
Switching pH hysteresis:	0.1 to 1 pH				
Switching ORP hysteresis:	10 to 100 mV / 1 to 10.0 %		10 to 100 mV		
Function (switchable):	P control (pulse length/pulse frequency); limit control		Limit control		
Adjustable period with pulse length controller:	0.5 to 20 sec		-		
Adjustable period with pulse frequency controller:	60 to 120 pulse/min		-		
Pickup/dropout delay:	0 to 2000 sec				
Contact outputs:	3 SPDT relays		2 SPDT relays		
Switching voltage/current/power:	Max. 250 VAC / max. 3 A / max. 600 VA				
Alarm functions:					
Function (switchable):	Steady or fleet (pulse)		-		
Wash cycle:	0.1 to 199.9 hr		-		
Wash duration:	1 to 1999 sec		-		
Pickup delay:	0 to 2000 sec		-		
Switching voltage/current/power:	Max. 250 VAC / max. 3 A / max. 600 VA		-		
Electrical data & connections:					
Transmitter function:	0/4 to 20 mA scalable outputs for pH/ORP, galvanically isolated				
Hold function switch:	To freeze output current and deactivate control relays				
Load:	Max. 600 Ω		Max. 500 Ω		
pH/ORP input:	BNC (10 ¹² impedance); asymmetrical/symmetrical				
Connection terminal:	5-pole, 17-pole terminal, detachable blocks				
Display:					
LCD:	7 segments display with symbols for status information				
Power supply:					
Input:	110 VAC (jumper selectable); 48 to 62 Hz; max. 7 VA	220 VAC (jumper selectable); 48 to 62 Hz; max. 7 VA	110 VAC (jumper selectable); 48 to 62 Hz; max. 0.75 VA	220 VAC (jumper selectable); 48 to 62 Hz; max. 0.75 VA	
Main fuse:	Slow-blow 250 V / 100 mA				
Pollution degree:	2				
Transient overvoltage category:	II				
EMC specifications:					
Emitted interference:	According to EN 50081-1				
Immunity to interference:	According to EN 50082-1				
Environmental conditions:					
Operating temperature range:	-10 to 50 °C				
Max. relative humidity:	80 % up to 31 °C decreasing linearly to 50 % at 40 °C				
Mechanical specifications:					
Dimensions (WxHxD):	96 x 96 x 175 mm				
Weight:	700 g (unit) / 800 g (packed)				
Ingress protection:	IP54 (front panel)				

pH/ORP Electrodes

Order Code	EC100GTS020B	EC100GTS010B	EC100GTS005B	ECARGTS005B	ECARHTTS005B	ECARTSOHF05B	ECARTS005B
Part No.	93X417005	93X417006	93X218865	93X218864	93X218860	93X218872	93X218859
pH Electrodes							
							
Classification	pH						
pH range	0 to 14					0 to 14, HF resistant	0 to 14
Reference	Annular PTFE, double junction						
Reference electrolyte	Saturated KCl, polymerized gel						
Operating temperature	0 to 80 °C / 32 to 176 °F				0 to 110 °C / 32 to 230 °F high temp.	0 to 80 °C / 32 to 176 °F	
Pressure tolerance	6 bars (87 psi)				9 bars (130 psi)	6 bars (87 psi)	
Temperature sensor	Pt100				-		
Potential matching pin/liquid ground	Platinum				-		
Material	PPS (Ryton®)						
Thread	¾" NPT						
Cable	Integral 20 m (65.6 ft) low-noise semi-conductor screened	Integral 10 m (32.8 ft) low-noise semi-conductor screened	Integral 5 m (16.4 ft) low-noise semi-conductor screened				
Connector	BNC						
Dimensions	Length	151 mm (excludes cable)					
	Diameter	26 mm (external)					
Weight	950 g	850 g	650 g				430 g

Order Code	ECHTAUTS005B		ECHTPPTS005B	
Part No.	93X219128		93X219126	
ORP Electrodes				
				
Classification	Gold		Platinum	
Sensor	Gold		Platinum	
ORP range	±1000 mV			
Reference	Annular PTFE, double junction			
Reference electrolyte	Saturated KCl, polymerized gel			
Operating temperature	0 to 80 °C / 32 to 176 °F			
Pressure tolerance	6 bars (87 psi)			
Potential matching pin/liquid ground	Platinum			
Material	PPS (Ryton®)			
Thread	¾" NPT			
Cable	Integral 5 m (16.4 ft) low-noise semi-conductor screened			
Connector	BNC			
Dimensions	Length	151 mm (excludes cable)		
	Diameter	26 mm (external)		
Weight	430 g			

Electrode Selection Guide

pH/ORP Electrodes	EC100GTSO20B 93X417005	EC100GTSO10B 93X417006	EC100GTSO-05B 93X218865	ECARGTSO-05B 93X218864	ECARHTTSO-05B 93X218860	ECARTSOHF-05B 93X218872	ECARTSO-05B 93X218859	ECHTAUTSO05B 93X219128	ECHPTTSO05B 93X219126
General pH measurement	•	•	•	•	•	•	•		
pH measurement with ATC	•	•	•	•					
pH measurement in noisy environment eg. electroplating	•	•	•	•					
pH measurement at high temperatures (up to 110 °C/230 °F ; 9 bar/130 psi)					•				
pH measurement in the presence of Hydrofluoric Acid (HF)						•			
General ORP/Redox measurement								•	•
ORP measurement in noisy environment								•	•
ORP measurement in Cyanide treatment								•	
ORP measurements in oxidising applications (above 500 mV)									•
ORP measurements in reducing applications (below 500 mV)								•	

Line Diagram (All dimensions are in mm unless specified otherwise)

pH/ORP Electrodes

EC100GTSO20B
EC100GTSO10B
EC100GTSO05B
ECARGTSO05B
ECARTSOHF05B
ECARTSO05B
ECHTAUTSO05B
ECHPTTSO05B

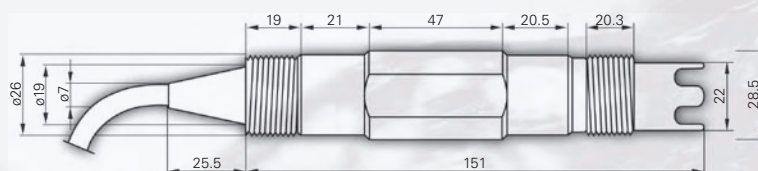

Ordering Information

Order Code	Part Number	Description
TSPHCTP1001	01X208616	Alpha pH 1000 panel-mount pH/ORP controller/transmitter with 110 VAC setting. Incl. elbow BNC connector, terminal blocks, gasket, threaded rods, catch, etc
TSPHCTP1002	01X208617	Alpha pH 1000 panel-mount pH/ORP controller/transmitter with 220 VAC setting. Incl. elbow BNC connector, terminal blocks, gasket, threaded rods, catch, etc
TSPHCTP0801	01X252309	Alpha pH 800 panel-mount pH/ORP controller/transmitter with 110 VAC setting. Incl. elbow BNC connector, terminal blocks, gasket, threaded rods, catch, etc
TSPHCTP0802	01X252310	Alpha pH 800 panel-mount pH/ORP controller/transmitter with 220 VAC setting. Incl. elbow BNC connector, terminal blocks, gasket, threaded rods, catch, etc
EC100GTSO20B	93X417005	Ryton®-body pH combi electrode with Pt100 RTD (ATC) & 20 m cable with BNC & PMP
EC100GTSO10B	93X417006	Ryton®-body pH combi electrode with Pt100 RTD (ATC) & 10 m cable with BNC & PMP
EC100GTSO05B	93X218865	Ryton®-body pH combi electrode with Pt100 RTD (ATC) & 5 m cable with BNC & PMP
ECARGTSO05B	93X218864	Ryton®-body pH combi electrode with 5 m cable with BNC & connector for PMP (no ATC)
ECARHTTSO05B	93X218860	Ryton®-body pH combi electrode with 5 m cable with BNC connector (no ATC); measures up to 110 °C
ECARTSOHF05B	93X218872	Ryton®-body pH combi electrode without ATC & 5 m cable with BNC connector. HF resistant glass
ECARTSO05B	93X218859	Ryton®-body pH combi electrode with 5 m cable with BNC connector (no ATC)
ECHTAUTSO05B	93X219128	Ryton®-body ORP gold electrode with 5 m cable with BNC & PMP (no ATC)
ECHPTTSO05B	93X219126	Ryton®-body ORP platinum electrode with 5 m cable with BNC & PMP (no ATC)
ECCBL05SMK50	01X222801	Low-noise 50 m coaxial SMK cable for pH/ORP electrodes (without ATC), 5 mm, open-ended with no connectors
28X088001	28X088001	Male BNC connector for 5 mm extension cable; 1 unit (need BNC crimping tool to connect to extension cable)
ECCBL030510	01X222802	Low-noise 10 m coaxial cable for pH/ORP electrodes (without ATC; with PMP), 3 mm/5 mm, male-male BNC connectors (for extending ECARGTSO05, ECHTAUTSO05B & ECHPTTSO05B)
ECCBL030520	01X222803	Low-noise 20 m coaxial cable for pH/ORP electrodes (without ATC; with PMP), 3 mm/5 mm, male-male BNC connectors (for extending ECARGTSO05, ECHTAUTSO05B & ECHPTTSO05B)
ECCONBNCBNC	01X243102	BNC to BNC adapter (for extension of cable connection) – a pack of 10 units
ECAC021011	81X220801	CPVC electrode tee for pH/ORP electrodes with ¾" to 1" adapter
ECAK061014	81X220802	Kynar® electrode tee for pH/ORP electrodes with ¾" to 1" adapter
ECPREAMP	01X228601	Pre-amplifier (for cable length exceeding 25 m) with female-female BNC connectors at each side of the junction box; batteries included
ECPHSIMULATOR	01X373301	Precision hi-low impedance & multiple buffers pH simulator (with BNC-BNC cable provided)



Thermo Scientific Alpha COND 1000 Conductivity Controller/Transmitter:

Conductivity:

The Alpha COND 1000 features up to ten selectable conductivity ranges and corresponding cell constant K values, easily configured through a six-button keypad. Adjustable temperature co-efficient and ultrapure water compensation option allow measurements in broad-range applications, from ultrapure water to high-conductivity samples.

















- $\pm 1\%$ full scale accuracy across ten different Conductivity ranges
- Adjustable temperature coefficient from 0.0 to 10.0% for higher accuracy
- Pure water compensation option corrects non-linearity of pure water temperature correction curves in ultrapure water applications
- Option of Auto or Manual Temperature Compensation. Three-wire system compensates for cable-length resistance errors
- Meter displays electrode information after each successful calibration. Previous calibration data is retained in the event of unsuccessful calibrations
- Line adjustment feature corrects long cable resistance errors – an important feature useful in applications involving high conductivity measurements
- Galvanically-isolated, scaleable 0/4 to 20 mA output for high-quality output on peripheral devices

$\pm 1\%$ full scale accuracy across ten conductivity ranges – even in pure water applications

Specification Information

Conductivity Controller/Transmitter		Alpha COND 1000	
Order Code	TSCONCTP1001	TSCONCTP1002	
Part No.	01X216017	01X216018	
Conductivity:			
Range:	... to 1.999 $\mu\text{S/cm}$; ... to 19.99 $\mu\text{S/cm}$; ... to 199.9 $\mu\text{S/cm}$; ... to 1999 $\mu\text{S/cm}$; ... to 5000 $\mu\text{S/cm}$; ... to 19.99 mS/cm ; ... to 199.9 mS/cm		
Resolution:	0.001 $\mu\text{S/cm}$; 0.01 $\mu\text{S/cm}$; 0.1 $\mu\text{S/cm}$; 1 $\mu\text{S/cm}$; 5 $\mu\text{S/cm}$; 0.01 mS/cm ; 0.1 mS/cm		
Accuracy:	± 1 % full scale reading		
Cell constant:	0.01; 0.1; 1; 10		
Temperature:			
Range:	-9.9 to 125 $^{\circ}\text{C}$		
Resolution:	0.1 $^{\circ}\text{C}$		
Accuracy:	± 0.5 $^{\circ}\text{C}$		
Sensor:	Pt100 / Pt1000 (jumper selectable)		
Compensation:	Auto/manual (normalized at 25 $^{\circ}\text{C}$)		
Coefficient:	Ultrapure water or linear 0.00 to 10.00 %		
Set point & controller functions:			
Set point 1 (SP1) / set point 2 (SP2):	... to 1.999 $\mu\text{S/cm}$ or ... to 19.99 $\mu\text{S/cm}$ or ... to 199.9 $\mu\text{S/cm}$ or ... to 5000 $\mu\text{S/cm}$ or ... to 19.99 mS/cm or ... to 199.9 mS/cm		
Switching Conductivity hysteresis:	0 to 10 % of full scale		
Function (switchable):	P control (pulse length/pulse frequency); limit control		
Adjustable period with pulse length controller:	0.5 to 20 sec		
Adjustable period with pulse frequency controller:	60 to 120 pulse/min		
Pickup/dropout delay:	0 to 2000 sec		
Contact outputs:	3 SPDT relays		
Switching voltage/current/power:	Max. 250 VAC / max. 3 A / max. 600 VA		
Alarm functions:			
Function (switchable):	Steady or fleet (pulse)		
Wash cycle:	0.1 to 199.9 hr		
Wash duration:	1 to 1999 sec		
Pickup delay:	0 to 2000 sec		
Switching voltage/current/power:	Max. 250 VAC / max. 3 A / max. 600 VA		
Electrical data & connections:			
Transmitter function:	0/4 to 20 mA scalable outputs for Conductivity, galvanically isolated		
Hold function switch:	To freeze output current and deactivate control relays		
Load:	Max. 600 Ω		
Conductivity input:	2-pin terminal		
Connection terminal:	5-pole, 17-pole terminal, detachable blocks		
Display:			
LCD:	7 segments display with symbols for status information		
Power supply:			
Input:	110 VAC (jumper selectable); 48 to 62 Hz; max. 7 VA	220 VAC (jumper selectable); 48 to 62 Hz; max. 7 VA	
Main fuse:	Slow-blow 250 V / 100 mA		
Pollution degree:	2		
Transient overvoltage category:	II		
EMC specifications:			
Emitted interference:	According to EN 50081-1		
Immunity to interference:	According to EN 50082-1		
Environmental conditions:			
Operating temperature range:	-10 to 50 $^{\circ}\text{C}$		
Max. relative humidity:	80 % up to 31 $^{\circ}\text{C}$ decreasing linearly to 50 % at 40 $^{\circ}\text{C}$		
Mechanical specifications:			
Dimensions (WxHxD):	96 x 96 x 175 mm		
Weight:	700 g (unit) / 800 g (packed)		
Ingress protection:	IP54 (front panel)		

Conductivity Electrodes

Order Code	ECCS10-0-01T	ECCS10-0-01TS	ECCS10-0-01S	ECCS10-0-01SS	ECCS10-0-1S	ECCS10-0-1SSP	ECCS10-1-0S	ECCS10-1-0SSP
Part No.	93X219019	93X219054	93X219018	93X219053	93X219020	93X219055	93X219021	93X219056
Conductivity Electrodes								
								
Conductivity range	0.055 to 20 µS/cm				0.5 to 200 µS/cm		0.01 to 100 mS/cm	0.01 to 200 mS/cm
Cell constant, K	0.01, 2-cell				0.1, 2-cell		1.0, 2-cell	
Temperature sensor	Pt100, 3-wire							
Pressure rating at 25 °C	3.4 bar (50 psi)	5.5 bar (80 psi)	3.4 bar (50 psi)	5.5 bar (80 psi)	3.4 bar (50 psi)	6.8 bar (100 psi)	3.4 bar (50 psi)	6.8 bar (100 psi)
Operating temperature	-5 to 50 °C / 23 to 122 °F	-5 to 80 °C / 23 to 176 °F	-5 to 50 °C / 23 to 122 °F	-5 to 80 °C / 23 to 176 °F	-5 to 50 °C / 23 to 122 °F	-5 to 150 °C / 23 to 302 °F	-5 to 50 °C / 23 to 122 °F	-5 to 120 °C / 23 to 248 °F
Material	Titanium				SS316			
Fitting material	Nylon plastic	Stainless steel	Nylon plastic	Stainless steel	Nylon plastic	Stainless steel	Nylon plastic	Stainless steel
Thread	½" NPT							
Cable	Integrated 7.5 m (24.6 ft), 6-wire double-shielded, tinned ends							
Dimensions	Length							
	168 mm (excludes cable)							
Weight	Diameter							
	12.8 mm (external)							
Weight	600 g	680 g	680 g	660 g	560 g	660 g	590 g	660 g

Electrode Selection Guide

Conductivity Electrodes	ECCS10-0-01T 93X219019	ECCS10-0-01TS 93X219054	ECCS10-0-01S 93X219018	ECCS10-0-01SS 93X219053	ECCS10-0-1S 93X219020	ECCS10-0-1SSP 93X219055	ECCS10-1-0S 93X219021	ECCS10-1-0SSP 93X219056
General Conductivity measurements	•	•	•	•	•	•	•	•
Low Conductivity measurements	•	•	•	•	•	•	•	•
Conductivity measurements with ATC	•	•	•	•	•	•	•	•
Conductivity measurements of ultrapure water	•	•						
Conductivity measurements of pure water			•	•				
Conductivity measurements of boiler water				•		•		
Conductivity measurements of power plant & condensate water					•	•	•	•

Line Diagram (All dimensions are in mm unless specified otherwise)

Conductivity Electrodes

ECCS10-0-01T
ECCS10-0-01S

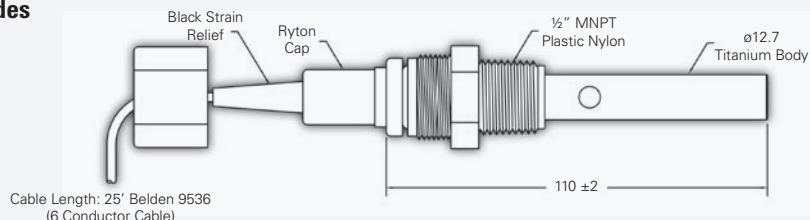

Conductivity Electrodes

ECCS10-0-1S

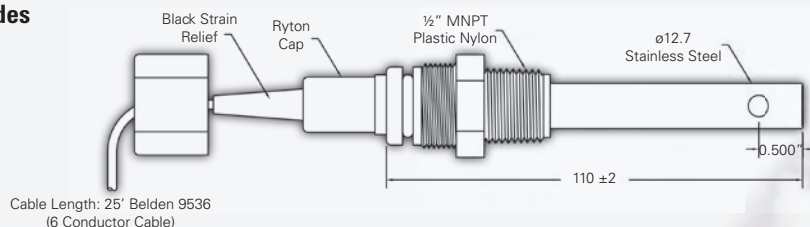

Conductivity Electrodes

ECCS10-1-0S

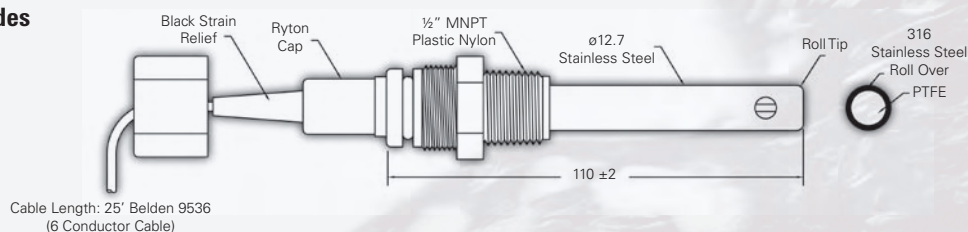

Ordering Information

Order Code	Part Number	Description
TSCONCTP1001	01X216017	Alpha COND 1000 panel-mount Conductivity controller/transmitter with 110 VAC setting. Incl. terminal blocks, gasket, threaded rods, catch, etc
TSCONCTP1002	01X216018	Alpha COND 1000 panel-mount Conductivity controller/transmitter with 220 VAC setting. Incl. terminal blocks, gasket, threaded rods, catch, etc
ECCS10-0-01T	93X219019	Conductivity/Resistivity electrode with Pt100, cell constant K=0.01, titanium with 25 ft tinned open-ended cable (with 1/2 inch nylon plastic cap threading)
ECCS10-0-01TS	93X219054	Conductivity/Resistivity electrode with Pt100, cell constant K=0.01, titanium with 25 ft tinned open-ended cable (with 1/2 inch stainless steel cap threading)
ECCS10-0-01S	93X219018	Conductivity/Resistivity electrode with Pt100, cell constant K=0.01, stainless steel with 25 ft tinned open-ended cable
ECCS10-0-01SS	93X219053	Conductivity/Resistivity electrode with Pt100, cell constant K=0.01, stainless steel with 25 ft tinned open-ended cable
ECCS10-0-1S	93X219020	Conductivity electrode with Pt100, cell constant K=0.1, stainless steel with 25 ft tinned open-ended cable (with 1/2 inch nylon plastic cap threading)
ECCS10-0-1SSP	93X219055	Conductivity electrode with Pt100, cell constant K=0.1, stainless steel with PEEK insert and 25 ft tinned open-ended cable (with 1/2 inch stainless steel cap threading)
ECCS10-1-0S	93X219021	Conductivity electrode with Pt100, cell constant K=1.0, stainless steel with 25 ft tinned open-ended cable (with 1/2 inch nylon plastic cap threading)
ECCS10-1-0SSP	93X219056	Conductivity electrode with Pt100, cell constant K=1.0, stainless steel with PEEK insert and 25 ft tinned open-ended cable (with 1/2 inch stainless steel cap threading)
ECAC021022	81X220803	CPVC electrode tee for Conductivity/Resistivity electrodes with 1/2" to 1" adapter



Thermo Scientific Alpha RES 1000 Resistivity Controller/Transmitter:

Resistivity:

The Alpha RES 1000 offers high accuracy across 2 resistivity ranges with adjustable temperature co-efficient and pure water compensation option. Controller/transmitter is equipped with alarm delay and individual set-point hystereses to prevent chattering, false alarms, and unnecessary down time.

- $\pm 1\%$ full scale accuracy across two Resistivity ranges
- Adjustable temperature coefficient from 0.0 to 10.0 % for higher accuracy
- Pure water compensation option corrects non-linearity of pure water temperature correction curves in ultrapure water applications

















- Option of Auto or Manual Temperature Compensation. Three-wire system compensates for cable-length resistance errors
- Meter displays electrode information after each successful calibration. Previous calibration data is retained in the event of unsuccessful calibrations
- Galvanically-isolated, scaleable 0/4 to 20 mA output for high-quality output on peripheral devices

$\pm 1\%$ full scale accuracy across two resistivity ranges – even in pure water applications

Specification Information

Resistivity Controller/Transmitter		Alpha RES 1000	
Order Code	TSRESCTP1001	TSRESCTP1002	
Part No.	01X216717	01X216718	
Resistivity:			
Range:	0.000 to 1.999 M Ω ; 0.00 to 19.99 M Ω		
Resolution:	0.001 M Ω ; 0.01 M Ω		
Accuracy:	\pm 1 % full scale reading		
Cell constant:	0.1 ; 0.01		
Temperature:			
Range:	-9.9 to 125 °C		
Resolution:	0.1 °C		
Accuracy:	\pm 0.5 °C		
Sensor:	Pt100 / Pt1000 (jumper selectable)		
Compensation:	Auto/manual (normalized at 25 °C)		
Coefficient:	Ultrapure water or linear 0.00 to 10.00 %		
Set point & controller functions:			
Set point 1 (SP1) / set point 2 (SP2):	0.000 to 1.999 M Ω or 0.00 to 19.99 M Ω		
Switching Resistivity hysteresis:	0 to 10 % of full scale		
Function (switchable):	P control (pulse length/pulse frequency); limit control		
Adjustable period with pulse length controller:	0.5 to 20 sec		
Adjustable period with pulse frequency controller:	60 to 120 pulse/min		
Pickup/dropout delay:	0 to 2000 sec		
Contact outputs:	3 SPDT relays		
Switching voltage/current/power:	Max. 250 VAC / max. 3 A / max. 600 VA		
Alarm functions:			
Function (switchable):	Steady or fleet (pulse)		
Wash cycle:	0.1 to 199.9 hr		
Wash duration:	1 to 1999 sec		
Pickup delay:	0 to 2000 sec		
Switching voltage/current/power:	Max. 250 VAC / max. 3 A / max. 600 VA		
Electrical data & connections:			
Transmitter function:	0/4 to 20 mA scalable outputs for Resistivity, galvanically isolated		
Hold function switch:	To freeze output current and deactivate control relays		
Load:	Max. 600 Ω		
Resistivity input:	2-pin terminal		
Connection terminal:	5-pole, 17-pole terminal, detachable blocks		
Display:			
LCD:	7 segments display with symbols for status information		
Power supply:			
Input:	110 VAC (jumper selectable) ; 48 to 62 Hz ; max. 7 VA	220 VAC (jumper selectable) ; 48 to 62 Hz ; max. 7 VA	
Main fuse:	Slow-blow 250 V / 100 mA		
Pollution degree:	2		
Transient overvoltage category:	II		
EMC specifications:			
Emitted interference:	According to EN 50081-1		
Immunity to interference:	According to EN 50082-1		
Environmental conditions:			
Operating temperature range:	-10 to 50 °C		
Max. relative humidity:	80 % up to 31 °C decreasing linearly to 50 % at 40 °C		
Mechanical specifications:			
Dimensions (WxHxD):	96 x 96 x 175 mm		
Weight:	700 g (unit) / 800 g (packed)		
Ingress protection:	IP54 (front panel)		

Resistivity Electrodes

Order Code	ECCS10-0-01T	ECCS10-0-01TS	ECCS10-0-01S	ECCS10-0-01SS	ECCS10-0-1S	ECCS10-0-1SSP	ECCS10-1-0S	ECCS10-1-0SSP
Part No.	93X219019	93X219054	93X219018	93X219053	93X219020	93X219055	93X219021	93X219056
Resistivity Electrodes								
								
Resistivity range	0.55 to 20 $\mu\text{S/cm}$				0.5 to 200 $\mu\text{S/cm}$		0.01 to 100 mS/cm	0.01 to 200 mS/cm
Cell constant, K	0.01, 2-cell				0.1, 2-cell		1.0, 2-cell	
Temperature sensor	Pt100, 3-wire							
Pressure rating at 25 °C	3.4 bar (50 psi)	5.5 bar (80 psi)	3.4 bar (50 psi)	5.5 bar (80 psi)	3.4 bar (50 psi)	6.8 bar (100 psi)	3.4 bar (50 psi)	6.8 bar (100 psi)
Operating temperature	-5 to 50 °C / 23 to 122 °F	-5 to 80 °C / 23 to 176 °F	-5 to 50 °C / 23 to 122 °F	-5 to 80 °C / 23 to 176 °F	-5 to 50 °C / 23 to 122 °F	-5 to 150 °C / 23 to 302 °F	-5 to 50 °C / 23 to 122 °F	-5 to 120 °C / 23 to 248 °F
Material	Titanium				SS316			
Fitting material	Nylon plastic	Stainless steel	Nylon plastic	Stainless steel	Nylon plastic	Stainless steel	Nylon plastic	Stainless steel
Thread	1/2" NPT							
Cable	Integrated 7.5 m (24.6 ft), 6-wire double-shielded, tinned ends							
Dimensions	Length							
	168 mm (excludes cable)							
Weight	Diameter							
	12.8 mm (external)							
Weight	600 g	680 g	680 g	660 g	560 g	660 g	590 g	660 g

Electrode Selection Guide

Resistivity Electrodes	ECCS10-0-01T 93X219019	ECCS10-0-01TS 93X219054	ECCS10-0-01S 93X219018	ECCS10-0-01SS 93X219053	ECCS10-0-1S 93X219020	ECCS10-0-1SSP 93X219055	ECCS10-1-0S 93X219021	ECCS10-1-0SSP 93X219056
General Resistivity measurements	•	•	•	•	•	•	•	•
Low Resistivity measurements	•	•	•	•	•	•	•	•
Resistivity measurements with ATC	•	•	•	•	•	•	•	•
Resistivity measurements of ultrapure water	•	•						
Resistivity measurements of pure water			•	•				
Resistivity measurements of boiler water				•		•		
Resistivity measurements of power plant & condensate water					•	•	•	•

Line Diagram (All dimensions are in mm unless specified otherwise)

Resistivity Electrodes

ECCS10-0-01T
ECCS10-0-01S

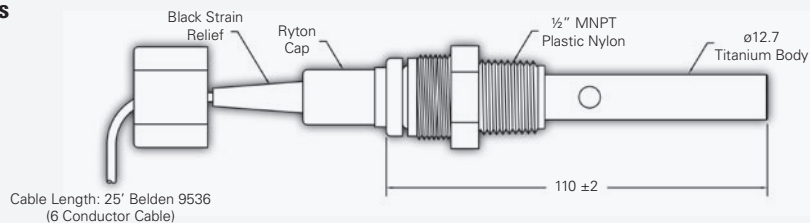

Resistivity Electrodes

ECCS10-0-1S

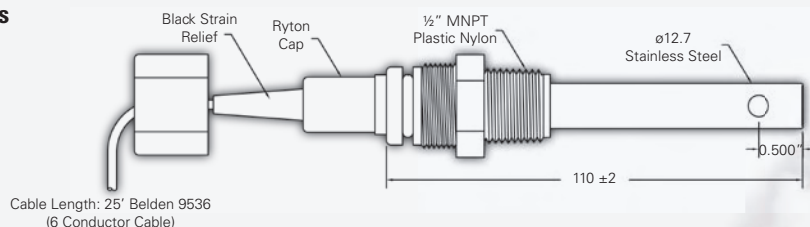

Resistivity Electrodes

ECCS10-1-0S

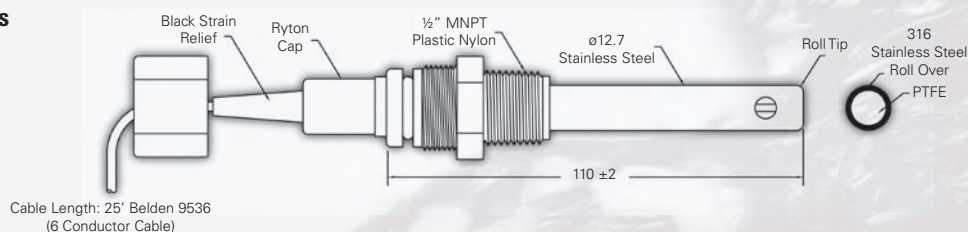

Ordering Information

Order Code	Part Number	Description
TSRESCTP1001	01X216717	Alpha RES 1000 panel-mount Resistivity controller/transmitter with 110 VAC setting. Incl. terminal blocks, gasket, threaded rods, catch, etc
TSRESCTP1002	01X216718	Alpha RES 1000 panel-mount Resistivity controller/transmitter with 220 VAC setting. Incl. terminal blocks, gasket, threaded rods, catch, etc
ECCS10-0-01T	93X219019	Conductivity/Resistivity electrode with Pt100, cell constant K=0.01, titanium with 25 ft tinned open-ended cable (with 1/2 inch nylon plastic cap threading)
ECCS10-0-01TS	93X219054	Conductivity/Resistivity electrode with Pt100, cell constant K=0.01, titanium with 25 ft tinned open-ended cable (with 1/2 inch stainless steel cap threading)
ECCS10-0-01S	93X219018	Conductivity/Resistivity electrode with Pt100, cell constant K=0.01, stainless steel with 25 ft tinned open-ended cable (with 1/2 inch nylon plastic cap threading)
ECCS10-0-01SS	93X219053	Conductivity/Resistivity electrode with Pt100, cell constant K=0.01, stainless steel with 25 ft tinned open-ended cable (with 1/2 inch stainless steel cap threading)
ECCS10-0-1S	93X219020	Conductivity electrode with Pt100, cell constant K=0.1, stainless steel with 25 ft tinned open-ended cable (with 1/2 inch nylon plastic cap threading)
ECCS10-0-1SSP	93X219055	Conductivity electrode with Pt100, cell constant K=0.1, stainless steel with PEEK insert and 25 ft tinned open-ended cable (with 1/2 inch stainless steel cap threading)
ECCS10-1-0S	93X219021	Conductivity electrode with Pt100, cell constant K=1.0, stainless steel with 25 ft tinned open-ended cable (with 1/2 inch nylon plastic cap threading)
ECCS10-1-0SSP	93X219056	Conductivity electrode with Pt100, cell constant K=1.0, stainless steel with PEEK insert and 25 ft tinned open-ended cable (with 1/2 inch stainless steel cap threading)
ECAC021022	81X220803	CPVC electrode tee for Conductivity/Resistivity electrodes with 1/2" to 1" adapter

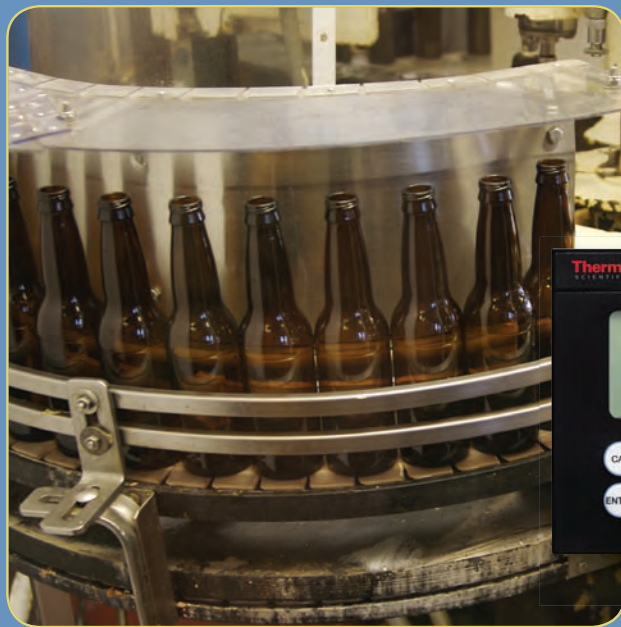

Thermo Scientific Alpha DO 1000 Dissolved Oxygen Controller/Transmitter:

Dissolved Oxygen:

The Alpha DO 1000 controller/transmitter accepts low-range and general range probe for extensive measurement range of Dissolved Oxygen in ppm, mg/L or % saturation. Versatile controller/transmitter offers three Dissolved Oxygen control mode: limit control, proportional pulse length control and proportional pulse frequency control.

- Accepts low range probes (0 to 10 ppm) and general range probes (0.5 to 40 ppm)
- Allows one point or two point DO calibration. Meter displays electrode information after each successful calibration. Previous calibration data is retained in the event unsuccessful calibration



- Automatic salinity and pressure compensation after manual input for more accurate readings
- Option of Auto or Manual Temperature Compensation. Three-wire system compensates for cable-length resistance errors
- Galvanically-isolated, scaleable 0/4 to 20 mA output for high-quality output on peripheral devices

Galvanic operation mode controller requires no 'warm up' time to activate electrode

Specification Information

Dissolved Oxygen Controller/Transmitter		Alpha DO 1000	
Order Code	TSDOCTP1001	TSDOCTP1002	
Part No.	01X242011	01X242012	
Dissolved Oxygen:			
Range:	0.00 to 20.00 mg/L ; 0.0 to 200.0 %		
Resolution:	0.01 mg/L ; 0.10 %		
Accuracy:	±1.5 % of full scale reading		
Temperature:			
Range:	-9.9 to 125.0 °C		
Resolution:	0.1 °C		
Accuracy:	±0.5 °C		
Sensor:	Pt100 ; 3 wire		
Compensation:			
Temperature compensation:	Auto/manual		
Salinity compensation:	0.0 to 50.0 ppt (manual setting and automatic correction)		
Pressure compensation:	kPa/mmHg (manual setting and automatic correction)		
Set point & controller functions:			
Set point 1 (SP1) / set point 2 (SP2):	0.00 to 20.00 mg/L or 0.0 to 200.0 %		
Switching DO hysteresis:	0.1 to 1.0 mg/L or 0 to 10.0 %		
Function (switchable):	P control (pulse length/pulse frequency); limit control		
Adjustable period with pulse length controller:	0.5 to 20 sec		
Adjustable period with pulse frequency controller:	60 to 120 pulse/min		
Pickup/dropout delay:	0 to 2000 sec		
Contact outputs:	3 SPDT relays		
Switching voltage/current/power:	Max. 250 VAC / max. 3 A / max. 600 VA		
Alarm functions:			
Function (switchable):	Steady or fleet (pulse)		
Pickup delay:	0 to 2000 sec		
Switching voltage/current/power:	Max. 250 VAC / max. 3 A / max. 600 VA		
Electrical data & connections:			
Transmitter function:	0/4 to 20 mA scalable outputs for Dissolved Oxygen, galvanically isolated		
Hold function switch:	To freeze output current and deactivate control relays		
Load:	Max. 600 Ω		
DO input:	2-pin terminal		
Connection terminal:	5-pole, 17-pole terminal, detachable blocks		
Display:			
LCD:	7 segments display with symbols for status information		
Power supply:			
Input:	110 VAC (jumper selectable) ; 48 to 62 Hz ; max. 7 VA	220 VAC (jumper selectable) ; 48 to 62 Hz ; max. 7 VA	
Main fuse:	Slow-blow 250 V / 100 mA		
Pollution degree:	2		
Transient overvoltage category:	II		
EMC specifications:			
Emitted interference:	According to EN 50081-1		
Immunity to interference:	According to EN 50082-1		
Environmental conditions:			
Operating temperature range:	-10 to 50 °C		
Max. relative humidity:	80 % up to 31 °C decreasing linearly to 50 % at 40 °C		
Mechanical specifications:			
Dimensions (WxHxD):	96 x 96 x 175 mm		
Weight:	700 g (unit) / 800 g (packed)		
Ingress protection:	IP54 (front panel)		

Dissolved Oxygen Electrodes

Order Code	ECDOGEN-S 01X247507	ECDOTPII-S 01X247508
Part No.		
Dissolved Oxygen Electrodes		
Dissolved Oxygen range	0.50 to 20 ppm	0.03 to 20 ppm
Type	Galvanic	
Flow rate	50 mm/sec (dependent on temperature and O ₂ level)	
Response time	40 to 50 sec to attain 95 % of actual reading	
Temperature sensor	Pt100	
Pressure rating	6 bar (87 psi)	
Operating temperature	0 to 50 °C / 32 to 122 °F	
Material	Delrin housing	
Membrane	HDPE	
Cable	Integral 5 m (16.3 ft) water-resistant, tinned ends	
Dimensions	Length	152.4 mm (excludes cable)
	Diameter	58.4 mm (external)
Weight	670 g	

Electrode Selection Guide

Dissolved Oxygen Electrodes	ECDOGEN-S 01X247507	ECDOTPII-S 01X247508
DO measurements at low levels		•
Waterproof probes	•	•
Galvanic DO measurements system for general purposes, eg. wastewater & aquaculture	•	•
Galvanic DO measurements system for low DO level, eg. power plants, metal corrosion test facilities		•

Line Diagram (All dimensions are in mm unless specified otherwise)

Dissolved Oxygen Electrodes

ECDOGEN-S
ECDOTPII-S

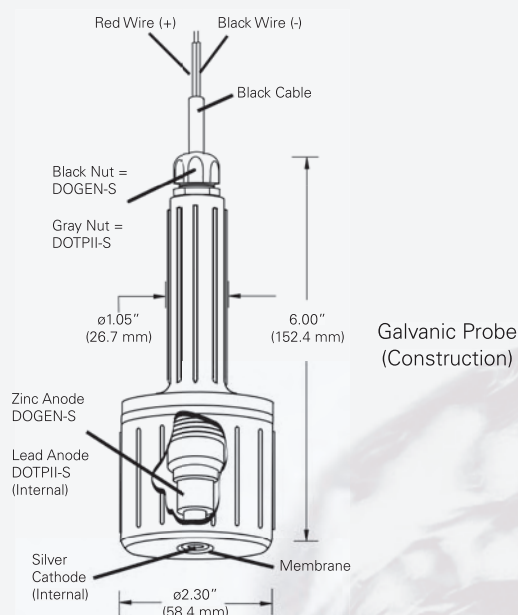
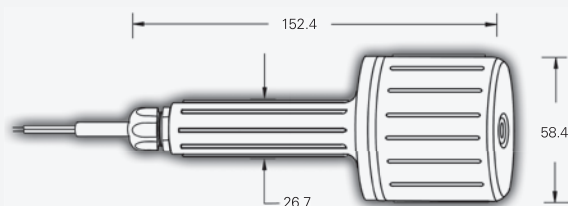

Galvanic Probe (Construction)

Ordering Information

Order Code	Part Number	Description
TSDOCTP1001	01X242011	Alpha DO 1000 panel-mount Dissolved Oxygen controller/transmitter with 110 VAC setting. Incl. terminal blocks, gasket, threaded rods, catch, etc.
TSDOCTP1002	01X242012	Alpha DO 1000 panel-mount Dissolved Oxygen controller/transmitter with 220 VAC setting. Incl. terminal blocks, gasket, threaded rods, catch, etc.
ECDOGEN-S	01X247507	Delrin housing-body galvanic Dissolved Oxygen electrode with Pt100, 5 m tinned open-ended cable
ECDOTPII-S	01X247508	Delrin housing-body, galvanic Dissolved Oxygen electrode with Pt100, 5 m tinned open-ended cable
01X241605	01X241605	Set of 5 o-rings & membranes (DOGEN-S)
01X241606	01X241606	Set of 5 o-rings & membranes (DOTPII-S)
32X246702	32X246702	Large o-ring (DOGEN-S/DOTPII-S)
15X241503	15X241503	Tool for membrane housing (DOGEN-S/DOTPII-S)
ECDOGENSOLNBT	01X211228	DO refilling electrolyte for ECDOGEN-S (480 ml bottle)
ECDOTPIISOLNBT	01X211229	DO refilling electrolyte for ECDOTPII-S (480 ml bottle)

Panel Mount – ¼ DIN (in mm)

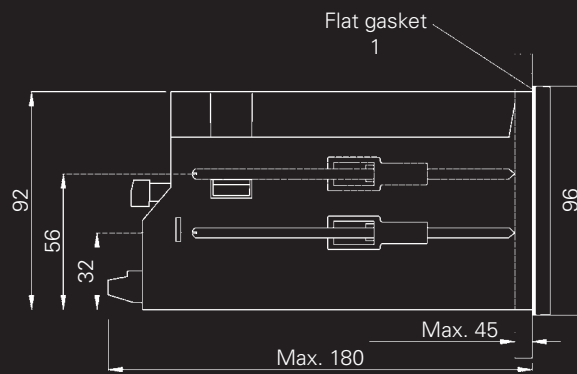
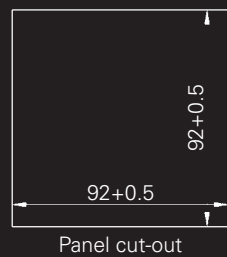

Trademarks Used:

Kynar® is a registered trademark of Arkema Inc.
Ryton® is a registered trademark of Chevron
Phillips Chemical Company LLC.

Warranty:

Thermo Fisher Scientific provides one year of warranty against manufacturing defects for meters, and six months for electrodes.

Disclaimers:

Specifications and terms are subject to change.
Not all products are available in all countries.
Please consult your local sales representative
for details.

All drawings and diagrams are for illustration
purposes only and are not drawn to scale.

About Thermo Fisher Scientific

Thermo Fisher Scientific (NYSE: TMO) is the world leader in serving science, enabling our customers to make the world healthier, cleaner and safer. With annual sales of more than \$9 billion, we employ 30,000 people and serve over 350,000 customers within pharmaceutical and biotech companies, hospitals and clinical diagnostic labs, universities, research institutions, government agencies as well as environmental and industrial process control settings. Serving customers through two premier brands, Thermo Scientific and Fisher Scientific, we help solve analytical challenges from routine testing to complex research and discovery. Thermo Scientific offers customers a complete range of high-end analytical instruments as well as laboratory equipment, software, services, consumables and reagents to enable integrated laboratory workflow solutions. Fisher Scientific provides a complete portfolio of laboratory equipment, chemicals, supplies and services used in healthcare, scientific research, safety and education. Together, we offer the most convenient purchasing options to customers and continuously advance our technologies to accelerate the pace of scientific discovery, enhance value for customers and fuel growth for shareholders and employees alike.



Environmental Instruments

Water Analysis Instruments

North America

166 Cummings Center
Beverly, MA 01915 USA
Toll Free: 1-800-225-1480
Tel: 1-978-232-6000
Dom. Fax: 1-978-232-6015
Int'l Fax: 978-232-6031
www.thermo.com/process

Europe

Denmark House, Angel Drove
Ely, Cambridgeshire
CB7 4ET, UK
Tel: 44-1353-666111
Fax: 44-1353-666001

Asia Pacific

Blk 55, Ayer Rajah Crescent
#04-16/24, Singapore 139949
Tel: 65-6778-6876
Fax: 65-6773-0836



© 2008 Thermo Fisher Scientific Inc.
All rights reserved.

www.thermo.com/process

CON 08X233401 08/08 Rev 1

Thermo
SCIENTIFIC