

Electromagnetic flowmeters

SITRANS F M TRANSMAG 2

Operating Instructions • 12/2010



SITRANS F

SIEMENS

SIEMENS

SITRANS F

Electromagnetic Flowmeters SITRANS F M TRANSMAG 2

Operating Instructions

<u>Introduction</u>	1
<u>Safety notes</u>	2
<u>Description</u>	3
<u>Installing</u>	4
<u>Connecting</u>	5
<u>Commissioning</u>	6
<u>Functions</u>	7
<u>Service and Maintenance</u>	8
<u>Troubleshooting</u>	9
<u>Technical data</u>	10
<u>Parameters</u>	A
<u>Profibus Communication</u>	B
<u>Appendix</u>	C

Legal information

Warning notice system

This manual contains notices you have to observe in order to ensure your personal safety, as well as to prevent damage to property. The notices referring to your personal safety are highlighted in the manual by a safety alert symbol, notices referring only to property damage have no safety alert symbol. These notices shown below are graded according to the degree of danger.

⚠ DANGER
indicates that death or severe personal injury will result if proper precautions are not taken.
⚠ WARNING
indicates that death or severe personal injury may result if proper precautions are not taken.
⚠ CAUTION
with a safety alert symbol, indicates that minor personal injury can result if proper precautions are not taken.
CAUTION
without a safety alert symbol, indicates that property damage can result if proper precautions are not taken.
NOTICE
indicates that an unintended result or situation can occur if the corresponding information is not taken into account.

If more than one degree of danger is present, the warning notice representing the highest degree of danger will be used. A notice warning of injury to persons with a safety alert symbol may also include a warning relating to property damage.

Qualified Personnel

The product/system described in this documentation may be operated only by **personnel qualified** for the specific task in accordance with the relevant documentation for the specific task, in particular its warning notices and safety instructions. Qualified personnel are those who, based on their training and experience, are capable of identifying risks and avoiding potential hazards when working with these products/systems.

Proper use of Siemens products

Note the following:

⚠ WARNING
Siemens products may only be used for the applications described in the catalog and in the relevant technical documentation. If products and components from other manufacturers are used, these must be recommended or approved by Siemens. Proper transport, storage, installation, assembly, commissioning, operation and maintenance are required to ensure that the products operate safely and without any problems. The permissible ambient conditions must be adhered to. The information in the relevant documentation must be observed.

Trademarks

All names identified by ® are registered trademarks of the Siemens AG. The remaining trademarks in this publication may be trademarks whose use by third parties for their own purposes could violate the rights of the owner.

Disclaimer of Liability

We have reviewed the contents of this publication to ensure consistency with the hardware and software described. Since variance cannot be precluded entirely, we cannot guarantee full consistency. However, the information in this publication is reviewed regularly and any necessary corrections are included in subsequent editions.

Table of contents

1	Introduction	5
1.1	Preface	5
1.2	Items supplied	5
1.3	History	5
1.4	Further Information	6
2	Safety notes	7
2.1	General safety instructions	7
2.2	Laws and directives	7
3	Description	9
3.1	Overview	9
3.2	Operating principle	9
3.3	Features	10
3.4	BUS Communication.....	11
4	Installing	13
4.1	General Information	13
4.2	Sensor installation.....	13
4.2.1	Potential equalization of sensor (reference potential)	17
4.3	Turning the local display	18
4.4	Transmitter installation.....	19
4.4.1	Wall mounting with standard mounting plate	19
4.4.2	Pipe or wall mounting with assembly bracket.....	20
5	Connecting	21
5.1	General Information	21
5.2	Step 1: Connecting power supply	23
5.3	Step 2: Connecting signal cables	24
5.4	Step 3: Connecting terminal box and transmitter.....	25
6	Commissioning	29
6.1	Operating TRANSMAG 2.....	29
6.2	Write protection	32
6.3	Language and illumination	33
6.4	Operating examples.....	33
7	Functions	37
7.1	Menu structure	37

7.2	Function Group Display.....	37
7.3	Function Group Diagnostics.....	38
7.4	Function Group Measuring Functions.....	41
7.5	Function Group Device Outputs.....	48
7.6	Function Group Identification.....	55
7.7	Function Group Service.....	57
8	Service and Maintenance.....	61
8.1	Maintenance.....	61
8.2	Cleaning.....	61
8.3	Changing fuses.....	61
8.4	Recalibration.....	62
8.5	Technical support.....	63
8.6	Return procedures.....	64
9	Troubleshooting.....	65
9.1	Quick sensor check-up.....	65
9.2	Application Problems.....	66
9.3	Error messages.....	68
9.4	Application information guide.....	69
10	Technical data.....	73
10.1	Dimensions.....	76
A	Parameters.....	81
B	Profibus Communication.....	93
B.1	PROFIBUS Communication.....	93
B.2	Wiring devices with Profibus PA.....	94
B.3	Cyclic Data Traffic.....	95
B.4	Input Data (from Slave to Master).....	96
B.5	Status bytes.....	97
B.6	Output Data (from Master to Slave).....	100
B.7	Diagnostics.....	100
B.8	Write Protection.....	102
B.9	Device Database File (GSD).....	103
B.10	Literature list.....	107
C	Appendix.....	109
C.1	Certificates.....	109
C.2	Ordering.....	109
	Index.....	111

Introduction

1.1 Preface

These instructions contain all the information you need for using the device.

The instructions are aimed at persons mechanically installing the device, connecting it electronically, configuring the parameters and commissioning it as well as service and maintenance engineers.

Note

It is the responsibility of the customer that the instructions and directions provided in the manual are read, understood and followed by the relevant personnel before installing the device.

1.2 Items supplied

- SITRANS F M TRANSMAG 2
- Wall mounting kit
- Cable glands
- Ferrite cores

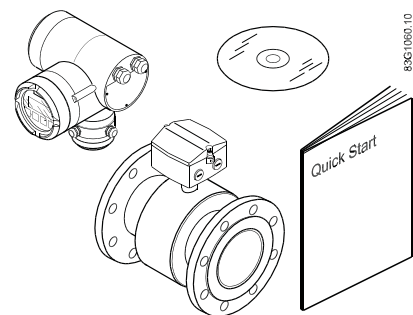

1.3 History

The contents of these instructions are regularly reviewed and corrections are included in subsequent editions. We welcome all suggestions for improvement.

The following table shows the most important changes in the documentation compared to each previous edition.

Edition	Remarks
02/2008	TRANSMAG / Intermag
02/2008	TRANSMAG <ul style="list-style-type: none"> • All information concerning Intermag was removed.
02/2009	TRANSMAG 2 Op. Instr. <ul style="list-style-type: none"> • Restructering of contents.
08/2010	TRANSMAG 2 Op. Instr. <ul style="list-style-type: none"> • Information on the compact version was removed.

1.4 Further Information

The contents of these operating instructions shall not become part of or modify any prior or existing agreement, commitment or legal relationship. All obligations on the part of Siemens AG are contained in the respective sales contract which also contains the complete and solely applicable warranty conditions. Any statements contained herein do not create new warranties or modify the existing warranty.

Product information on the Internet

The Operating Instructions are available on the CD-ROM shipped with the device, and on the Internet on the Siemens homepage, where further information on the range of SITRANS F flowmeters may also be found:

Worldwide contact person

If you need more information or have particular problems not covered sufficiently by the operating instructions, please get in touch with your contact person. You can find contact information for your local contact person on the Internet:

See also

Local contact person (<http://www.automation.siemens.com/partner>)

Product information on the internet (<http://www.siemens.com/flowdocumentation>)

2.1 General safety instructions

 CAUTION
Correct, reliable operation of the product requires proper transport, storage, positioning and assembly as well as careful operation and maintenance. Only qualified personnel should install or operate this instrument.

Note

Alterations to the product, including opening or improper repairs of the product, are not permitted.

If this requirement is not observed, the CE mark and the manufacturer's warranty will expire.

2.2 Laws and directives

General requirements

Installation of the equipment must comply with national regulations.

Instrument safety standards

The device has been tested at the factory, based on the safety requirements. In order to maintain this condition over the expected life of the device the requirements described in these Operating Instructions must be observed.

It generally applies for electrical installation:

- Use heat-resistant cables if high temperatures occur on the housing, e.g. due to heat conductance from the sensor/measuring pipe. Ensure that the cables do not touch the hot sensor tube.

CE-marked equipment

The CE mark symbolizes the compliance of the device with the following guidelines:

- EMC guideline 2004/108/EC
- Low voltage guideline 2006/95/EC
- Pressure equipment directive (PED/DGRL) 97/23/EC

The SITRANS F M magnetic-inductive measuring devices comply with protection class I.

Description

3.1 Overview

SITRANS F M TRANSMAG 2 is a pulsed alternating field magnetic flowmeter where the magnetic field strength is much higher than conventional DC pulsed magnetic flowmeters.

This makes it ideal for difficult applications as:

- High concentrated paper stock > 3 %
- Heavy mining slurries
- Mining slurries with magnetic particles

The complete flowmeter consists of a flow sensor 911/E and the associated SITRANS F M TRANSMAG 2 transmitter.

TRANSMAG 2 is available in a remote version. The 911/E sensor is available with diameters from DN 15 to DN 1000 (½" to 40").

3.2 Operating principle

SITRANS F M TRANSMAG 2 is a microprocessor-based transmitter with a built-in alphanumeric display in several languages. The transmitters evaluate the signals from the associated electromagnetic sensors and also fulfil the task of a power supply unit which provides the magnet coils with a constant current.

The magnetic flux density in the sensor is additionally monitored by reference coils. Further information on connection, mode of operation and installation can be obtained from the sensor data sheets.



Figure 3-1 SITRANS F M TRANSMAG 2 magnetic-inductive flow transmitter

3.3 Features

- Fast signal processing with 16-bit technology
- Automatic recognition of the sensor type and calibration data as result of SmartPLUG. The SmartPLUG is a pre-amplifier in the sensor with integrated data module which contains the stored factory data of the sensor and customer-specific data.
- PROFIBUS-PA (Profile 2.0) or HART communication
- Simple, multi-language menu-guided operation with two-line display and four optical input elements
- Self-monitoring function
- Internal simulation for all input and output functions
- Monitoring of the sensor using magnetizing current and reference voltage as well as wet electrode function
- Analog output and digital outputs for pulses, device status, limits, flow direction, frequency output
- Optional passive switch input for resetting the counter values or for switching off the measuring equipment (PZR)
- With pulsed alternating field for minimum conductivity of 0.1 $\mu\text{S}/\text{cm}$
- Slurry mode
- Parameters can be specifically selected and modified, e.g.:
 - Operating parameters such as measuring range, physical dimensions or device information
 - Limits for flow, counter configurations
 - Noise suppression using separate interference suppression and damping as well as hysteresis functions
 - Automatic mains synchronization
 - Display parameters (freely configurable text display)
 - Display in volume or mass units
 - Density as constant input value for conversion of volume into mass
 - Low flow cut-off
 - Forward and reverse flow measurements
 - Flow direction display and evaluation
 - Diagnostics functions and control values
 - PROFIBUS address
 - Functions of analog output: proportional flow, failure signal
 - Functions of digital output 2 (relay): alarm, forward or reverse flow signal, min. or max. limit for flow and counter
 - Simulation of output signal via analog output, digital output 1 and digital output 2
 - Option: digital output 2 as digital input for resetting counter values or for interruption in measurement (PZR)

3.4 BUS Communication

SITRANS F M TRANSMAG 2 is available with HART or PROFIBUS communication.

- The HART protocol is superimposed on the analog output (current output). This communication capability permits parameterization of the device using the HART communicator or a PC/laptop and SIMATIC PDM software in addition to local operation.
- In the PROFIBUS PA version, the analog output and the digital output 2 are replaced by the digital PROFIBUS PA output. Parameterization of the device is then possible using PROFIBUS communication and SIMATIC PDM in addition to local operation.

Description

3.4 BUS Communication

4.1 General Information

This chapter describes how to install the flowmeter.

CAUTION

The device meets the requirements of IP67 degree of protection. Proper installation is a prerequisite for compliance with this degree of protection. Please observe the instructions in this chapter.

The maximum permissible ambient and medium temperatures must be observed at all times.

The measuring tube should be filled exclusively with media to which the seal and lining materials are chemically resistant. Only conductive media are permissible.

WARNING

If the surface of the sensor or sensor tube can get hotter than 50 °C in the application, fire protection and/or a warning sign must be provided.

4.2 Sensor installation

The measuring principle is generally independent of the flow profile unless static eddy currents penetrate the measured value forming zone (e.g. after pipe elbows, in the case of tangential occlusion or half open slides in front of the sensor). Measures to normalize the flow profile are necessary in such cases. Suitable measures in this respect are:

- increasing the inlet and outlet lines
- using flow rectifiers
- reducing the line cross section

CAUTION

It is recommended to use protective rings (orifice protectors) to protect the inlet and outlet edges of the sensor against mechanical damage especially when used with abrasive media.

Protective rings are available as accessories.

Vertical/horizontal installation

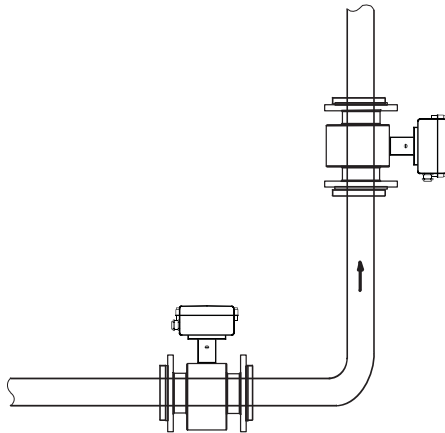

Figure 4-1 Horizontal / vertical installation

Inlet/outlet section

The inlet and outlet lines must be kept straight

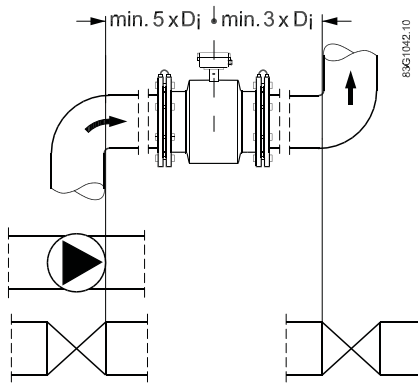

Figure 4-2 Installation between pipe elbows, valves and pumps

Sensor location

Do not install the sensor in pipe sections with a free pipe outlet which could run empty. When installing in a downpipe, make sure that the pipe is always filled 100% with the medium

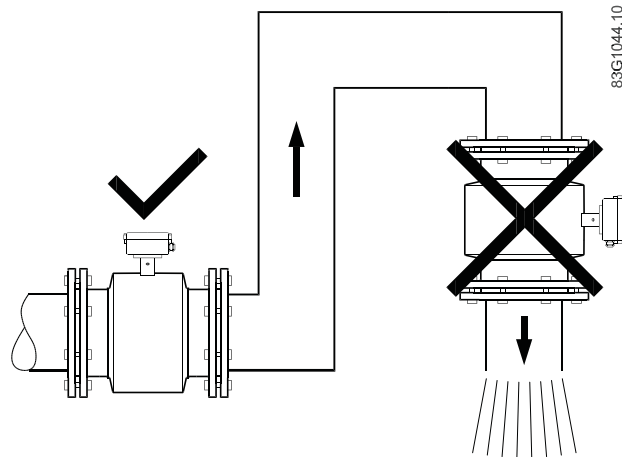

Figure 4-3 Installation in pipes without emptying

Avoid installation at the highest point of the pipe because of accumulation of gas

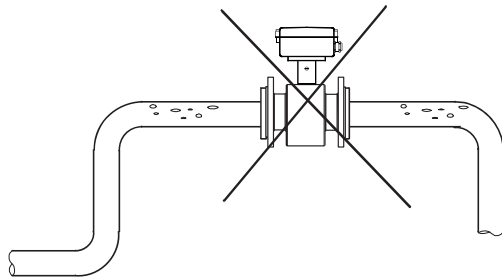

Figure 4-4 Installation at the highest point

Install the flowmeter so that the measuring pipe cannot run empty and is always filled with medium.

The sensor must be installed in a culvert in the case of an unfilled pipe or only a free level line (outlet).

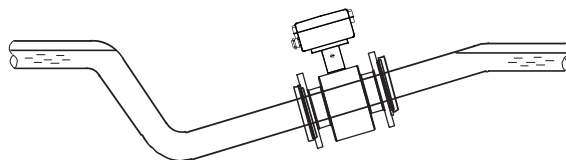

Figure 4-5 Installation in a constantly filled pipe

Line cross sections

By reducing line cross sections you have the possibility of installing smaller sensors in pipes of larger rated widths.

This has the advantage that the speed in the sensor increases with small flows and thus a better measuring accuracy is achieved.

To avoid the formation of eddy currents in the sensor, the angle of reduction should not be greater than 8°.

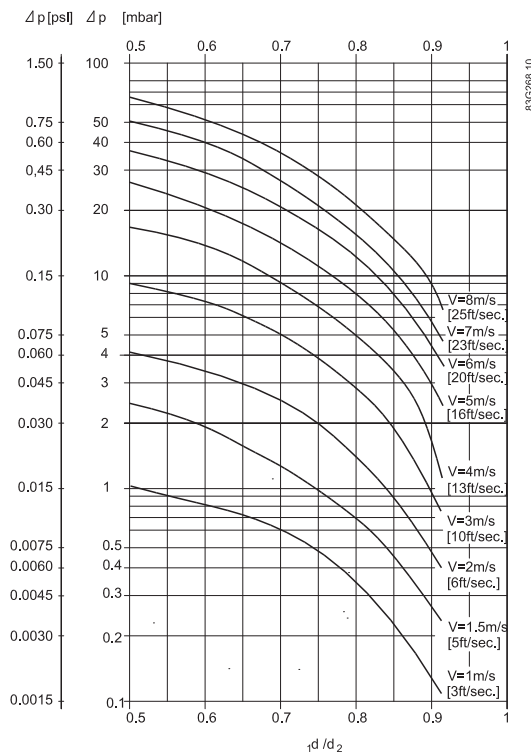
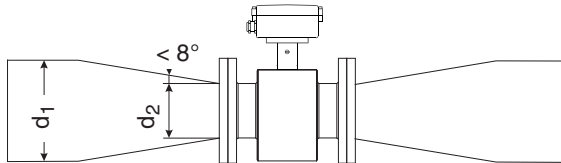

Figure 4-6 Example of reduction of a line cross section

Note

Reductions cause losses in pressure.

4.2.1 Potential equalization of sensor (reference potential)

The sensor must be at the same potential as the medium for an accurate measurement.

This is guaranteed when the connecting flange of the pipe is made of metal and a perfect electrical connection is established to the sensor through the fastening screws. In this case the medium, pipe and transmitter are connected with each other in the sense of a potential equalization.

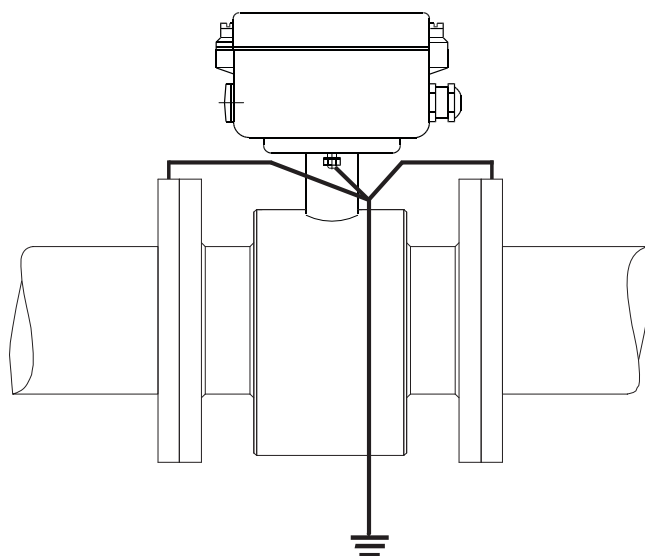

Figure 4-7 Reference potential in electrically conductive pipes

In the case of internally electrically isolated pipes, the medium in the pipe must be applied to a reference potential by additional measures (e.g. by grounding rings). Grounding rings serve to establish the reference potential of the sensor in electrically isolated pipes.

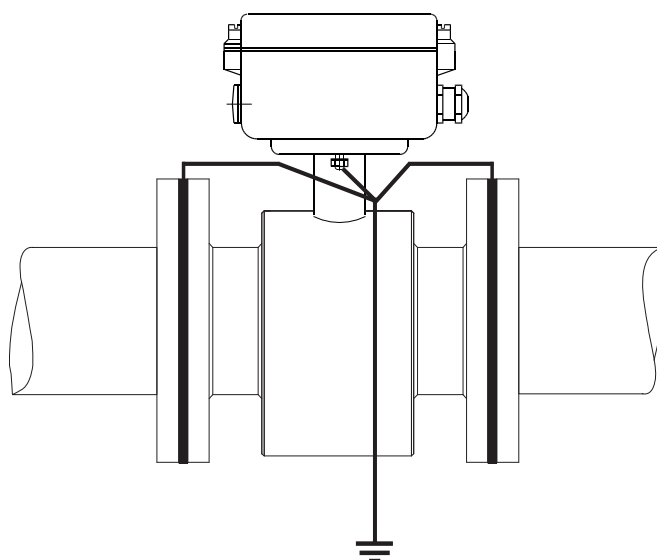

Figure 4-8 Reference potential in electrically isolated pipes by grounding rings

Grounding rings are offered as accessories.

4.3 Turning the local display

The local display can be turned in 90° steps to enable better reading in case of vertical installation or overhead assembly.

1. Switch off the power supply.
2. Release the catch on the lid of the electronics compartment with a 3 mm Allen key.
3. Unscrew the cover.
4. Carefully release the fastening hooks of the local display using a screwdriver or similar tool
5. Pull out the unit, turn it to the desired position and push it back in.
6. Screw the lid back on and mount the lid catch.

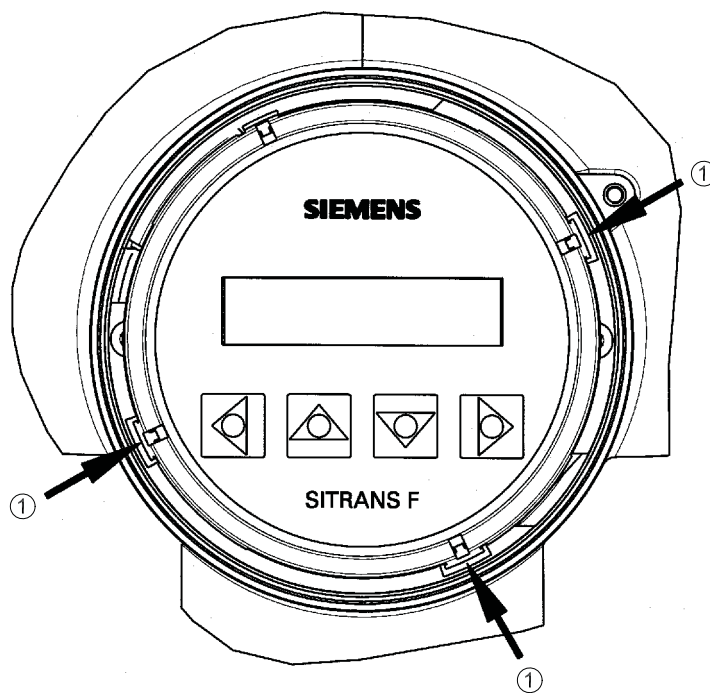

① Fastening hooks

Figure 4-9 Unlocking the fastening hooks on the local display

4.4 Transmitter installation

4.4.1 Wall mounting with standard mounting plate

1. Fit the mounting plate on the transmitter using the mounting material provided
2. Mount transmitter with mounting plate on the wall.

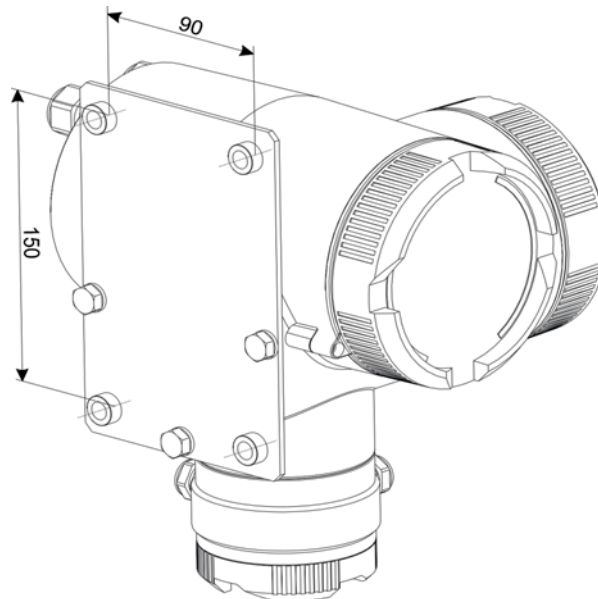

Figure 4-10 Standard mounting plate

Note

The standard mounting plate is only suitable for wall mounting.

4.4.2 Pipe or wall mounting with assembly bracket

Pipe mounting

1. Mount the assembly bracket on the pipe using the fastening brackets
2. Fasten the transmitter with the two screws provided.

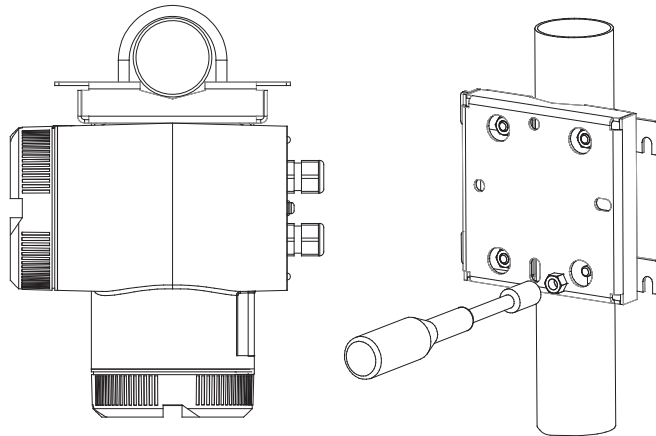

Pipe mounting with assembly bracket

Wall mounting

1. Fasten the assembly bracket to the back of the transmitter
2. Fasten the transmitter and assembly bracket to the wall

Note

The fastening brackets and nuts are not needed for wall mounting.

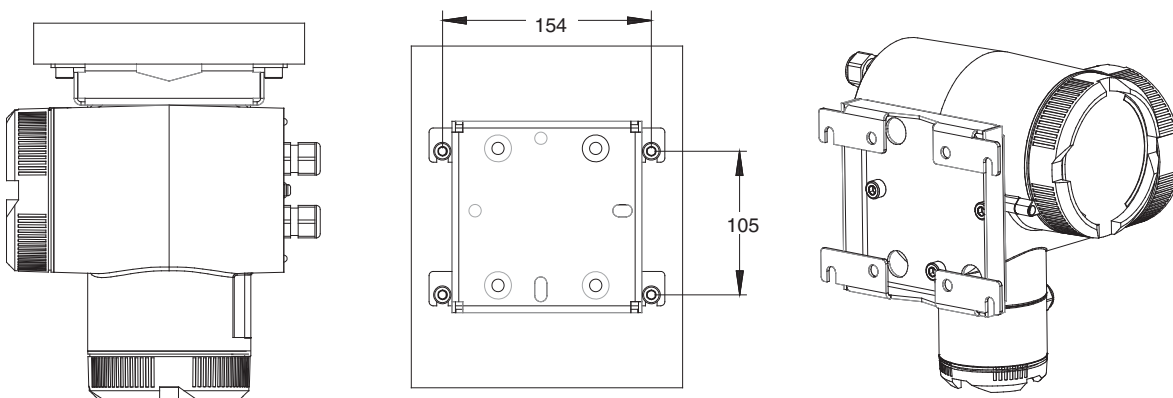

Wall mounting with assembly bracket

5.1 General Information

This chapter describes how to wire up the device.

Step 1 (Connecting power supply (Page 23)), step 2 (Connecting signal cables) and step 3 (Connecting terminal box and transmitter (Page 25)) must always be carried out.

The chapter only describes wiring of devices with HART. In order to wire up devices with Profibus PA, refer to the Appendix:

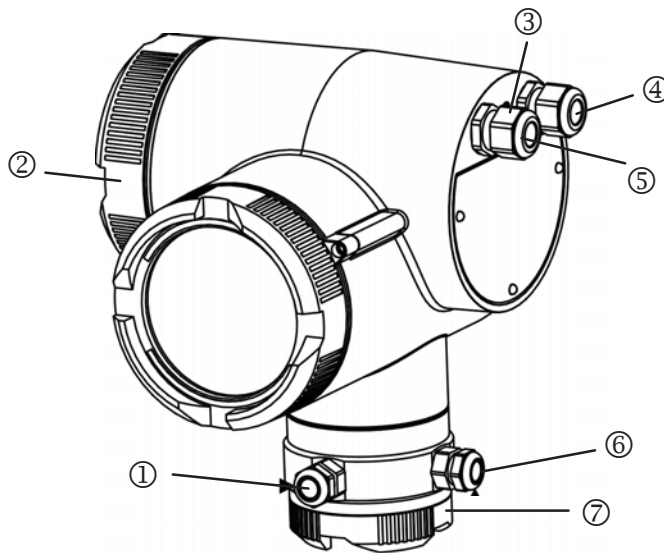

- ① Magnetic current cable
- ② Terminal box for power supply and signal cables
- ③ Potential equalization
- ④ Signal cable
- ⑤ Power supply
- ⑥ Electrode cable
- ⑦ Terminal box for magnetic current and electrode cables

Figure 5-1 Overview, Electrical connections

<p>⚠ WARNING</p> <p>The pertinent regulations must be observed for electrical installation.</p> <p>Never install the device with the mains voltage switched on!</p> <p>Danger of electric shock!</p> <p>The electrodes and magnetic current cables may only be connected when the device is not connected to the power supply.</p> <p>Housing covers may only be unscrewed by qualified personnel when the housing is under voltage (power supply).</p>

Cable specifications

- Only use cables with at least the same degree of protection as the sensor to install the sensor.
- The cable length from the cable gland to the terminals must be kept as short as possible. Cable loops in the terminal box must be avoided.
- To guarantee the IP 67 degree of protection, use cables with the following external diameters:

The permissible external diameter for auxiliary power and signal cable (large terminal box) of the standard device (7ME5034-xxxx-xAA0) is 6 to 12 mm.

Magnetic field current and electrode cable (small terminal box):

- Cable glands M16 x 1.5 6 to 10 mm
- Cable glands 1/2" NPT 5 to 9 mm

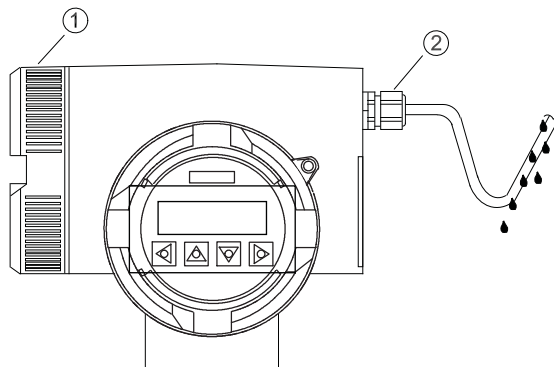

- ① Lid of terminal box
- ② Cable gland

Figure 5-2 Example of lazing cables before connecting the cables

See also

Wiring devices with Profibus PA (Page 94)

5.2 Step 1: Connecting power supply

CAUTION

Only connect the device to the supply which matches the specifications on the rating plate.
Connect the power supply by an easily accessible and appropriately labeled isolating device and fuse (max. 4 A) or an easily accessible circuit breaker (max. 4 A).

Note

Use cables with a cross section of at least 1.5 mm² and double or reinforced insulation for the power supply.

Wiring guidelines

1. Release the catch on the lid of the terminal box using a 3 mm Allen key.
2. Unscrew the lid of the terminal box.
3. Push the supply cable through the cable glands up to the terminal strip. Lay the cable in a loop before the cable glands so that moisture does not get inside the terminal box.
4. Connect the cables according to the figure below.

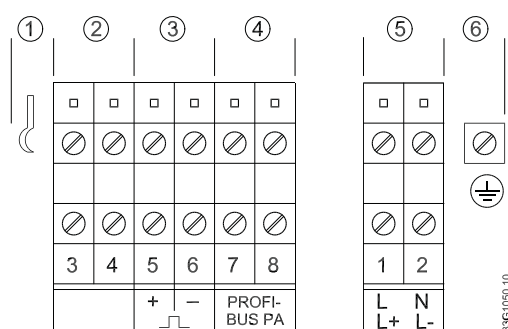

- ① Ground connection for signal cable shield
- ② Digital output 2 (relay) or digital input
- ③ Digital output 1 (active/passive)
- ④ Analog output (active) 4 to 20 mA or PROFIBUS
- ⑤ Power supply: L/N for 100 to 230 V AC
- ⑥ Terminal for PE conductor

Figure 5-3 Connection diagram for power supply and signal cables

5.3 Step 2: Connecting signal cables

 **CAUTION**

Lay the signal cables separately from cables with voltages > 60 V.

Avoid laying signal cables close to large electrical installations or use - if possible - only shielded cables.

Note

In a wet environment, the signal cable for digital output 2 (terminals 3 and 4) must be isolated when the feed-in voltage is more than AC 16V / DC 35 V.

Only use signal cables with twisted wire pairs.

1. Push the signal cable through the cable gland up to the terminal strip. Lay the cable in a loop before the cable glands so that moisture does not get inside the terminal box.
2. Connect the cables according to the figure above.
3. Fit end ferrules to fine-wire cables.
4. Tighten the cable gland and check strain relief.
5. Screw the lid to the housing and tighten it. You must not use any tools. The sealing ring must be clean and undamaged.
6. Mount the lid catch.
7. For transmitters in remote design, also connect the housing to the local potential equalization to which the appropriate sensor must also be connected.

HART requirements

- The full HART 5.1 specification only applies when using shielded cables.
- Use signal cables with twisted wire pairs if the analog output and pulse/frequency output are used simultaneously and signals are transmitted in one cable.
- A load of at least 250 Ω must exist in the signal circuit (see also Technical data) for error free communication via the HART protocol.

5.4 Step 3: Connecting terminal box and transmitter

 **WARNING**

The SITRANS F M TRANSMAG 2 transducer may only be connected to measuring sensor for alternating fields SITRANS F M 911/E.

The magnetic circuit carries dangerous mains voltage.

As long as the device is under voltage, the lid of the housing on the sensor connection area may only be opened by qualified personnel.

Before removing the terminal cover, the auxiliary power must be switched off from all poles.

Following installation, the terminal cover must be screwed back on again.

Connecting

The sensor cable shield is connected to the transmitter and sensor as follows:

1. Bend the cable shield back over the clamping piece of the cable gland.
2. Push the clamping piece with the sensor cable into the threaded bush of the cable gland turning it slightly to the right.
3. Tighten the lock nut on the threaded bushing until the cable is connected tightly (IP67)

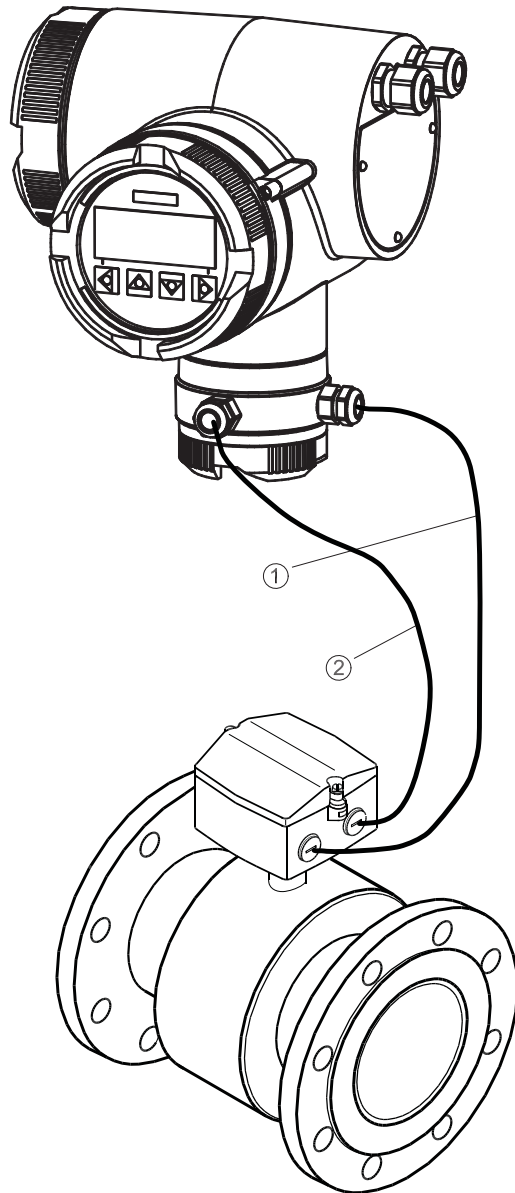

- ① Electrode cable
- ② Magnetic current cable

Figure 5-4 Signal transmission from the sensor to the transmitter

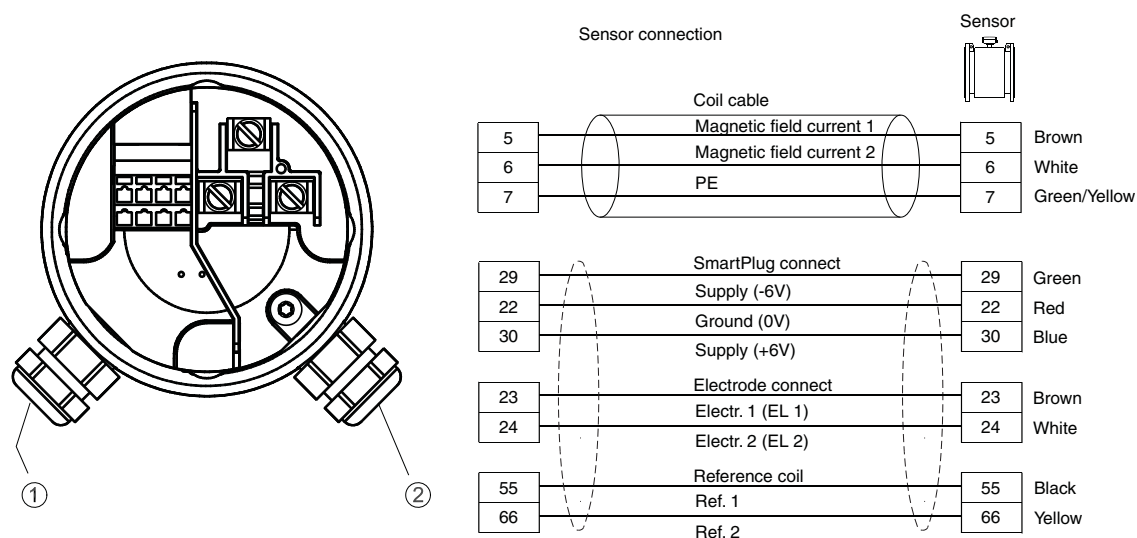

- ① Electrode cable
- ② Magnetic current cable

Figure 5-5 Connection diagram for power supply and signal cables on transmitter

Note

Transmitter and sensor have the same terminal names, the cables must be connected 1:1.

With sensors with IP68 degree of protection, the cable colors or the identification tag on the sensor cables must be observed.

Preparing the cables

Prepare the cable before connection as shown below.

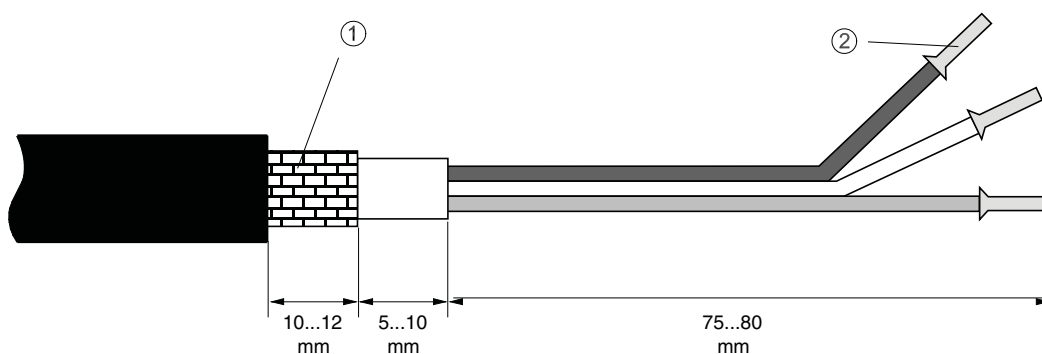

- ① Connector sleeve
- ② Braided screen

Figure 5-6 Preparation of the electrode and magnetic field current cable

5.4 Step 3: Connecting terminal box and transmitter

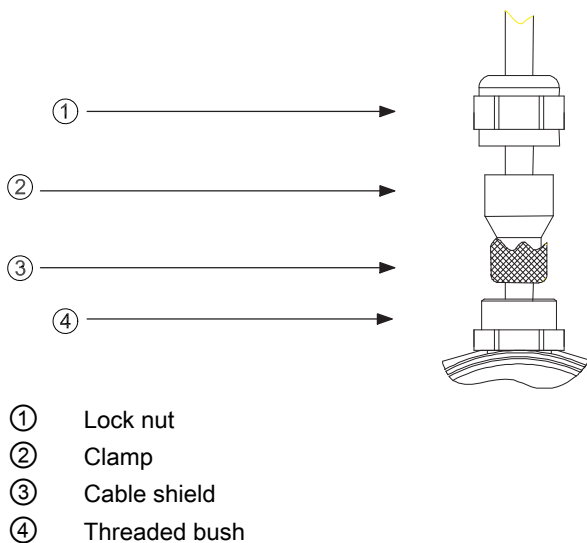

Figure 5-7 Remote connection

Terminal	Designation	Cable color for sensors with IP68 degree of protection	
5	Magnetic field current 1	brown	Magnetic field current cable
6	Magnetic field current	white	
7	Potential equalization/PE	green-yellow	
29	SmartPLUG supply (-5 V)	green	Electrode cable
22	Measuring ground	red	
23	Electrode 1	brown	
24	Electrode 2	white	
30	SmartPLUG-supply (+5 V)	blue	
55	Reference voltage	black	
66	Reference voltage	yellow	

To guarantee the IP67 degree of protection, please use cables with the following external diameters:

- Cable glands M16 x 1.5 6 to 10 mm
- Cable glands M20 x 1.5 6 to 12 mm
- Cable glands 1/2" NPT 5 to 9 mm

The magnetic power cable must be shielded and fitted with a wire gauge of at least 3 x 1.0 mm². For the TRANSMAG 2 (7ME5034), the cable must be of a suitable dimension for the connected mains voltage.

The protective conductor must be marked green-yellow, and must be connected such that it is the last cable to come loose when pulled.

The electrode cable (including the SmartPLUG supply voltage) must also be shielded and should have a wire gauge of 7 x 0.5 mm², (e.g. LIYCY).

 **WARNING**

Certain parts inside the device carry dangerous high voltage. The housing must be closed and grounded before switching the device on.

 **WARNING**

The sensor connected to this device can be operated with high pressure and corrosive media. Therefore improper handling of the device can lead to serious injuries and/or considerable material damage.

Commissioning the device

- Switch on the power supply. The device runs a self-test which lasts about 30 seconds.

If the sensor has a SmartPLUG, the factory data of the sensor as well as essential customer-specific tag data (range, units for flow and totalizers, flow limit values, medium density, operating language) are transferred to the transmitter the first time you switch it on.

The tag data can then be changed permanently in the transmitter. These data are not read in again until a new sensor is connected.

Note

Gas/air in the line

If there is gas/air in the measuring tube or in the pipeline after assembly, a flashing "F" appears at the top of the first line in the display. The flowing medium removes the gas/air occlusions from the tag and the flow can be measured without interference after a few minutes.

6.1 Operating TRANSMAG 2

TRANSMAG 2 can optionally be operated in the following ways:

- via the local display
- via HART or Profibus
- with a PC/laptop and SIMATIC PDM software

Note

The following explains how to operate the device via the local display.

Operation via local display

The device is operated with the optical elements on the local display.

The elements are actuated by touching the glass panel above the appropriate operating element. The text display above the operating elements gives a menu-guided operation of the individual device functions/parameters.

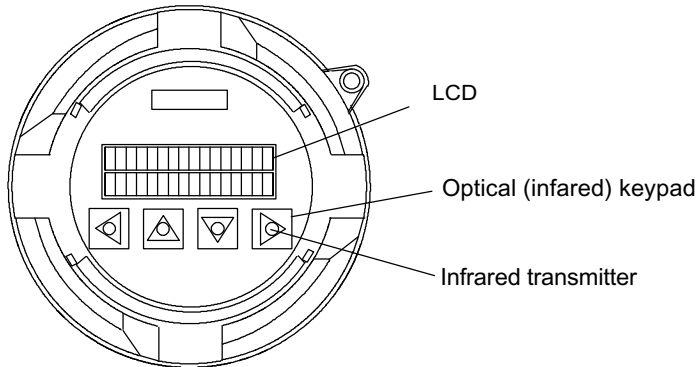





Figure 6-1 Local display of the SITRANS F M TRANSMAG 2

Note





Operation does not require opening of the device. This means that the high degree of protection of IP67 is guaranteed at all times.

Navigating the menu structure



The available device functions and parameters are shown in the second line of the display. You can select them there with the  and  operating elements. You can scroll in the selected device function or setting level of the parameters (Enter function) with . It is possible to exit the selected function or setting level to the level above with .

The currently valid setting appears after selecting the setting level of a parameter. The programmable value flashes in the second line of the display when programming is enabled. You can change the parameter setting in this position. You have to decide between the following types of input to enter data:

- Direct numeric input
- Input from given table

In the numerical input, the  and  operating elements have the function of a cursor control. The selected digit flashes. You can now set the desired digit or move the point to the right or left with the  and  operating elements. Digits are input with carry over to the next highest place. After selecting the last digit you terminate the input by pressing the operating element. The entered value is accepted if it is within the permissible input range. In this case, the user guidance returns to the selection menu for the parameters of the group concerned. If the entered value is rejected, an error message briefly appears on the display and then the previous setting. You can then change it again.

Note

If the  and  operating elements are kept actuated (with your finger continuously on the glass panel) the numeric value or setting option is changed continuously when using the tabular selection. A numeric input carries over to the next highest position.

If you want to prevent an accidentally changed setting from becoming active, you can exit the menu item by pressing the  operating element several times (return to the operating level above).

See also

The exact structure of the operating menu is explained in the appendix Parameters (Page 81) and an overview of the function groups of the menu is offered in chapter: Functions (Page 37).

Operating via BUS communication

The device is integrated into the system as shown below:

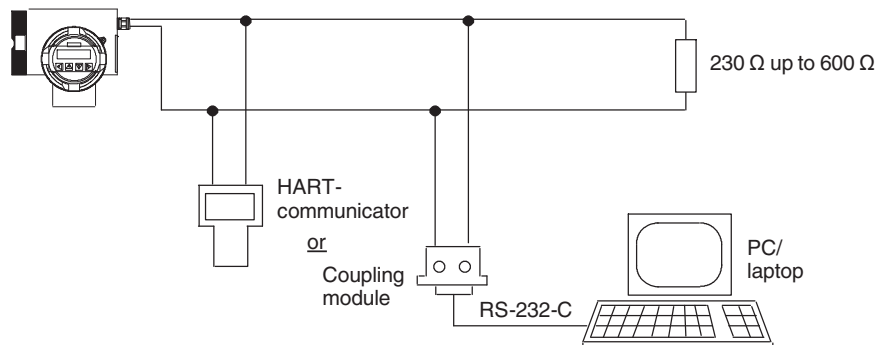

Figure 6-2 System integration via HART

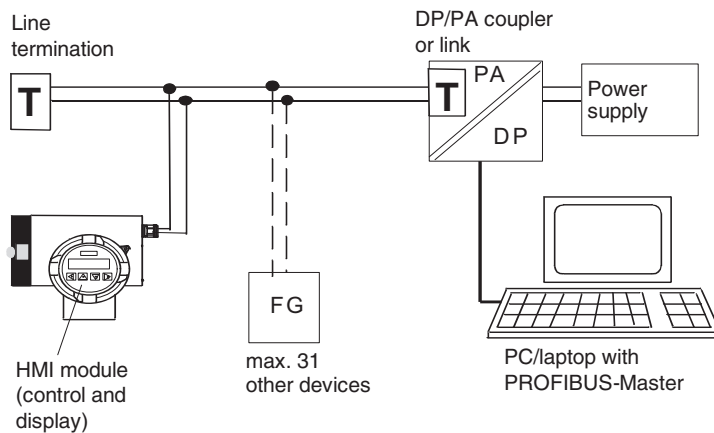

Figure 6-3 System integration via Profibus

System requirements (SIMATIC PDM)

The PC must have the following minimum equipment to operate via SIMATIC PDM:

- Hardware:
 - Pentium processor or higher
 - At least 32 MB RAM
 - Hard disk with at least 110 MB free capacity
 - Monitor: VGA standard or compatible with MS-Windows
 - Keyboard and (optional) mouse
 - CD-ROM drive
 - Interface CP5411 A2 or CP5511 or CP5611
- Software:
 - Windows98, Windows NT4.0 or Windows XP
 - SIMATIC PDM V5.01 or higher (SIMATIC STEP 7 OEM included)



Note

Operation of SIMATIC PDM is supported by integrated help functions.

6.2 Write protection

The local display can be write-protected to prevent unauthorized manipulation by entering a freely selectable, personal code number.

In this case the device functions and parameters can only be changed after entering this code. You define the personal code number in the "6.2 Customer code" menu item.

If you actuate the  and  operating elements in the parameter setting level, the display prompts you to enter the code. You can also enter the code number in the "6.1 Enter Code" menu item. The programming is disabled again:

- after returning to display mode
- about 10 minutes after actuating an operating element
- after entering any number not the same as the code number in the "6.1 Enter Code" menu item

Note

With code = 0 (factory setting), the programming is always enabled.

You can always disable the operation by HART communication.

6.3 Language and illumination

The desired operating language can be set in the control and display unit in menu item "1.1.1 Language".

The background illumination of the LCD is switched on automatically the first time an operating element is actuated. The illumination ceases about 10 minutes after last actuating an operating element. If the display is constantly lit, you can set this using the menu item "1.1.5 Illumination".

6.4 Operating examples

Example 1: Changing engineering unit

In the following example, the engineering unit for the current flow value is changed from m³/h to l/min.

The operating path to be executed is shown semibold in the diagram below. The operating elements to be actuated are specified and the individual operating steps numbered consecutively.

The following display appears after completing the data input (8th operating step)

```
3.1.  Flow
1     Engr. Unit
```

You return to the initial position by actuating the  operating element three times.

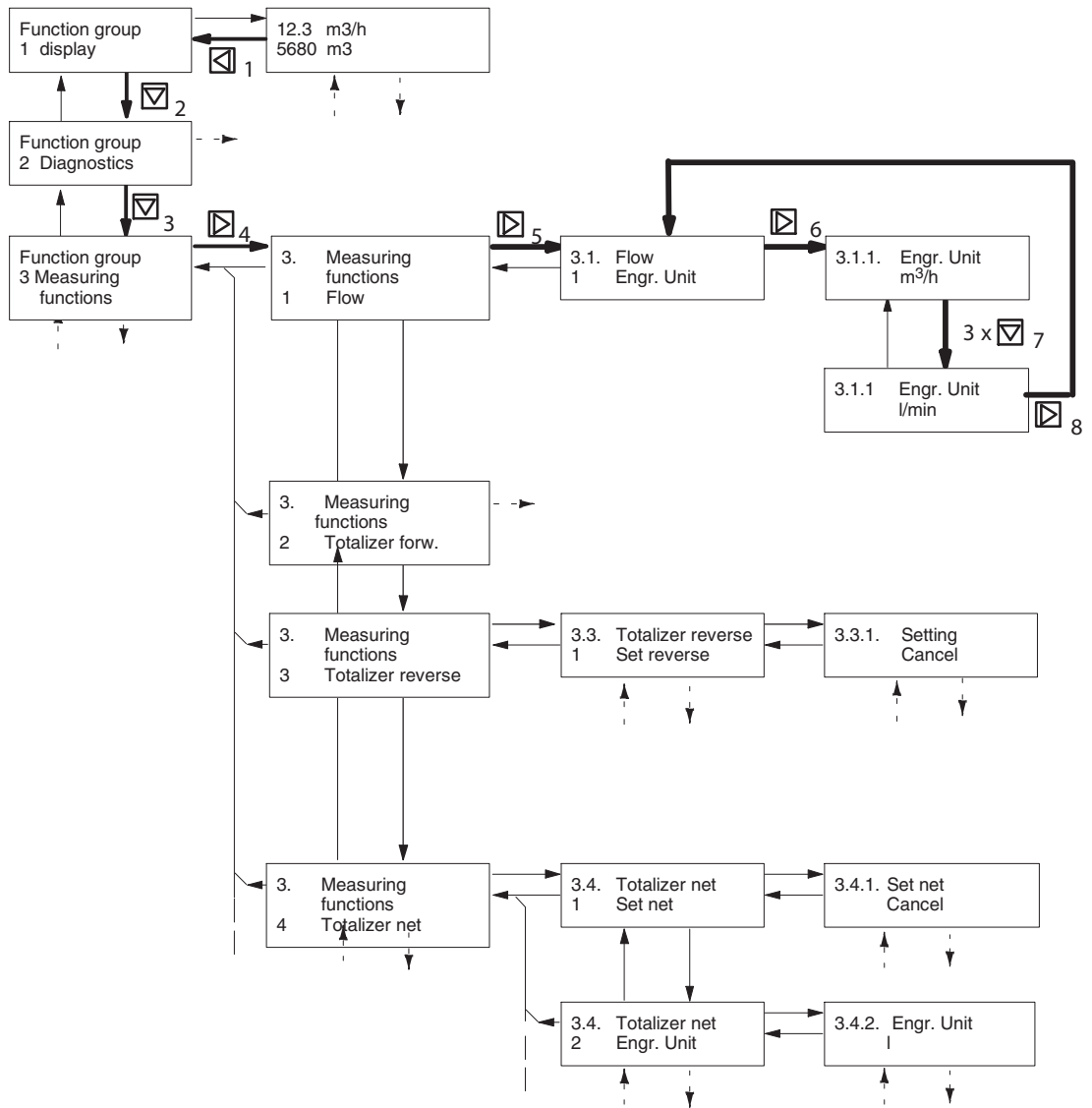

Figure 6-4 Setting current flow unit

Example 2: Changing pulse rate

In the following example the pulse rate is changed from 1 pulse per liter to 200 pulses per liter.

1. Navigate the menu and select menu item 4.2.3 "Pulse rate".

4.2 Digit.output1
3 Pulse rate

Note

See for information on how to navigate the menu.

1. Enable the programming by pressing  once.
The unit in the second display line flashes

4.2.3 Unit
Imp/l

1. Press  once.
Digit 1 flashes

4.2.3 Pulse rate
+1.00 Imp./Unit

1. Change the digit from 1 to 2 by pressing  once

4.2.3 Pulse rate
+2.00 Imp./Unit

1. Select the decimal point by pressing  once

4.2.3 Pulse rate
+2.00 Imp./Unit

1. Move the decimal point two places to the right by pressing the  twice

4.2.3 Pulse rate
+200.00 Imp./Unit

1. Terminate the input by pressing  three times

4.2 Digit.output1
3 Pulse rate

The currently valid setting appears in the display.



Enable the programming.
The unit in the second display line flashes.

Digit 1 flashes.

Change the digit from 1 to 2 with the  operating element

Select the point with the  operating element.

Move the point two places to the right by pressing the  operating element twice.

Select the last position of the number with  and terminate the input by pressing the  operating element (Enter function).

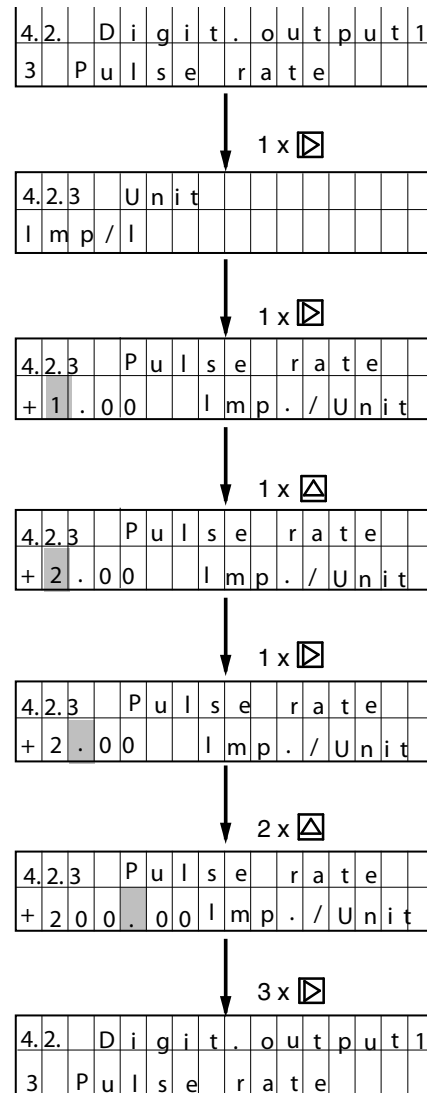

Figure 6-5 Fig_05_06

Functions

7.1 Menu structure

Operation is based on a hierarchically structured operating concept, i.e. all functions/parameters are grouped logically and carry a menu code.

The first (top) level is the main menu. You can select one of the following function groups:

1. Display
2. Diagnosis
3. Measuring functions
4. Device inputs and outputs
5. Identification
6. Service

The individual functions and parameters for further groups are combined under these main groups.

7.2 Function Group Display

The main display (multi display) appears after restarting the transmitter.

Display parameters (Menu item 1.1)

Within the menu you have the following display or setting options:

- Language, menu item 1.1.1
- Line 1, menu item 1.1.2 (definition of measured value)
- Line 2, menu item 1.1.3 (definition of measured value)
- Display of flow value, menu item 1.1.4 (only for line 2)
- Illumination, menu item 1.1.5 (display test)

Multi display (menu item 1.2)

Simultaneous display of two measuring variables

Flow (menu item 1.3)

Display of current flow

Totalizer (menu item 1.4)

Display of total flow

This menu displays all totalizers which can all be reset together.

These are:

- Totalizer forwards, menu item 1.4.1
- Totalizer reverse, menu item 1.4.2
- Totalizer net, menu item 1.4.3
- Set (all), menu item 1.4.4

Note

The totalizers show the total flow volume since starting the measurement. Use the menu items 3.2, 3.3 and 3.4 for separate setting and resetting of the units. The totalizer is restarted when it overruns.

Note

The value range of the totalizers in PROFIBUS and HART communication is principally - 10^{38} m³ to + 10^{38} m³. However, since the value range of the local display is limited to 999 999 999, the display stays at 999 999 999 when this range is exceeded, while totalizing continues internally.

Flow velocity (menu item 1.5)

Display of current measured value in m/s

Frequency (menu item 1.6)

Display of current measured value in Hz

Analog Out1,2 (menu item 1.7)

Display of current measured value in mA

7.3 Function Group Diagnostics

Device status (Menu item 2.1)

During normal operation, test routines are run continuously.

The display "OK" appears in the case of error-free operation after selecting menu item 2.1 (device status). An error message is displayed in clear text in the event of an error.

The possible error messages are listed in the table below and the assignment of the error messages to the individual outputs specified. The error message can only be output via the digital outputs 1 and 2 and the analog output if configured accordingly (selection of 'Alarm' function for the digital outputs or 'Failure signal' for the analog output) (see menu items 4.1.2, 4.2.1 and 4.3.1).





- A flashing "F" process related error at the top right of the display indicates a process error.
- A flashing "D" at the top right of the display indicates a device error.

Should errors in groups 'F' and 'D' occur at the same time, only 'D' will flash.

In communication via PROFIBUS, the diagnostic message displayed here is also reported under the extended diagnosis with the diagnostic bit "EXTENSION_AVAILABLE".

Table 7- 1 Error messages

Error message	Flashing indication in display menu	Error is Signaled at the analog output	Error is signaled at digital output 1 and 2	PROFIBUS
Measurement module failure	F	-	-	x
Calibration failure measurement module	F	-	-	x
Simulation is running	F	-	-	x
Flow measurement unreliable	F	-	-	x
Calibration is running	F	x	x	x
Tube empty	F	x	x	x
Measuring range overflow > 110 %	F	x	x	x
COM Module failure	D	-	-	-
Memory failure	D	x	x	x
Software failure	D	x	x	x
Sensor failure	D	x	x	x
Flow measurement disturbed	D	x	x	x

For texts with more than 16 characters, the marks  and  in the first and last segment of the device display respectively indicate that there are other characters to the left and/or right of the displayed text. You can display these by actuating the  and  operating elements.

Electrode check (Menu item 2.2)

The electrode DC voltage is scanned cyclically when this menu item has been selected. This detects e.g. deposits on the electrodes. If there is a fault or an error, the alarm signal 'Flow measurement unreliable' is triggered.

Note

This function requires a sensor with SmartPLUG.

Empty Pipe Det. (menu item 2.3)

The function checks whether the electrodes of the sensor are wetted by the medium. To do this, you have to determine the monitoring interval.

If the electrodes have no contact with the medium, the alarm signal "Tube empty" is triggered through the digital outputs. This alarm is also triggered in the case of an insulating coating on the electrodes.

 WARNING
--

This message does not mean that the tube has actually run empty. Therefore you must make sure that the pipeline is actually empty before your remove the tube!
--

Note

Response threshold and timing behavior of the "immersion check" function depend on the conductivity of the medium and the nominal width and cladding of the sensor (min 50µS/cm). The switching threshold can be adapted to these conditions, if necessary (see menu item 6.7.5).

Device test (Menu item 2.4)

The device test comprises the following test components:

- Self test, menu item 2.4.1

The self test routines are inserted in the current measurements and are completed after about 60 seconds. If there is no error, "OK" is displayed, otherwise "not OK". The type of error can then be read out in the menu item "2.1 Device status".

- Display test, menu item 2.4.2

The LCD is checked with this menu item. The display is initially dark for approx. 5 seconds and then bright for approx. 5 seconds.

Simulation flow (Menu item 2.5.1)

The flow can be simulated in a range from $\pm 110\%$.

Here you also have the possibility of checking displays, totalizers, limit values and outputs in certain measuring ranges. The running simulation is indicated by a flashing 'F'. It ends at the end of a previously set period or after entering the 'End' parameter in this menu item.

Simulation outputs (Menu item 2.5.2, 2.5.3, 2.5.4)

With this function you can check the signal circuits of the analog output, the digital outputs 1 and 2 as well as the flow.

In the individual menu items, you select the value to be simulated with the and operating elements. You activate the setting by confirming the selected value with the operating element . The running simulation is indicated by a flashing 'F'. You end simulation of the output signal by actuating the operating element (exit the menu item).

Digital output 1 must be configured for the "Alarm" function for simulation of the alarm signal (setting in the menu item "4.2.1 Function").

7.4 Function Group Measuring Functions

Flow (Menu item 3.1)

You have the following setting options in this menu:

- **Engineering unit**, menu item 3.1.1
This function offers you the possibility of choosing between units of volume flow (volume unit per time unit) or mass flow (mass unit per time). If a unit of mass is selected, it is mandatory to enter the density of the medium in menu item 3.1.4.
- **Flow Upper Range Value (URV)**, menu item 3.1.2
The full scale value is set depending on the nominal width of the sensor and the valid speed range (0.25 - 12 m/s). The start of scale value is always 0 (zero).

Note

Devices with PROFIBUS PA

Although the profile parameter for the start of scale value (0%) can always be written by acyclic communication, values not equal to 0 are rejected.

The output scale does not appear in the local operating unit. It is always automatically set to be identical with measuring scale, i.e. the profile parameters start / end of the output scale are automatically set to 0 or "URV". Other values are rejected in acyclic PROFIBUS communication.

The set URV only has an influence on the percentage defined values such as "flow in %", hysteresis and the digital output 1.

Measured values outside this range are also reported by PROFIBUS as valid measured values providing they are within the sensor limits. The sensor limits for flow depend on the nominal width and correspond to a flow velocity range of about -13 m/s to +13 m/s.

Measured values outside the sensor limits are displayed but are no longer within the specified range; "uncertain, nonspecific, low limited" or "uncertain, nonspecific, high limited" is then reported as a measured value status.

- **Limits**, menu item 3.1.3, consisting of:
 - Low Alarm Limit, menu item 3.1.3.1 and
 - High Alarm Limit, menu item 3.1.3.2

The input is made in absolute values within the sensor limits (depending on the nominal width, corresponding to -13 m/s to +13 m/s). Alarm limits of min. 10% and max. 90% of the URV are set at the factory.

Exceeding or dropping below these limit values are signaled at digital output 1 or 2 if the function of these outputs is configured appropriately (menu items 4.2.1 and 4.3.1). In PROFIBUS communication, these events are reported by the limit bits in the measured value status.

Note

Devices with PROFIBUS PA

The profile parameters for the "Low Warning Limit" and "High Warning Limit", can be set independently of the alarm limits by acyclic PROFIBUS communication. They do not appear in the local operating unit. Exceeding of the warning limits is only signaled by PROFIBUS communication.

- **Hysteresis**, menu item 3.1.3.3

The limit values (menu items 3.1.3.1 and 3.1.3.2) can have a hysteresis added to prevent "fluttering" of the switching output.

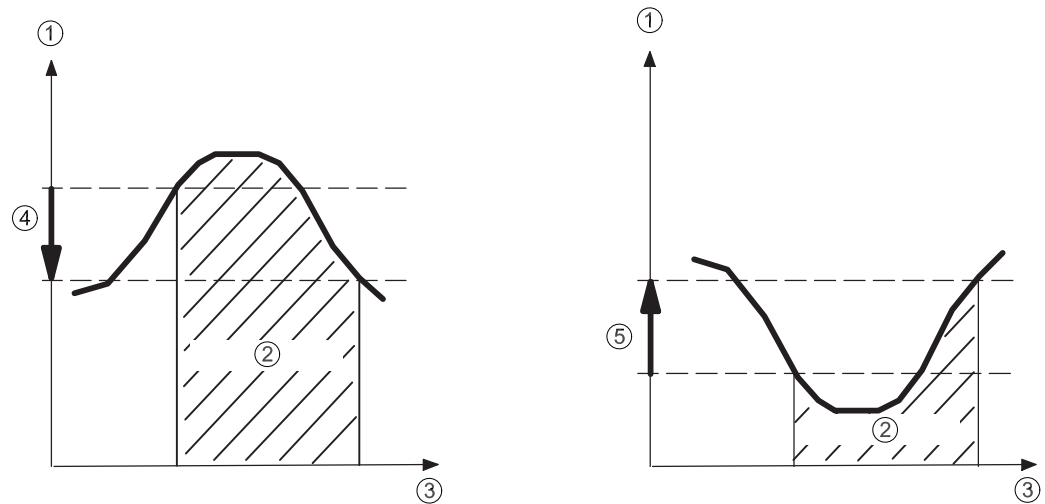

- ① Measured variable
- ② Limit alarm
- ③ Time
- ④ Hysteresis - limit max.
- ⑤ Hysteresis - limit min.

Figure 7-1 Limit value message and hysteresis

- **Density**, menu item 3.1.4
 You must specify unit and density here. The volume flow q_v is converted to mass flow q_m automatically using the formula ($q_m = q_v \cdot \rho$).
 - **Direction**, menu item 3.1.5.
 This item is divided into:
 - **Flow direction**, menu item 3.1.5.1
 - **Measuring direction**, Menu item 3.1.5.2
 - **Hysteresis**, Menu item 3.1.5.3
1. The flow direction (3.1.5.1) is preset at the factory and indicated by the arrow on the sensor. If the flow direction does not match the direction of the arrow it must be adapted in this menu item.

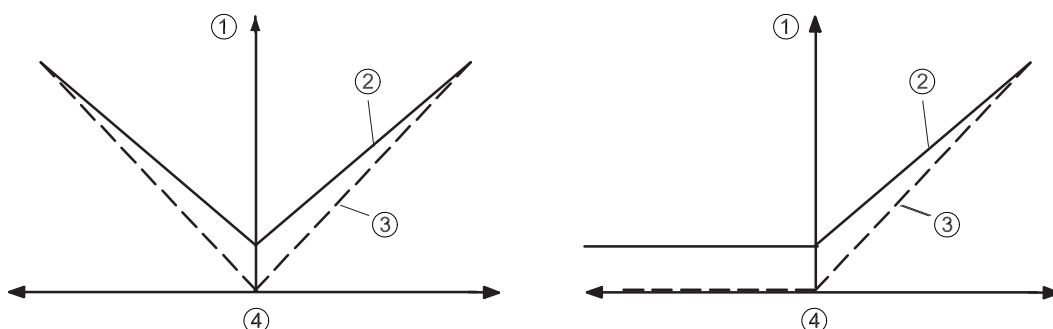
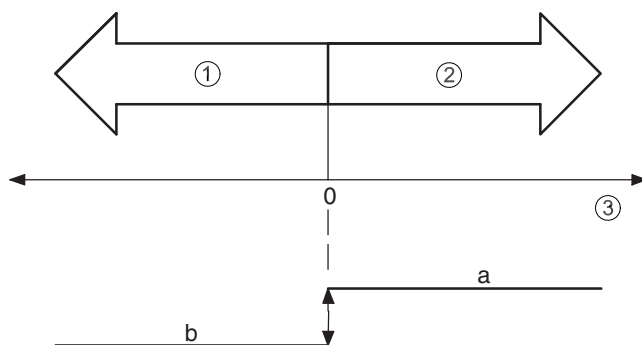

Figure 7-2 Setting Forw. and Rev. (left) and setting Forw. only (right)

2. With measuring direction (3.1.5.2) it is possible to detect flow in forward and backward direction and to pass on the appropriate signal proportionally to the analog or digital output. In "forwards" parameterization, only signals in this direction are output or accumulated internally.

Example 1: Hysteresis = 0%



Example 2: Hysteresis = 0%

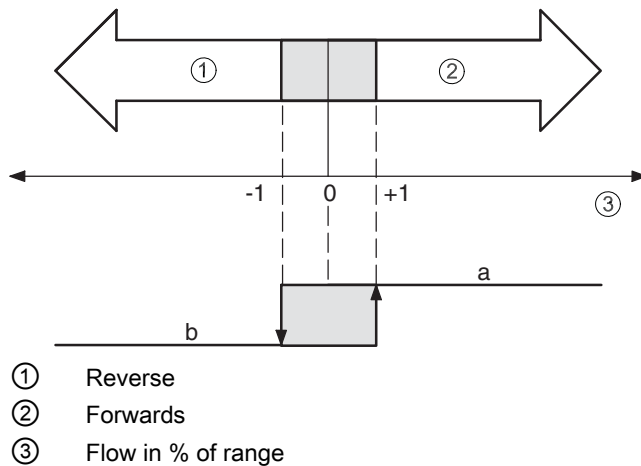

Figure 7-3 Hysteresis flow direction

1. Hysteresis (3.1.5.3). The limit values (menu items 3.1.5.1 and 3.1.5.2) can have a hysteresis added to prevent "fluttering" of the switching output. This setting is made in % of the set full scale value in the menu item 3.1.5.3 "Hysteresis". If, for example, the hysteresis is 1 %, the relay contact does not switch until a flow of -1% of the full scale value and returns to the original position at a flow of +1% of the full scale value.

Table 7-2 Switching status of the relay for selected signal type

- Contact closes:	a →	Relay contact closed
	b →	Relay contact open
- Contact opens:	a →	Relay contact open
	b →	Relay contact closed

- **Low flow cut**, menu item 3.1.6

This parameter determines the switching point for low flow cut-off. The low flow cut prevents flow being measured in the lower range (e.g. fluctuating liquid columns at a standstill). The low flow cut-off affects: display, totalizers, analog output and pulse frequency output as well as HART and PROFIBUS communication.

- In devices with HART communication, the value of the low flow is related percentage-wise to the upper range value (menu item 3.1.2).
- In devices with PROFIBUS communication, the absolute value must be entered in the selected unit of flow (menu item 3.1.1).

- **Filter time constant**, menu item 3.1.7.1

The jump response can be suppressed in this menu item. This may be necessary depending on the application, for example in the case of fast changing flows to keep the display value or analog value stable.

- **Noise Suppress**, menu item 3.1.7.3

This function serves to eliminate temporary, application-related interference within a fixed time frame.

Every measured value within a measuring pulse is compared with the previously determined value. If it is outside the tolerance band set under menu item 3.1.7.3 (the specified % value refers to the set full scale value), the device operates with a filter time constant of 10 s.

This applies for the suppress time set in menu item 3.1.7.3. If a greater deviation occurs during this time, the time starts again from the beginning. If a disturbed signal is applied continuously, the device remains set to the greater filter time constant until the un-attenuated measured values are back within the selected tolerance band. The device switches back to normal mode at the end of time "t" after the last detected deviation.

- **Slurry mode**, menu item 3.1.8

For media with high solids content, magnetically conductive solids or air locks, the stability of the measured values can be significantly improved with this setting, while the reaction speed remains the same when the flow is altered.

If necessary, the stability of the measured value can be further increased using the "Filter time constant" (menu item 3.1.7.1) or "Error blanking" functions, although this will in turn reduce the measuring dynamics.

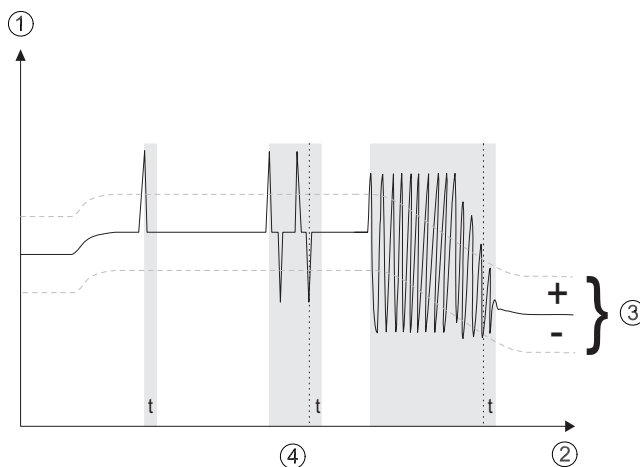

- ① Un-attenuated measuring variable
- ② Time
- ③ Tolerance band
- ④ t = suppress time



- ① Flow in % with filter time constant
- ② Time

Effect of a noise signal filter (example)

Total. forwards (Menu item 3.2)

You have the following setting options in this menu:

- **Set**, menu item 3.2.1

In this menu you can reset the forwards totalizer to zero and restart if necessary.

If the totalizer overruns the optical display of the totalizer stops at "999999999" but the device continues counting internally. You have to set a greater unit to be able to read the current totalizer reading again.

You have the following individual setting options:

- Reset+Stop: the totalizer is set to 0 and held.
- Reset+Start: the totalizer is set to 0 and restarted 1,2
- Totalize: the totalizer is started 3

- **Unit**, menu item 3.2.2

With this function you can select physical units or switch from one unit to another. In the latter case the device converts the previous totalizer reading into the new unit.

- **Alarm limit**, menu item 3.2.3

Here you can set all values from 0 to +108. You can assign reaching or exceeding this limit value as a signal to a digital output.

Total. reverse (Menu item 3.3)

You have the following setting options in this menu:

- **Set**, menu item 3.3.1

In this menu you can reset the reverse totalizer to zero and restart if necessary.

If the totalizer overruns the optical display of the totalizer stops at "999999999" but the device continues counting internally. You have to set a greater unit to be able to read the current totalizer reading again.

You have the following individual setting options:

- Reset+Stop: the totalizer is set to 0 and held.
- Reset+Start: the totalizer is set to 0 and restarted 1,2
- Totalize: the totalizer is started 3

- **Unit**, menu item 3.3.2

With this function you can select physical units or switch from one unit to another. In the latter case the device converts the previous totalizer reading into the new unit.

- **Alarm limit**, menu item 3.3.3

Here you can set all values from 0 to -108. You can assign reaching or exceeding this limit value as a signal to a digital output.

Totalizer net (Menu item 3.4)

You have the following setting options in this menu:

- **Set**, menu item 3.4.1

In this menu you can reset the totalizer net to zero and restart if necessary.

The net totalizer forms the difference (error sum) between forward and backward flow.

If the totalizer overruns the optical display of the totalizer stops at "999999999" but the device continues counting internally. You have to set a greater unit to be able to read the current totalizer reading again.

You have the following individual setting options:

- Reset+Stop: the totalizer is set to 0 and held.
- Reset+Start: the totalizer is set to 0 and restarted 1,2
- Totalize: the totalizer is started 3

- **Unit**, menu item 3.4.2

With this function you can select physical units or switch from one unit to another. In the latter case the device converts the previous totalizer reading into the new unit.

- **Low Alarm Limit value**, menu item 3.4.3

Here you can set all values from -1 to -109. You can assign reaching or exceeding this limit value as a signal to a digital output.

- **High Alarm Limit**, menu item 3.4.4

Here you can set all values from 1 to +109. You can assign reaching or exceeding this limit value as a signal to a digital output.

- **Hysteresis**, menu item 3.4.5

The limit values (menu items 3.4.3 and 3.4.4) can have a hysteresis added to prevent "fluttering" of the switching output.

7.5 Function Group Device Outputs

Analog out (Menu item 4.1)

This menu only appears in devices with a 20 mA output (7ME5034-0xxxx and -2xxxx).

The following settings are possible:

- **Current limiting**, menu item 4.1.1

The upper current limit for the output signal is determined in this menu item.

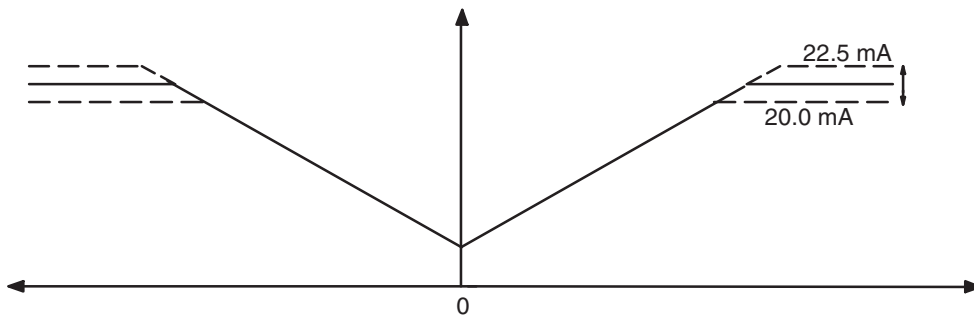

- ① Current
- ② Parameter range
- ③ Measured value

Figure 7-4 Current limiting

- **Failure signal**, menu item 4.1.2

In the event of a fault, e.g. a device error or measuring error due to entrapment of air, the analog output shows a predefined current.

The following settings are possible:

- 3.6 mA
- 22 mA
- 24 mA
- Hold for a defined time (5...240 seconds), then 3.6 mA
- Hold permanently

With the "Hold 5 s" setting you can bypass temporary faults (e.g. air entrapment in the medium) for up to about 5 s without the analog signal outputting an error message. The same applies accordingly for "Hold 20 s", "Hold 40 s" etc. The last valid measured value is output during the fault. If the fault lasts less than 5 s the current measured value is output at the end of the fault. If the fault persists, the output signal is set to 3.6 mA.

In the "Hold permanently" setting the last valid value is output until the fault is eliminated.

In the current range between 0 and 20 mA, the 3.6 mA failure signal or "Stop" is not recommended; in this case, the setting '22 mA' or '24 mA' must be selected.

- **Split mode** (combined counter), menu item 4.1.4

The Split mode is activated when 'Active' is selected.

The "Split value" divides the measuring range (URV) set in menu item 3.1.2. The split value is only effective when it is smaller than the full-scale value (upper range value, URV).

When Split mode is activated, if there is a current flow value in the lower sub-domain (0 to split value), this sub-domain is shown in a linear way on the set current range (0-20 mA or 4-20 mA), i.e. a current of 20 mA corresponds to the split value. This status can be indicated on digital outputs 1 or 2, if the "Split value active" function has been set (menu 4.2.1 and 4.3.1)

If the current flow value is within the upper sub-domain (split value to full-scale value), the range 0 to URV is shown in a linear way on the set current range as for the inactive Split mode.

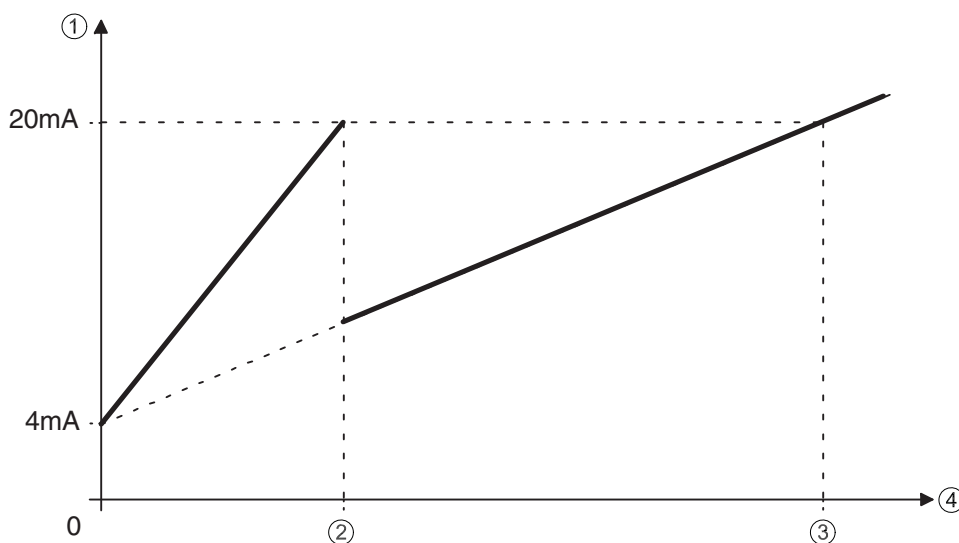

- ① Output current
- ② Split value
- ③ URV
- ④ Flow

Figure 7-5 Split mode in domain 4 ... 20 mA

Profibus (Menu item 4.1)

This menu only appears in PROFIBUS devices. (7ME 5034-1xxxx).

This menu gives you the following setting options:

- Bus address, menu item 4.1.1

The address 126 (factory setting) is reserved for newly connected devices and must be changed to a smaller value at the latest after commissioning on the bus. A value between 30 and 125 is recommended because addresses below 30 are only assigned for bus masters as a rule.

An address < 126 is only addressable when no cyclic communication is taking place and all acyclic connections are closed.

With the PROFIBUS variable "factory_reset = 2712" the address can be reset to the factory setting 126.

Note

Each address may only be assigned for one device on the connected bus!

- Ident No., menu item 4.1.2

The device profile for the cyclic data traffic can be selected here.

You have the following options:

- Profile-specific (=Ident No. 0x9740) means:

Restricted functions; i.e. only cyclic parameters according to profile 3.0 (flow and totalizer net).

- Manufacturer-specific (= Ident No. 0x80C4) means:

Full functions, i.e. cyclic parameters according to profile 3.0 and additional manufacturer-specific parameters (e.g. totalizer forwards, totalizer reverse).

Note

The connected PROFIBUS master must be configured with a device database file (GSD) according to the set ID No.

See also Device Database File (GSD) (Page 103)

Digital output 1 (Menu item 4.2)

You have the following setting options in this menu:

- **Function**, menu item 4.2.1

You can configure digital output 1 as a pulse, frequency, alarm or status output

When "Split value active" is selected, the output is active when the current level of the flow value is within the lower sub domain 0 to

"Split value"; the output current is then scaled to the 0 to "Split value" range. If the flow value exceeds this sub-domain, the output current is scaled to the 0 to URV range.

- **Signal type**, menu item 4.2.2

You can configure different signal types for the output signal of digital output 1:

- Active:

The device-internal voltage is used (+24 V).

- Passive:

External supply required.

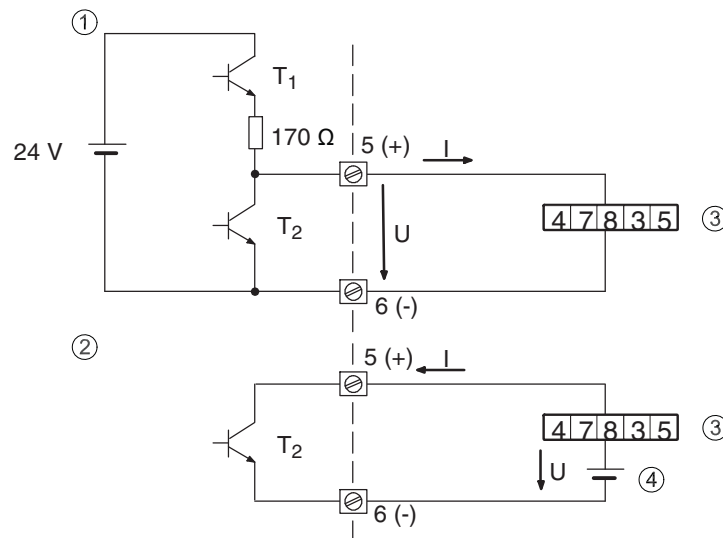

- ① Active
- ② Passive
- ③ Counter
- ④ External supply max. DC 30 V

Figure 7-6 Active and passive signals

You can generate signals with positive and negative logic (positive and negative pulses). The figure below illustrates the setting options.

- **Pulse rate**, menu item 4.2.3

The pulse valence indicates how many pulses are output per unit of volume or mass.

When the "Pulse" function is selected, you have to set the number of pulses per unit of volume or mass.

- **Pulse width**, menu item 4.2.4

You can determine the pulse/pause ratio of the pulse output with the pulse width. The pulse width can be set in a range from 0.1 to 2000 ms. A maximum pulse width is calculated in relation to the set full scale value and the set pulse valence. The maximum pulse frequency is 5 kHz.

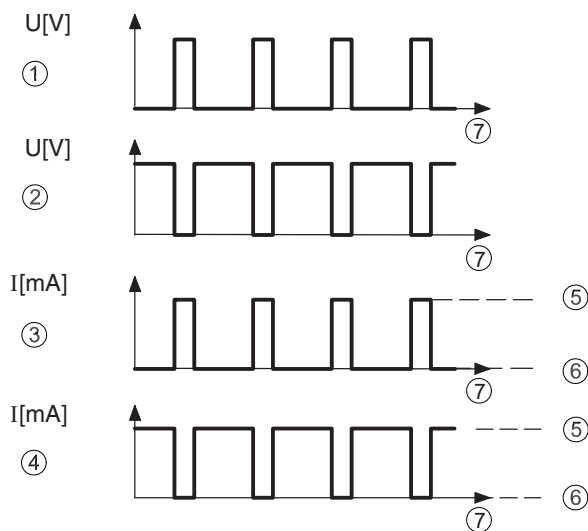

- ① Active-positive
- ② Active-negative
- ③ Passive-positive
- ④ Passive-negative
- ⑤ Transistor T₂ conductive
- ⑥ Transistor T₂ disabled
- ⑦ Time

Figure 7-7 Signal types for digital output 1

- **Full scale frequency**, menu item 4.2.5

The frequency is permanently assigned to the flow. The pulse/pause ratio is constant 1:1. If the "Full scale frequency" function is selected, the frequency is set in the range from 2 ... 10000 Hz.

Digital output 2 (Menu item 4.3)

The digital output 2 is available in device variants with the MLFB-No. 7ME5034-0xxxx-xxxx (Hart communication and digital output). You have the following setting options in this menu:

- **Function**, menu item 4.3.1

You can configure the digital output 2 (relay contact) as an alarm or status output.

When "Split value active" is selected, the output is active when the current level of the flow value is within the lower sub-domain 0 to "Split value". In this case the output current is scaled to the 0 to "Split value" range. If the flow value exceeds this sub-domain, the output current is scaled to the 0 to URV range.

Note

The relay contact is open in the "no function" setting.

- **Signal type**, menu item 4.3.2

You can set the function of the relay as follows in this menu item:

1. When the relay need to be closed in the event of an alarm:

Flow in forward direction

Limit value message

2. When the relay need to be open in the event of an alarm:

Flow in forward direction

Limit value message

Table 7- 3 Relay status

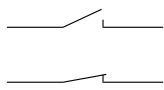
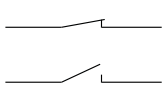
Setting	No alarm Reverse flow No limit signalling	Alarm message Forward flow Limit signalling
1. Contact closes 2. Contact opens		

65F1657-10

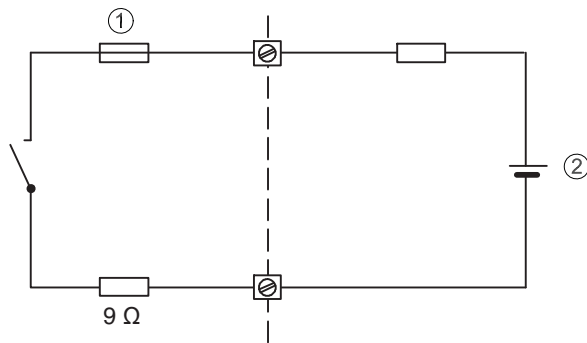

- ① Electronic fuse
- ② External supply

Figure 7-8 Digital output 2

CAUTION
At high inductive loads, the digital output must be protected against transient overvoltage with a suitable external recovery diode.
The electronic fuse is tripped in the event of overloading. The recovery time of the fuse is a few minutes. The relay contact is open in the no-load state.

Digital input (Menu item 4.3)

The digital input is available with the device variant 7ME5034-2xxxx (Hart communication and digital input). You have the following setting options in this menu:

- **Function**, menu item 4.3.1

By applying an external power supply, you can create a switching input, for example using a switch (see also Figure 5-12). You have the following possibilities depending on the configuration:

- Set the measured value to "0" (all outputs and displays are reset to zero and the totalizers are stopped)
- Reset the forwards totalizer
- Reset the reverse totalizer
- Reset the net totalizer
- Reset all totalizers

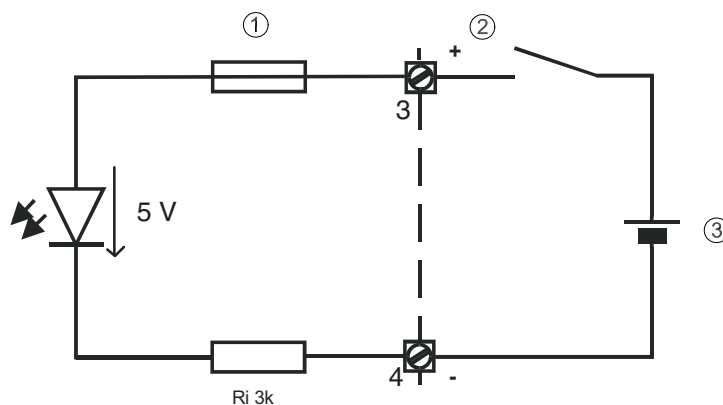

- ① Electronic fuse
- ② External switch
- ③ External supply 11 ... 24 V (max. 30 V)

Figure 7-9 Circuit diagram of digital input

- **Signal type**, menu item 4.3.2

You can determine the signal type (high-active) with this.

7.6 Function Group Identification

Funct. unit (Menu item 5.1)

You can call or enter device-specific or tag-related data in this menu.

You have the following options:

7.6 Function Group Identification

- TAG (tag number), menu item 5.1.1
- Tag description, menu item 5.1.2
- Message, menu item 5.1.3

You can enter tag-specific data in these menu items. The and operating elements take on the function of a cursor control here. The numbers, letters and text characters are selected with the and operating elements.

If no text is stored, the end of text character flashes when opening these menu items. Actuation of the and operating elements moves the end of text character one position to the right and a character can be selected from the character set. The following characters are available:

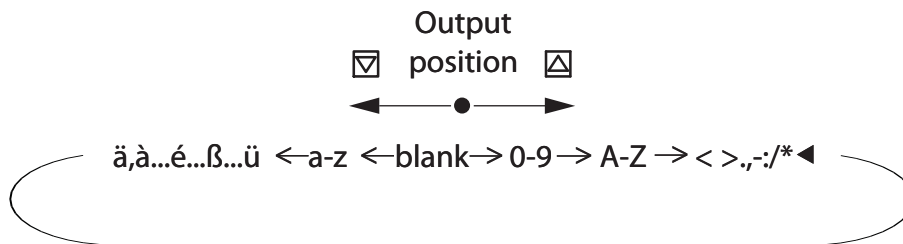

The selected character is transferred by pressing the operating element and the end of text character flashes again. Another character can be selected with the and operating elements. Text input is ended by actuating the operating element when the end of text character flashes.

The number of characters is limited to:

Table 7- 4 Max. number of characters

	PROFIBUS	HART
• Tag number (TAG):	32 characters	8 characters
• Tag name:	32 characters	16 characters
• Tag message	32 characters	32 characters

The Hart communication transmits only capital letters. For texts with more than 16 characters, the marks and in the first and last segment of the device display respectively indicate that there are other characters to the left and/or right of the displayed text.

You delete text by selecting the end of text character from the character set with the and operating elements and then actuating the operating element. All inputs to the right of the end of text character are then deleted.

Note

When the and operating elements are actuated continuously (your finger stays on the glass panel), the characters are scrolled automatically.

Manufacturer data, menu item 5.2

You can read out the serial number, order number and software version of the device in the individual menu items.

The serial number and the order number of the device electronics are always displayed; in case of replaced electronics the latter is different from that of the device rating plate.

- **Nominal width**, menu item 5.2.6.2

In this menu item you can set the nominal width in older generations of sensors manually if no SmartPLUG data are available.

When you have selected "Probe", you must enter the interior diameter of the surrounding tube in "Diameter".

7.7 Function Group Service

Enter Code (menu item 6.1)

You can disable the control and display unit with a personal, freely selectable code number to prevent programming of the device by unauthorized persons. By entering the appropriate code number in this menu item, the programming is enabled and you can change the device settings.

- Factory set code "0"
- Customer code (see menu item 6.2 "Code change")

Note

If you actuate one of the or operating elements in the setting level of the parameter, you are automatically prompted to enter the code in the device display. The programming is disabled after returning to the display mode. The programming can also be disabled by entering any number which does not match the actual customer code in this menu item. After input of '3333' the fixed personal code is briefly displayed (help function as reminder).

Customer code (Menu item 6.2)

You can change the personal code number in this menu item.

The code is factory set to 0. The menu item is only accessible after entering the personal code even when programming has already been enabled.

Note

Programming is always enabled when the code = 0.

Service code (Menu item 6.3)

The calibration data of the device are protected by a special code (factory code). The appropriate menu items are only available after entering this factory code.

Reset (Menu item 6.4)

Here you can perform a "warm start" of the controller.

This retains all saved units, but the volume totalizer is reset to zero.

Control values (Menu item 6.5)

These display values are for trained service personnel, since they are device-internal data mainly for error diagnosis.

These include:

- **Magnet voltage Um, Uref**, menu item 6.5.1
- **Signal voltage Usig**, menu item 6.5.2
- **Electrode voltage Uel1**, menu item 6.5.3
- **Electrode voltage Uel2**, menu item 6.5.4
- **Current flow** in % of the set full scale value, menu item 6.5.5
- **Measuring frequency**, menu item 6.5.6
- **Self test**, menu item 6.5.7
- **Service information**, menu item 6.5.8
- **Digital input**, menu item 6.5.9

Zero Trim (Menu item 6.6)

This function is divided into:

- **Zero flow correction**, menu item 6.6.1

This menu item serves to adapt the local hydraulic conditions. The zero point has a speed value of -1 to +1 m/s added. This setting is undone by entering "0".

- **Start correction**, menu item 6.6.2

This automatically determines the hydraulic zero point. This value is visible in menu item 6.6.1 and can be adapted there, if necessary, or undone by entering "0".

Trim param. (menu item 6.7)

You have the following setting options in this menu:

- **Calibration factor**, menu item 6.7.1
 Due to the local hydraulic conditions, any error related to the full scale value is corrected in this menu item. The value to be set here corresponds to a multiplier of the measured value.
 An absolutely correctly set zero point is the prerequisite for proper functioning.
- **CFH**, menu item 6.7.2
 This is a factory determined hydraulic calibration value at a flow of 1 m/s. This value is automatically taken from the SmartPLUG of the measuring sensor. For older measuring sensors without a SmartPLUG, the value must be transferred manually from the nameplate.
- **CFR**, menu item 6.7.2
 This is a calibration value for the reference inductor in the measuring sensor calculated in the factory. This value is automatically adopted by the SmartPLUG.
- **ZPH**, menu item 6.7.3
 This is a factory-determined hydraulic calibration value at a flow of 0 m/s. This value is automatically taken from the SmartPLUG of the measuring sensor. For older measuring sensors without a SmartPLUG, the value must be transferred manually from the nameplate.
- **Excitation frequency**, menu item 6.7.4
 This setting option depends on the type or the nominal width of the sensor or the probes.

Signal Transmitter	Sensor	Nominal width	Magnet frequency (=mains frequency)
TRANSMAG 2	911/E Standard applications	(all)	Bipolar prepulse f/5
	911/E Rapid applications	(all)	Bipolar f/3
	911/E up to 1995	DN ≤ 150	Unipolar f/6

- **Immersion check**, menu item 6.7.5
 The "Tube empty" detection depends basically on the conductivity of the medium. The switching threshold is set to a typical value.
 Adjustment may be necessary in special cases.
 Here you have to determine the current internal measured values for electrodes 1 and 2 for a filled and empty measuring tube under the menu items 'Act.Value EI1' and 'Act.Value EI2'. The switching threshold of the immersion check should be set under menu item 'Threshold' to about midway between these two values.

8.1 Maintenance

The device is maintenance-free, however, a periodic inspection according pertinent directives and regulations must be carried out.

An inspection can include check of:

- Ambient conditions
- Seal integrity of the process connections, cable entries, and cover screws
- Reliability of power supply, lightning protection, and grounds

8.2 Cleaning

Use only mild cleaning agent to clean the transmitter. "Aggressive" agents such as hydrochloric acid (even diluted), alcohol or abrasive media may not be used.

8.3 Changing fuses

 WARNING
--

Disconnect the device from the mains at all poles before opening it.
--

The fuses may only be changed by qualified personnel.

- The device fuse of the transmitter is located on the power supply board.
The device fuse type used is:
 - T 1.6 A / 250 V H (cutoff capacity 1500 A); 5.2 x 20.
- The magnetic current fuse is located on the measurement board.
The magnetic current fuse type used is:
 - F 5A/250 V, IEC 127, 5,2 x 20 mm

CAUTION

The fuses can only be replaced by fuses of the same type.

Fuse for
power
supply

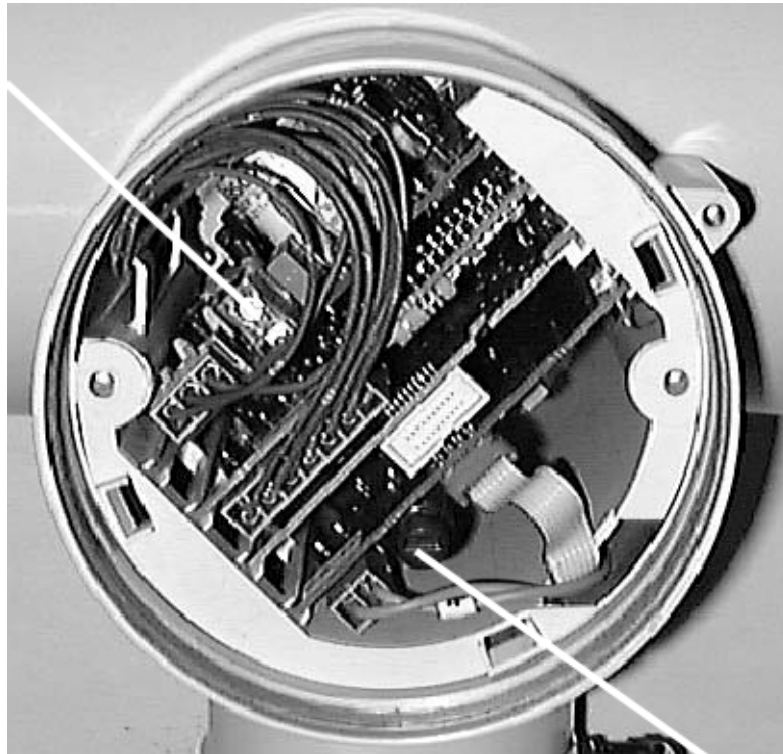

Magnetic current
fuse

Position of the fuses

8.4 Recalibration

Siemens Flow Instruments offers to recalibrate the sensor. The following calibrations are offered as standard:

- Standard matched pair calibration
- Customer specified matched pair calibration (up to 10 points)
- Accredited matched pair calibration

Note

For recalibration the memory unit must always be returned with the sensor

See also

Return procedures (Page 64)

8.5 Technical support

If you have any technical questions about the device described in these Operating Instructions and do not find the right answers, you can contact Technical Support:

- Via the Internet using the **Support Request:**
Support request (<http://www.siemens.com/automation/support-request>)
- Via Phone:
 - Europe: +49 (0)911 895 7222
 - America: +1 423 262 5710
 - Asia-Pacific: +86 10 6475 7575

Further information about our technical support is available in the Internet at Technical support (<http://support.automation.siemens.com/WWW/view/en/16604318>)

Service & Support on the Internet

In addition to our documentation, we offer a comprehensive knowledge base online on the Internet at:

Service and support (<http://www.siemens.com/automation/service&support>)

There you will find:

- The latest product information, FAQs, downloads, tips and tricks.
- Our newsletter, providing you with the latest information about your products.
- A Knowledge Manager to find the right documents for you.
- Our bulletin board, where users and specialists share their knowledge worldwide.
- You can find your local contact partner for Industry Automation and Drives Technologies in our partner database.
- Information about field service, repairs, spare parts and lots more under "Services."

Additional Support

Please contact your local Siemens representative and offices if you have additional questions about the device

Find your contact partner at:

Local contact person (<http://www.automation.siemens.com/partner>)

8.6 Return procedures

Enclose the delivery note, the cover note for return delivery together with the declaration of decontamination form on the outside of the package in a well-fastened clear document pouch.

Required forms

- **Delivery Note**
- **Cover Note for Return Delivery** with the following information

Cover note

- product (ordering number)
- number of devices or spare parts returned
- reason for the return

- **Declaration of Decontamination**

Declaration of Decontamination

With this declaration you certify *that the returned products/spare parts have been carefully cleaned and are free from any residues.*

If the device has been operated together with toxic, caustic, flammable or water-damaging products, clean the device before return by rinsing or neutralizing. Ensure that all cavities are free from dangerous substances. Then, double-check the device to ensure the cleaning is completed.

We shall not service a device or spare part unless the declaration of decontamination confirms proper decontamination of the device or spare part. Shipments without a declaration of decontamination shall be cleaned professionally at your expense before further proceeding.

You can find the forms on the Internet and on the CD delivered with the device.

See also

Decontamination declaration

(http://pia.khe.siemens.com/efiles/feldg/files/Service/declaration_of_decontamination_en.pdf)

Return delivery form (<http://support.automation.siemens.com/WW/view/en/16604370>)

Troubleshooting

9.1 Quick sensor check-up

Resistance check

Between the sensor terminals 5 and 6, the resistance should be between 8 and 20 Ω , when the transmitter is disconnected. If the measured value is outside the recommended area, the sensor is defective.

Isolation check

Between sensor terminal 5 and 7 as well as 6 and 7, the resistance must be ≥ 10 M Ω . If this is not the case, humidity is present in the sensor. The check can also be carried out with the sensor cable connected. If the measured values are too low, the sensor is defective.

CAUTION

Make sure the transmitter is disconnected during resistance and isolation check!
--

Check of electrode circuit

For sensors with SmartPLUG, the voltage must be:

- - 5.3 V DC \pm 10% between terminal 22 and 29
- + 5.3 V DC \pm 10% between terminal 22 and 30

This should be measured directly at the transmitter and then at the sensor.

If the measured values are too low, transmitter is defective.

If the measured values are zero or with a wrong polarity, check cable leads.

See also

If the sensor or transmitter is defective, contact your local Siemens representative:

Local contact person (<http://www.automation.siemens.com/partner>)

9.2 Application Problems

Table 9- 1 Troubleshooting list

Error	Diagnosis	Remedy
Sensor does not work or no display or no output signal	Power supply missing	Connect or switch on power supply
	Device fuse defective	Check device fuse and replace if necessary (see Changing fuses (Page 61))
Transmitter does not react to controls	Reflections in the glass	Clean glass
	Glass is not tight to the operating unit	Screw in the electronic cover tightly
Transmitter cannot be parameterized by the operating module	Personal code is activated	Enter personal code (menu 6.1 or deactivate by entering 0 in menu 6.2)
	Local operation lock activated by HART or PROFIBUS	Cancel operation lock
Output signal OK but no display visible	Ambient temperature outside permissible range	Remote design: bring transmitter into a temperature range of 0 to 50 °C
	Display defective	Change operating module
Flow display = 0 at available flow	Low flow cut-off set too high	Reduce low flow cut (menu 3.1.6)
	Flow opposite to preferable direction at setting of measuring direction to "forwards only"	Switch over preferred direction menu (3.1.5.1) or set measuring direction to "forw.+rev." (menu 3.1.5.2)
	Measured value set to 0 via digital input	Switch over signal at digital input (menu 4.3.2) or switch off function (menu 3.3.1)
	Cable connection to sensor defective (only for remote design)	Check cable connection and exchange as required
	SmartPLUG defective	Have SmartPLUG exchanged (only by service personnel)
Transmitter indicates flow at zero flow	Hydraulic zero point drift, application-dependent	Perform zero correction (menu 6.6.2) or enter correction value directly (menu 6.6.1)
	Earthing problems	Provide potential equalization (see Potential equalization of sensor (reference potential) (Page 17))
Fluctuating measuring results at constant flow	Air, gas occlusions	Eliminate gas occlusions or use gas trap
	Earthing problems	Provide potential equalization (see Potential equalization of sensor (reference potential) (Page 17))
	Vibrations in the sensor and/or in the cable run	Fix the sensor better, strap cables
	Medium conductivity too low	Check conductivity; measuring method may be unsuitable
	Proportion of solids too high	Reduce proportion of solids, measuring method may be unsuitable
	Very unstable measurement, strongly fluctuating values, output going towards zero	Check for moisture in SmartPlug If fitted with round SmartPlug call factory product support
Measuring deviations, measuring errors	Inlet and outlet lines insufficient	Change installation (see Sensor installation (Page 13))

Error	Diagnosis	Remedy
	Highly turbulent flow profile	Change inlet line, use flow rectifier, reduce diameter of tube
	For mass measurement: medium density set incorrectly	Correct density according to current medium (menu 3.1.4)
	Hydraulic calibration values faulty	Check hydraulic calibration values CFH and ZPH. According to the sensor rating plate and correct if necessary (menus 6.7.2 and 6.7.3).
	Electric calibration faulty	Run self-test (menu 2.4.1); Check device status (menu 2.1): if "Calibration failure measuring module" is displayed, send in the complete electronics for repair
	Application-dependent calibration values faulty	Reset zero point correction (menu 6.6.1) to 0 and/or reset calibration factor (menu 6.7.1) to 1.0. Alternatively: Make zero correction (menu 6.6.2) and manual adaptation of the calibration factor (menu 6.7.1)
Measured value too low at dosing	Set attenuation too high	Reduce filter time constant (menu 3.1.7.1)
	Fault blanking activated	Deactivate noise suppression (menu 3.1.7.3)
	Magnetic field frequency too low	Device may not be suitable for this application
	Magnetic field frequency too low	Change excitation to Bipolar (menu 6.7.4)
Measured value too low in pulsed flow	Temporary exceeding of internal working range	Increase URV (menu 3.1.2)
	Unfavorable hydraulic conditions	Install sensor on the suction side of the corresponding pump or in front of the feeding valve
	Unfavorable hydraulic conditions	Change excitation to Bipolar (menu 6.7.4)
Output current does not correspond to the current flow and remains at a constant value	There is a fault, failure signal 3.6, 22 or 24 mA is output (depending on the setting under menu 4.1.2)	Determine source of fault under device status (menu 2.1)
	Load too high	Reduce total load including the resistance to < 600 Ω
	Current output or power supply defective	Replace complete electronics
Communication via HART not possible	Minimum load of 230 Ω not available	Increase load to at least 230 Ω and connect HART Modem/Communicator parallel to this load
Communication via PROFIBUS not possible	Device address set incorrectly (assigned more than once on the same bus or not configured in the master)	Correct address under menu 4.1.1 or request and correct by acyclic communication
	Current load on bus too high for connected feeding device	Try disconnecting other devices from the bus Adapt the feeding device if necessary
	Baud rate between master and coupler/link not correct	Adapt baud rate to coupler/link
	More than two bus terminations exist (incl. coupler and link)	Reduce to two bus terminations
	PROFIBUS interface defective	Check device status (menu 2.1): if "COM module failure" is signaled, replace the complete electronics

9.3 Error messages

Errors are indicated by a flashing "D" (Device error) or "F" (Measurement error) in the top right hand corner of the local display.

Table 9- 2 Error messages

Error		Diagnosis	Remedy
D	Flashing "D" in the top right hand corner of the display	General device error (see also section 5.3.2)	Menu 2.1 Call device status
D	Device status (menu 2.1) "Memory failure"	Internal memory defective	Replace complete electronics
D	Device status (menu 2.1) "COM Module failure"	HART interface not available in the transmitter PROFIBUS interface not available in the transmitter	Replace complete electronics
D	Device status (menu 2.1) "Software failure"	General software error	Do a restart (menu 6.4); If error persists: have firmware reloaded (by service personnel), alternatively: replace complete electronics
D	Device status (menu 2.1) "Sensor failure"	Magnetic field current fuse defective	Change magnetic field current fuse (see section 6.3.1)
		Magnetic current cable defective (at terminals 5 and 6 in remote design)	Check cable and change if necessary
		Magnet coil defective	Check on remote design: Switch off device, disconnect magnetic field current cable, measure resistance at terminals 5 and 6 on sensor: setpoint: 8 ... 20 Ω. Otherwise: change sensor
		Reference coil improperly connected (terminals 55, 66)	Check cable and replace if necessary
		Electronics defective	Change complete electronics
D	Device status (menu 2.1) "Flow measurement disturbed"	No measurement possible (group message)	Change complete electronics
	"SmartPLUG read failure"	Connected sensor without SmartPLUG or defective SmartPLUG	Check parameterization (range, unit etc.) A correct measurement is still possible when the calibration values CFH and ZPH match the values on the rating plate of the sensor. Check whether this is the case and correct if necessary under the menus 6.7.2 and 6.7.3
F	Flashing "F" in the top right hand corner of the display	General incorrect measurements, process errors or incorrect parameterization.	Menu 2.1 Call device status
F	Device status (menu 2.1) "Measurement module failure"	Measuring range overflow	Reduce flow quantity or increase upper range value in menu 3.1.2
F	Device status (menu 2.1) "Measurement module"	Measuring electronics defective	Measurement with reduced accuracy still possible; replace complete electronics

Error		Diagnosis	Remedy
		Defective immersion check	Deactivate immersion check (menu 2.3)
		Magnetic field current outside the calibrated range	Recalibrate unit
		Fault in measuring function (incorrect measuring frequency)	Turn off mains synchronization (menu 3.1.7.2).
F	Device status (menu 2.1) "Calibration failure measuring module"	Self-test made with the result: measuring tolerances too high in relation to factory calibration	Electronics must be recalibrated, send in device (See chapter Return procedures (Page 64))
F	Device status (menu 2.1) "Simulation is running"	Device not in "Measure" status, Simulation is switched on	End simulation (exit the menu "Simulation" 2.5.2, 2.5.3 or 2.5.4 or select "End" in menu 2.5.1. Alternatively: Restart the device
F	Device status (menu 2.1) "Calibration is running"	Zero calibration (menu 6.6.2) started and active	Device returns to measuring mode automatically at the end of calibration
F	Device status (menu 2.1) "Tube empty" (only possible with immersion check : menu 2.3) activated)	Measuring tube empty or only partially filled	Fill measuring tube with medium, ensure it is completely full
		High percentage of gas	Clear gas occlusions or use gas trap
F	Device status (menu 2.1) "Flow measurement uncertain"	Electrode DC voltage outside permitted range	Clean sensor electrodes
F	Device status (menu 2.1) "Measuring range overflow"	Current flow too high	Reduce flow
		Full scale value set too low	Increase upper range value in menu 3.1.2 or reduce flow rate

9.4 Application information guide

In case the device needs service, the factory will typically request information about application and flowmeter.

Fill in this form and attach it to a Support request on:

Service and support (<http://www.siemens.com/automation/service&support>)

To: Siemens Flow Instruments A/S A&D PI 3 Fax: +45 7449 0066	From: Company: E-mail: Phone no.: Fax no.:
--	---

Note

Sketch

It is recommended to prepare a diagram/sketch of the installation/application explaining inlet and outlet conditions; distance from pump; etc.

Table 9- 3 Application data

Liquid	
• Media conductivity	
• Media name	
• Chemical formula	
• Gas (%-vol)	
• Solids - kind and concentration (%-weight)	
• Media density	
• Media viscosity	
Pipe size	
Process temperature	
Ambient temperature	
Process pressure	
Liner type	

Table 9- 4 Sensor/converter data

Serial-No./Komm.-nr. transmitter	Type plate	
Order No. converter	Menu 5.2.1	7ME
Serial-No./Komm.-nr. sensor	Type plate	
Order No. sensor	Menu 5.2.6.2	7ME
Current flow	Menu 1.3	
Flow velocity [m/s]	Menu 1.5	
Current output [mA]	Menu 1.7	
Device status / error messages	Menu 2.1	
Engineering unit	Menu 3.1.1	
Flow upper range value (URV)	Menu 3.1.2	
Flow direction (+/-)	Menu 3.1.5.1	
Measuring direction (forward/reverse)	Menu 3.1.5.2	
Hysteresis	Menu 3.1.5.3	
Low flow cut-off (1%)	Menu 3.1.6	
Time constant (3.00 sec.)	Menu 3.1.7.1	
Slurry mode (off)	Menu 3.1.8	
Pulse rate / unit	Menu 4.2.3	
Pulse width	Menu 4.2.4	

Full scale frequency (10 000 Hz)	Menu 4.2.5		
Volt UM (magnetic current) (23 100 - 30 500)	Menu 6.5.1		
Volt Uref (magnetic ref. voltage)	Menu 6.5.1		
Volt Usig	Menu 6.5.2		
Volt Uel1 and DC voltage on electrodes measured on terminals 22 to 23 from sensor	Menu 6.5.3	Menu	Terminal
Volt Uel1 and DC voltage on electrodes measured on terminals 22 to 24 from sensor	Menu 6.5.4	Menu	Terminal
Coil value (terminal 5 and 6 on sensor)			
Isolation value between terminals 5/6 to 7 (min 10 MOhm)			
Ref-coil value between terminals 55 and 66 [Ohm]			
Sample frequency (approx. 2 x magnetic frequency)	Menu 6.5.6		
Service info (coded service information)	Menu 6.5.8		
Cal. factor (1.0)	Menu 6.7.1		
CFH value (are sensor and transmitter data the same?)	Menu 6.7.2		
CFR value (are sensor and transmitter data the same?)	Menu 6.7.2		
ZPH value (are sensor and transmitter data the same?)	Menu 6.7.3		
Excitation frequency (bipolar PP)	Menu 6.7.4		
Grounding sensor (correct?)	See system information		

Technical data

Mode of operation

Table 10- 1 Operation mode

Measuring principle	Electromagnetic with pulsed alternating field (PAC)
Magnetic field excitation	Automatic power supply synchronization
50 Hz AC power supply	<ul style="list-style-type: none"> • Bipolar 16.7 Hz • Bipolar with prepulse 10 Hz • Unipolar 8,33 Hz
60 Hz AC power supply	<ul style="list-style-type: none"> • Bipolar 20 Hz • Bipolar with prepulse 12 Hz • Unipolar 10 Hz

Outputs and inputs

Table 10- 2 Outputs and Inputs

Electrical isolation	Outputs electrically isolated from each other and from the power supply, max. 60 V permissible against PE/ equipotential bonding
Current output	0/4 ... 20 mA (Only 20 mA / HART devices (7ME5034-0.... and -2.....))
Signal range	
Upper limit	0/4 ... 20 mA, selectable
Failure signal	20 ... 22.5 mA
Load	3.6 mA, 22 mA or 24 mA
Output	Max. 600 Ω , load voltage max. 15 V For HART communication: $\geq 250 \Omega$
Communication	Via analog output with PC coupling module or HART communicator
Protocol	HART version 5.1
Digital output 1	
Signal	
Output	Configurable for positive or negative logic
Active signal	DC 24 V, ≤ 24 mA, $R_i = 170 \Omega$
Passive signal	Open collector, max. DC 30 V, 200 mA
Output configuration	
Pulse	

Significance	≤ 5000 pulses/s
Pulse width	≥ 0.1 ms
Frequency	≤ 10.000 Hz
Limits	For flow and quantity, flow direction, alarm
Digital output 2 (relay)	only 7ME5034-0....
Relay	NC or NO function
Rating	Rating max. 5 W, UC 50 V, 200 mA
Output configuration	limits for flow and quantity, flow direction, alarm
Digital input	Only as alternative to digital output 2 (only 7ME5034-2....)
Input function configurable high or low active	Set measured value or counter to zero
Signal voltage	max. 30 V, Re = 3 k Ω
High level	DC +11 to 30 V
Low level	DC -30 to +5 V
PROFIBUS-PA	For PROFIBUS devices (7ME5034-1....)
Communication	Layer 1 and 2 according to PROFIBUS-PA
Transmission	According to IEC 1158-2
Protocol layer	Layer 7 according to PROFIBUS-PA and DP V1 (EN 50170)
Device class	B
Device profile	3.0; max. 4 simultaneous C2 connections
Bus voltage	Permissible 9 to 32 V
Current consumption from bus	10 mA, limited to ≤ 15 mA in the event of an error by electrical current limitation

Measuring accuracy under reference conditions

Table 10- 3 Measuring accuracy

Measuring tolerance of pulse output	
At $v > 0.25$ m/s (0.82 ft/s)	≤ 0.5 % of the measured value, ± 0.0012 m/s (0.0039 ft/s)
At $v < 0.25$ m/s (0.82 ft/s)	≤ 0.0025 m/s (0.0082 ft/s)
Measuring tolerance of analog output 4 to 20 mA	Same as pulse output; plus ± 0.1 % conversion error ± 20 μ A
Repeatability	0.2 % of the measured value

Reference conditions

Table 10- 4 Reference conditions

Medium process temperature	$+25$ °C ± 5 °C (77 °F ± 9 °F)
Ambient temperature	$+25$ °C ± 5 °C (77 °F ± 9 °F)
Warm-up time min.	30 min

Installation conditions	
Inlet pipe section	$\geq 10 \times \text{DN}$
Outlet pipe section	$\geq 5 \times \text{DN}$; installed centered to pipe
Medium	water without gaseous and solid parts
Conductivity	$> 200 \mu\text{S/cm}$
Magnetic current frequency	bipolar with prepulse

Related operating conditions

Table 10- 5 Related operating conditions

Ambient temperatures	
Remote design	$-20 \text{ }^\circ\text{C}$ to $+60 \text{ }^\circ\text{C}$ ($-4 \text{ }^\circ\text{F}$ to $+140 \text{ }^\circ\text{F}$)
Display unit	$0 \text{ }^\circ\text{C}$ to $+50 \text{ }^\circ\text{C}$ ($32 \text{ }^\circ\text{F}$ to $122 \text{ }^\circ\text{F}$)
Storage	$-25 \text{ }^\circ\text{C}$ to $+80 \text{ }^\circ\text{C}$ ($-13 \text{ }^\circ\text{F}$ to $+176 \text{ }^\circ\text{F}$)
Degree of protection	IP67, NEMA 4X, 5
Electromagnetic compatibility (EMC)	
Emitted interference	According to EN 61236 for use in industrial areas
Noise immunity	<ul style="list-style-type: none"> According to EN 61326 for use in industrial areas According to NAMUR NE21 for use in residential areas
Medium conditions	
Minimum conductivity of the medium	$\geq 1 \mu\text{S/cm}$, on request $0,1 \mu\text{S/cm}$, depending on medium

Design

Table 10- 6 Design

Weight of transmitter	4.4 kg (9.7 lb)
Remote version	Transmitter must be connected to the sensor using shielded cables
Maximum cable length	100 m; (328 ft)
Housing	Die-cast aluminum, painted

Local display

Table 10- 7 Display

General display	LCD, background illumination, two lines with 16 characters each
Multi-display	For flow, quantity, flow velocity
Keypad	4 operating elements for entering parameters

Power supply

Table 10- 8 Power supply

AC voltage	AC 100 to 250 V, $\pm 15\%$, 47 to 63 Hz
Power consumption	Approx. 120 to 630 VA, dependent on sensor
Power failure	Bridging of at least 1 power supply cycle (> 20 ms)
Cable fuse	AC 100 to 230 V: T1.6A
Magnetic current fuse	F5A/250 V

10.1 Dimensions

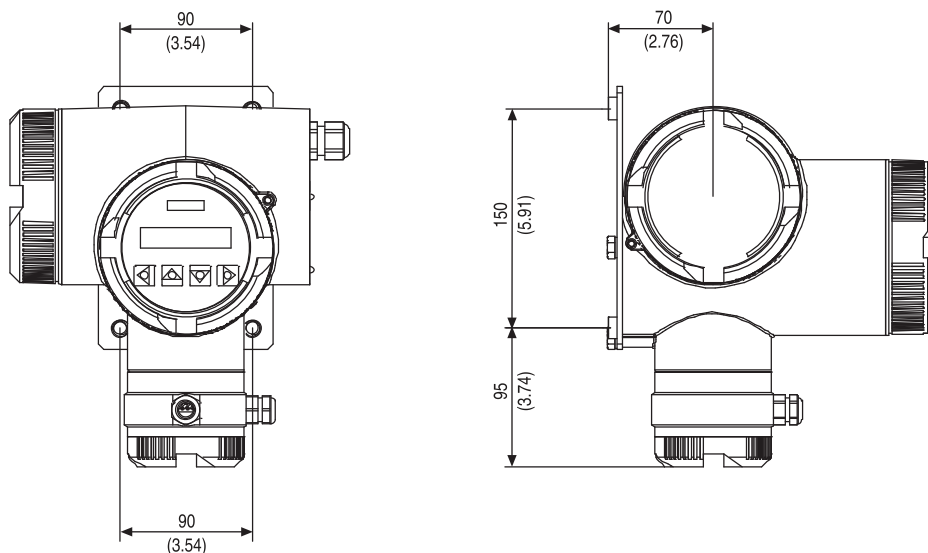

Figure 10-1 SITRANS FM TRANSMAG 2 transmitter with standard mounting plate

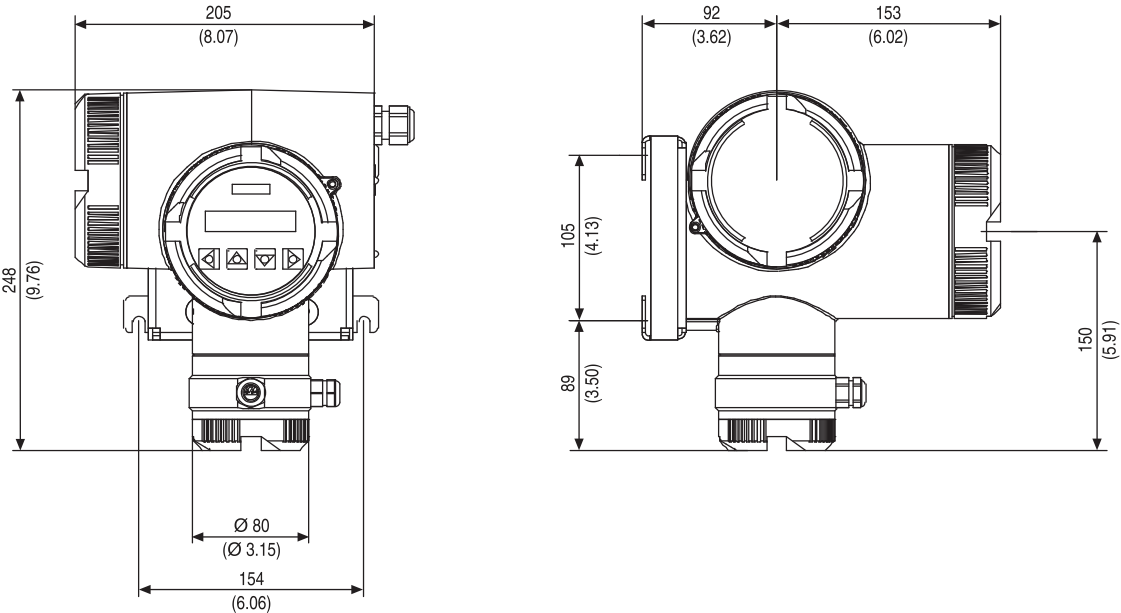

Figure 10-2 SITRANS F M TRANSMAG 2 transmitter with optional mounting plate for pipeline mounting

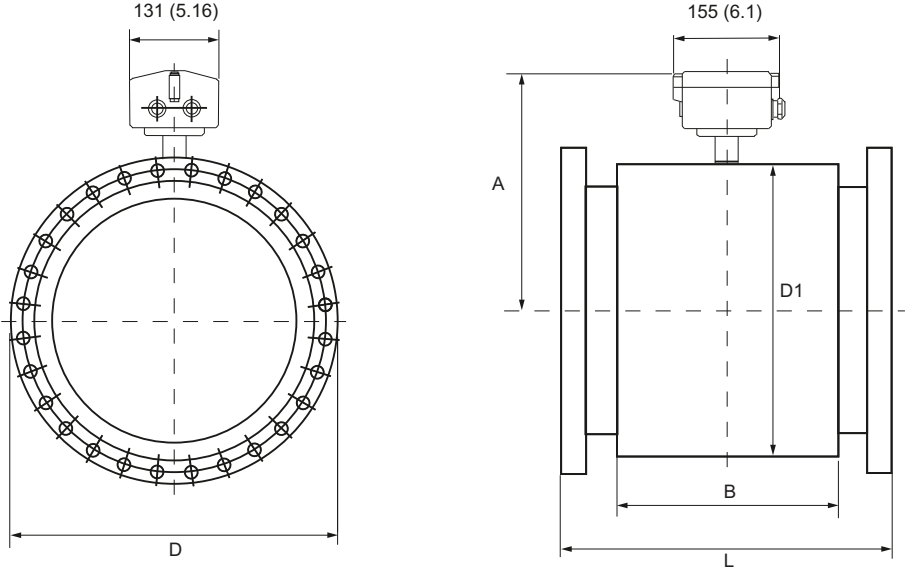

Figure 10-3 SITRANS F M flow sensor 911/E

Technical data

10.1 Dimensions

Table 10- 9 Dimensions, nominal diameter DN 15 ... DN 100

Nominal diameter	DN 15	DN 25	DN 40	DN 50	DN 65	DN 80	DN 100
	½"	1"	1½"	2"	2½"	3"	4"
Built-in length (L)							
• Hard rubber version	270 (10.63)			330 (12.99)		340 (13.39)	
• Linatex / neopren version	270 (10.83)			330 (12.99)		340 (13.99)	
• PTFE-liner without protection rings	270 (10.83)			330 (12.99)		340 (13.99)	
• Novolak-version	-			275 (10.83)	325 (12.79)	335 (13.19)	333 (13.11)
Dimensions of sensor housing							
Width	170 (6.69)						
Height	206 (8.11)		222 (8.74)	229 (9.02)	262 (10.32)		274 (10.79)
Diameter	135 (5.35)		167 (6.58)	182 (7.17)	247 (9.73)		272 (10.71)

Weight of PN 16	8.0	8.5	11.5	25.0	26	27	28
Version in kg (MWP 145 psi Version in lb)	(17.6)	(18.7)	(25.4)	(55.1)	(57.3)	(59.5)	(61.7)

Table 10- 10 Dimension, nominal diameter DN 125 ... DN 400

Nominal diameter	DN 125	DN 150	DN 200	DN 250	DN 300	DN 350	DN 400
	5"	6"	8"	10"	12"	14"	16"
Built-in length							
• Hard rubber version	370 (14.57)		410 (16.14)	470 (18.50)	500 (19.68)	550 (21.65)	600 (23.62)
• Linatex / neopren version	370 (14.57)		410 (16.14)	470 (18.50)	500 (19.68)	550 (21.65)	600 (23.62)
• PTFE-liner without protection rings	370 (14.57)		410 (16.14)	470 (18.50)	500 (19.68)	550 (21.65)	600 (23.62)
• Novolak-version	362 (14.25)		401 (15.79)	460 (18.11)	489 (19.25)	538 (21.18)	592 (23.31)
Dimensions of sensor housing							
Width (B)	170 (6.69)		240 (9.45)			225 (8.86)	250 (9.84)
Height (A)	286 (11.26)	299 (11.78)	334 (13.15)	258 (14.10)	383 (15.08)	375 (14.76)	400 (15.75)
Diameter (D ₁)	296 (11.65)	322 (12.68)	392 (15.43)	440 (17.32)	490 (19.29)	474 (18.66)	524 (20.63)
Weight of PN 10 Version in kg (MWP 145 psi Version in lb)	34 (75.0)	38 (83.8)	68 (149.9)	81 (178.6)	95 (209.4)	118 (260.2)	161 (354.9)

Table 10- 11 Dimension, nominal diameter DN 450 ... DN 1000

Nominal diameter	DN 450	DN 500	DN 600	DN 700	DN 750	DN 800	DN 900	DN 1000
	18"	20"	24"	28"	30"	32"	36"	40"
Built-in length								
• Hard rubber version	650	650	780	910		1040	1170	1300
• Linatex / neopren version	(25.59)	(25.59)	(30.71)	(35.83)		(40.95)	(46.06)	(51.18)
• PTFE-liner without protection rings	660	650	780	-				
	(25.98)	(25.59)	(30.71)					
• Novolak-version	638	638	772	903		1033	1163	1293
	(25.12)	(25.12)	(30.39)	(35.55)		(40.63)	(45.79)	(50.91)
Dimensions of sensor housing								
Width (B)	270	300	360	420		550	560	620
	(10.63)	(11.81)	(14.17)	(16.54)		(19.69)	(22.05)	(24.41)
Height (A)	433	453	505	558	590	608	658	713
	(17.05)	(17.84)	(19.88)	(21.97)	(23.23)	(23.94)	(25.91)	(28.07)
Diameter (D ₁)	591	629	734	839	904	939	1039	1150
	(23.27)	(24.76)	(28.90)	(33.03)	(35.59)	(36.97)	(40.91)	(45.28)
Weight of PN 10 Version in kg (MWP 145 psi Version in lb)	185	233	401	420	450	500	560	620
	(407.9)	(513.7)	(884.1)	(925.9)	(992.1)	(1102.3)	(1234.6)	(1366.9)

Parameters



The device functions and parameters are listed below with the factory setting and setting option. The menu code only appears in the local display.

Display

Table A- 1 Function group display parameters

Menu code	Device function, Parameters	Description	Factory setting	Setting options
1.1	Display Param.	Setting parameter for the local display		
	Language	Language for user guidance	Deutsch	<ul style="list-style-type: none"> English Deutsch Français Italiano Español Nederlands
1.1.2	Line 1	Definition of measured values to be displayed for line 1 in multi-display	Flow	<ul style="list-style-type: none"> Flow Totalizer net Flow velocity Analog Val. 1, 2, Frequency
1.1.3	Line 2	Definition of measured values to be displayed for line 2 in multi-display	Totalizer net	<ul style="list-style-type: none"> Flow Totalizer net Flow velocity Analog Val. 1, 2, Frequency
1.1.4	Display flow	<p>Selection for type of presentation of the flow rate (% and bargraph only apply to line 2)</p> <p>When the "Flow" parameter has been selected for lines 1 and 2, "Bargraph in %" is always shown in line 2.</p>	Engineering Unit	<ul style="list-style-type: none"> Engineering Unit % Bargraph in %
1.1.5	LCD lighting	<p>Lighting of the display</p> <p>On: permanently switched on</p> <p>Off: automatic switch on by pressing key, switch off after 10 min</p>	Off	<ul style="list-style-type: none"> On Off
1.2	Multi-Display	Simultaneous display of two measuring variables	<p>(actual measured value line 1)</p> <p>(actual measured value line 2)</p>	<ul style="list-style-type: none"> Menu 1.1.2 Menu 1.1.3

Menu code	Device function, Parameters	Description	Factory setting	Setting options
1.3	Flow	Flow value	(actual measured value)	
1.4	Totalizer	Flow quantity since totalizer start; volume or mass, depending on selected unit (menu 3.1.1)	(actual totalizer reading)	
1.4.1	Total. forward	Forward flow only	(actual totalizer reading)	
1.4.2	Total. rev.	Reverse flow only	(actual totalizer reading)	
1.4.3	Total. net	Flow difference forward - reverse	(actual totalizer reading)	
1.4.4	Set (all)	Reset all totalizers simultaneously to zero and stop or start; (separate setting of totalizers, see menu 3.2.1, 3.3.1, 3.4.1)	Cancel	<ul style="list-style-type: none"> • Reset+Stop, • Reset+Start • Cancel
1.5	Flow Velocity	Flow velocity in measuring tube in m/s	(actual measured value)	
1.6	Frequency	Calculated frequency value for actual flow in Hz	(actual measured value)	
1.7	Analog Out 1, 2	Calculated current value for actual flow in mA	(actual measured value)	

Diagnostics

Table A- 2 Function group diagnostics parameters

2.1	Device status	Device status, error messages	("OK" or error messages)	
2.2	Electr.Check	Supervision of electrodes in sensor	Inactive	<ul style="list-style-type: none"> • Active • Inactive
2.3	EmptyTube Det.	Time interval for immersion check of electrodes or deactivation of immersion check. In case of insufficient immersion of both electrodes in conductive medium, 'Tube empty' is reported under device status.	Inactive	<ul style="list-style-type: none"> • Inactive • 15 s • 30 s • 60 s • 120 s • 300 s
2.4	Device Test			
	Self Test	Check device status (duration approx. 60s)		
2.4.2	Display Test	Visual check of local display		
2.5	Simulation			

2.5.1	Flow	Simulation of a flow value; affects all outputs, totalizers, limit values and display. "F" flashes in the top right of the display during simulation and "Simulation" is displayed under device status.		
	Value	Simulation value in % of full scale value	0 %	-110% to +110%
	Time	Duration of simulation After expiration of this time or with input of "End" the normal measuring mode is resumed	End	<ul style="list-style-type: none"> • End • 10 min • 30 min • 60 min
2.5.2	Dig. Out.1	Simulation of output signal at the digital output 1	End	<ul style="list-style-type: none"> • End • 0.1 Hz • 1 Hz • 10 Hz • 100 Hz • 1 kHz, • 10 kHz • Alarm on • Alarm off
2.5.3	Dig. Out.2 ¹	Simulation of the output signal at the digital output 2	End	<ul style="list-style-type: none"> • Alarm on • Alarm off
2.5.4	Analog Out. ^{1, 2}	Simulation of the output signal at the analog output	4 mA	<ul style="list-style-type: none"> • 0 mA • 4mA • 10mA • 12mA • 20mA • Failure signal

1) Parameters apply only to devices with 20 mA/Hart communication and digital output 2 (7ME5034-0xxxx)

2) Parameters apply only to devices with 20 mA/Hart communication and digital input (7ME5034-2xxxx)

Measuring functions

Table A- 3 Function group Measuring functions parameters

3.1	Flow			
3.1.1	Engr. Unit	Engineering unit for volume flow or mass flow Note: When you select a unit of mass flow (see right column), you must enter the actual medium density (menu 3.1.4).	DN 2 ... 12: l/h DN >12: m ³ /h	<ul style="list-style-type: none"> • m³/s, m³/min, m³/h, m³/d • l/s, l/min, l/h • hl/s, hl/min, hl/h • Ml/d • ft³/s, ft³/min, ft³/h, ft³/d • gal/s, gal/min, gal/h, gal/d • Mgal/d • ImpGal/s, ImpGal/min, ImpGal/h, ImpGal/d • g/s, g/min • kg/s, kg/min, kg/h, kg/d • t/min, t/h, t/d • lb/s, lb/min, lb/h, lb/d, • STon/min, STon/h, STon/d • LTon/d
3.1.2	Flow URV	Upper range value (URV) At the analog output the amount of the measured value in the range 0 up to URV is displayed linear to the current range 4 to 20mA, at the digital output 1 to the frequency range 0 to end frequency	Depending on the nominal width according to 2...3m/s	Depending on the nominal width (according to 0.25 ... 12 m/s)
3.1.3	Limits	Absolute values in flow units from menu 3.1.1		
3.1.3.1	Lo Alarm Limit	Lower alarm limit (the lower alarm limit must be smaller than the upper alarm limit)	10% of the URV (depending on the nominal width according to 0.2 ... 0.3 m/s)	Depending on the nominal width (according to -13 ... +13 m/s)
3.1.3.2	Hi Alarm Limit	Upper alarm limit (the upper alarm limit must be greater than the lower alarm limit)	90% of the URV (depending on the nominal width according to 1.8 ... 2.7 m/s)	Depending on the nominal width (according to -13 ... +13 m/s)
3.1.3.3	Hysteresis	Hysteresis for limit values in % of full scale value	1 %	0 to 20 %
3.1.4	Density Engr. Unit Density	Density of the medium Engineering unit of the medium density Density value for calculation of mass flow	kg/m ³ +1000.00 kg/m ³	<ul style="list-style-type: none"> • g/cm³, kg/m³, lb/gal, kg/l, g/l, lb/in³, lb/Impgal • 200 ... 5000 kg/m³
3.1.5	Direction			

3.1.5.1	Flow Direction	Main flow direction related to direction arrow on measuring tube (= forwards, positive flow values)	+Direction	<ul style="list-style-type: none"> +Direction, -Direction
3.1.5.2	Meas.Direction	Output of suppression of reverse flow Affects all outputs, totalizers and display	forw.+rev.	<ul style="list-style-type: none"> forward only, forw.+rev.
3.1.5.3	Hysteresis	Hysteresis of detection of flow direction in % of full scale value	0.2 %	0 to 20 %
3.1.6	Low flow cut	Threshold for low flow cut in % of full scale value 1, 2 or absolute value in flow unit 3	1 %	0 to 20 %
3.1.7	Noise filter			
3.1.7.1	Fltr.Time Con.	Time constant τ for measured value attenuation; after a jump in the measuring variable, the output measured value reaches about 99% of the new setpoint after $5 \cdot \tau$ Does not affect totalizers.	3.00 s	0.0 ... 200.0 s
3.1.7.2	Line Synchron.		Auto mode	Not available
3.1.7.3	Noise Suppress Suppress Time Suppress Limit	Values outside a tolerance range are evaluated for the duration of the blanking time with high attenuation. Time of effect of increased attenuation (0 s = blanking off) Tolerance range = floating average + tolerance value	0 s 0 %	0 ... 100 0 ... 100
3.1.8	Slurry mode	This is used when signals are severely impaired, e.g. for media with a high solids content or air locks	Off	<ul style="list-style-type: none"> On Off
3.2	Total. Forw.	Totalizer forwards		
3.2.1	Set forward	Reset totalizer to zero and stop or start	Cancel 1,2 Totalize 3	<ul style="list-style-type: none"> Cancel 1,2, Reset+Stop, Reset+Start 1,2, Totalize 3
3.2.2	Engr. Unit	Engineering unit of volume or Engineering unit of mass When you select a unit of mass, entry of the actual medium density is mandatory (menu 3.1.4)	DN 2...12: l DN >12: m3	<ul style="list-style-type: none"> l, hl, m3, Ml, ft3, Gal, MGal, ImpGal, MImpGal kg, t, g, lb
3.2.3	Alarm Limit		+1000000 l	-108 ... +108
3.3	Total. rev.	Totalizer reverse		
3.3.1	Set reverse	Reset totalizer to zero and stop or start	Cancel 1,2 Totalize 3	<ul style="list-style-type: none"> Cancel 1,2, Reset+Stop, Reset+Start 1,2, Totalize 3

3.3.2	Engr. Unit	Engineering unit of volume or Engineering unit of mass When you select a unit of mass, entry of the actual medium density is mandatory (menu 3.1.4)	DN 2...12: l DN >12: m ³	<ul style="list-style-type: none"> l, hl, m³, MI, ft³, Gal, MGal, ImpGal, MImpGal kg, t, g, lb
3.3.3	Alarm Limit		-1 000 000 l	-108 to +108
3.4	Total. net	Totalizer forw./rev.		
3.4.1	Set net	Reset totalizer to zero and stop or start	Cancel 1,2 Totalize 3	<ul style="list-style-type: none"> Cancel 1,2, Reset+Stop, Reset+Start 1,2, Totalize 3
3.4.2	Engr. Unit	Engineering unit of volume or Engineering unit of mass When you select a unit of mass, entry of the actual medium density is mandatory (menu 3.1.4).	DN 2...12: l DN >12: m ³	<ul style="list-style-type: none"> l, hl, m³, MI, ft³, Gal, MGal, ImpGal, MImpGal kg, t, g, lb
3.4.3	Lo Alarm Limit	Lower alarm limit (the lower alarm limit must be smaller than the upper limit.)	-1 000 000 l -	Frequency 108 ... +108
3.4.4	Hi Alarm Limit	Upper alarm limit (the upper alarm limit must be greater than the lower limit.)	+1 000 000 l	-108 ... +108
3.4.5	Hysteresis	Hysteresis for limit values	0 l	0 ... +108 (Unit the same as the counter unit in the menu 3.4.2)

Device Outputs

Table A- 4 Function group Device outputs parameters

4.1	Analog Out ^{1, 2}	Analog output 4 to 20mA with HART communication		
4.1.1	Current limit	Upper limit of analog current	22 mA	20 ... 22.5mA
4.1.2	Error signal	Output current in case of failure. With the setting "Hold ..s" a current of 3.6 mA is only output in the case of a longer failure, shorter failures are bridged with output of the last valid current	3.6 mA	<ul style="list-style-type: none"> 3.6mA, 22mA, 24mA, Hold continuous, Hold 5s, 20s, 40s, 60s, 120s, 240s
4.1.3	Current range	Selecting the current range at the analog output on which the measuring range (menu 3.1.2) is shown. For the setting 0 to 20 mA the failure signal (menu 4.1.2) must be set to 22 or 24 mA.	4 ... 20 mA	<ul style="list-style-type: none"> 4 ... 20 mA; 0 ... 20 mA

4.1.4	Split mode	The split mode divides the measuring range into two domains: <ul style="list-style-type: none"> Domain 1 from 0 to 'Split value' Domain 2 from 'Split value' to 'URV' (upper range value, menu 3.1.2) At digital outputs 1 or 2, it is possible to indicate whether the current measured value is within domain 1. To do this, the function 'Split value active' must be set (menu 4.2.1 and 4.3.1)	Inactive	<ul style="list-style-type: none"> Inactive Active
	Split value	End value of domain 1 (only when 'Split mode = active')	URV (menu 3.1.2)	Depends on the nominal width (corresponding to 0.25 ... 12 m/s, <URV)
4.1	PROFIBUS ³	PROFIBUS communication		
4.1.1	Bus Address	PROFIBUS address	126	1 to 126
4.1.2	Ident-Nr.	Selection of appropriate device database file (GSD)	Manufact.spec.	<ul style="list-style-type: none"> Profile spec. Manufact.spec.
4.2	Digit.Output ¹	Frequency or pulse signal for flow or alarm signal		
4.2.1	Function	Assignment of a function to digital output 1 'Split value active': the active output indicates a current flow value in the 0 to 'Split value' range (not effective for PROFIBUS).	Pulse	<ul style="list-style-type: none"> Pulse, Frequency, Alarm, Flow direction forw. Flow min, Flow max, Flow min/max, Total. forw. max, Total. rev. min, Total. net max, Total. net min Split value active, No function
4.2.2	Signal Type	Definition of signal logic for active event	Passive-pos.	<ul style="list-style-type: none"> Active-pos., 1, 2 Active-neg., 1, 2 Passive-pos. Passive-neg.
4.2.3	Pulse Rate Engr. Unit Pulse Rate	Number of pulses per unit of quantity (only effective with "Pulse" function) Engineering unit of quantity to which the number of pulses refers Number of pulses per unit of quantity	DN1...12: Imp/l >DN12: Imp/m ³ Depending on the nominal width 10Imp/l... 1Imp/m ³	<ul style="list-style-type: none"> pulses/l, m³, MI, ft³, Gal, MGal, ImpGal, Mimp• Gal, kg, t, lb, 0.01 ... 9999 pulses/unit
4.2.4	Pulse Width	(only with "Pulse" function)	+0.1 ms	0.1 ... 2000 ms
4.2.5	Fullsc. Freq	Frequency output at full scale flow value at digital output 1 (only effective for "Frequency" function)	10000 Hz	2 ... 10000 Hz

4.3	Digit.Output2 ¹			
4.3.1	Function	Assignment of a function to digital output 2 'Split value active': the active output indicates a current flow value in the 0 to 'Split value' range (not effective for PROFIBUS).	Alarm	<ul style="list-style-type: none"> • Alarm, Flow dir. forw., • Flow min, Flow max, Flow min/max, • Total. forw. max, • Total. rev. max, • Total. net max, • Total. net min, • Split value active, • No function
4.3.2	Signal type	Definition of signal logic for active event	Contact closes	<ul style="list-style-type: none"> • Contact closes • Contact opens
4.3	Digit.input ²			
4.3.1	Function	Assignment of a function to the input: Measured value=0: Measured value is set to 0 (affects all outputs and totalizers) Totalizer reset: reset+start	Measured value = 0	<ul style="list-style-type: none"> • Meas. val. = 0, • Total. forw. reset, • Total. rev. reset, • Total. net reset, • Total. all reset, • No function
4.3.2	Signal Type	Definition of signal logic	High-active	<ul style="list-style-type: none"> • High-active, • Low-active

1) Parameters apply only to devices with 20 mA/Hart communication and digital output 2 (7ME5034-0xxxx)

2) Parameters apply only to devices with 20 mA/Hart communication and digital input (7ME5034-2xxxx)

3) Parameters apply only to devices with PROFIBUS communication (7ME5034-1xxxx)

Identification

Table A- 5 Function group Identification parameters

5.1	Funct. Unit			
5.1.1	Tag	Tag number	(Customer-specific)	Text max.: <ul style="list-style-type: none"> • 32 characters 3 / • 8 characters 1,2
5.1.2	Descriptor	Tag descriptor	(Customer-specific) DN 2...12: l DN >12: m ³	Text max. <ul style="list-style-type: none"> • 32 characters 3 • 16 characters 1,2
5.1.3	Message	Tag message	(Customer-specific)	Text max. 32 characters
5.2	Manuf.Ident.			
5.2.1	Product type	Transmitter order number	(7ME5034-xxxx-xxA0)	
5.2.2	Serial number	Transmitter serial number	(N1xxxx-82xxxx)	
5.2.3	Software Rev.	Software version in the transmitter	(3.x.x)	

5.2.4	Device ID	Clear device identification; corresponds to HART long address	(Device-specific HART long address)	1 ... 99 999 (Can only be set with factory code by HART)
5.2.5	Manuf. Date	Transmitter manufacture date; form: DDMMYY	(Device-specific manufacture date)	DDMMYY (Can only be set with factory code by HART)
5.2.6	Sensor	Input only possible if no data can be read from SmartPLUG		
5.2.6.1	Nom.Diameter ⁵ Diameter	Inside nominal diameter of the sensor with probes: interior diameter of the surrounding tube	(Nominal width) 0.1 m	DN2 ... 2000 / 0.5 ... 80 in, probe (Only after 'Probe' is selected:) 0,1 ... 5 m
5.2.6.2	Product Type ⁴	Sensor order number	(7ME5034 -xxxxx-xxA0)	From SmartPLUG
5.2.6.2	Analog TRANSMAG ⁵	Select 'Yes' for measuring sensors with an R100 constant In this case, a CFH value must be entered in the 6.7.2 menu according to the following formula: CFH = 176,715 * DN2/R100, DN = nominal diameter in mm)	No	<ul style="list-style-type: none"> • No • Yes
5.2.6.3	Serial Number ⁴	Serial number of sensor	(Serial number)	From SmartPLUG

4) Parameters apply only to devices with 20 mA/Hart communication and digital output 2 (7ME504x-0xxxx)

5) Parameters apply only to devices with 20 mA/Hart communication and digital input (7ME504x-2xxxx)

Service

Table A- 6 Function group Service parameters

6.1	Enter Code	Input of code number agreed under "Customer Code" (menu 6.2) for releasing local parameterization	0	0 ... 9999 (according to setting under menu 6.2)
6.2	Customer Code	Selection of personal code: <ul style="list-style-type: none"> • Code 0: Parameters are not protected by a code. • Code >0: Parameters can only be changed after entering the code under "Enter Code" (menu 6.1) 	0	0 ... 9999
6.3	Service Code	Input of factory code for extended service functions	0	0 ... 99999
6.4	Reset	Device reset (without parameter changes)	Cancel	<ul style="list-style-type: none"> • Cancel • Reset
6.5	Control Values			
6.5.1	Volt. Um Volt. Uref	Control value for magnetic field current Control value for reference voltage		
6.5.2	Volt. Usig	Electrode differential voltage		

Parameters

6.5.3	Volt. Uel1	Control value for voltage between electrode 1 and medium		
6.5.4	Volt. Uel2	Control value for voltage between electrode 2 and medium		
6.5.5	Flow % Range 1,2	Actual flow in % of set full scale value		
6.5.6	Sampl. Freq.	Actual measuring frequency	(Approx. 2 x magnetic frequency)	
6.5.7	Selftest 0 % FS	Display of internal control values of measuring electronics. Run self-test to update (menu 2.4.1) Zero Gain	(Result display of the last self-test) (xxxxxxx) (Current status active/inactive)	Triggered when selecting menu 2.4.1
6.5.8	Service Info	Coded service information	(Info)	
6.5.9	Digital Input ²	Status of the digital input under consideration of the set signal type	(Actual status active/inactive)	
6.6	Zero Trim			
6.6.1	Zero Flow Cor.	Correction value for the zero point of the flow measurement in m/s	-1 ... +1 m/s	
6.6.2	Start Correct.	Start of zero calibration; The medium must be at a standstill during calibration!	Cancel	<ul style="list-style-type: none"> • Cancel • Start
6.7	Trim Parameter	Values in 6.7.2.4 can only be written if no SmartPlug data can be read		
6.7.1	Cal.factor	User-specific calibration factor; the measured flow value is multiplied by this factor before output (affects all outputs, totalizers and display)	1.0	0.5 ... 1.5
6.7.2	CFH ⁵ CFR ⁵	Calibration value for hydraulic reference point at 1m/s Calibration value for reference path	400 100	
6.7.3	ZPH ⁵	Calibration value for hydraulic zero point	0	

6.7.4	Excitat.Freq. ⁵	Magnetic current curve: <ul style="list-style-type: none"> • Bipolar PP f/5: Standard applications • Bipolar f/3: rapid applications • Unipolar f/6: Measuring sensors \leqDN150 up to year of construction 1995 	Bipolar PP	<ul style="list-style-type: none"> • PP f/5 • Bipolar f/3, • Unipolar f/6
6.7.5	EmptyTube Det. Act.Value EI ¹ Act.Value EI ² Threshold	Adjustment of electrode immersion check Display of actual control value of electrode EI1 in % of end value Display of actual control value of electrode EI12 in % of end value Threshold of diagnostic function "Immersion check" for "Tube empty" message (see menu 2.3)	 33 %	 5 ... 95 %

1) Parameters apply only to devices with 20 mA/Hart communication and digital output 2 (7ME5034-0xxxx)

2) Parameters apply only to devices with 20 mA/Hart communication and digital input (7ME5034-2xxxx)

5) Parameters apply only to devices with 20 mA/Hart communication and digital input (7ME504x-2xxxx)

B.1 PROFIBUS Communication

The following functions of the standard device (with 20 mA/HART interface) are not offered in the PROFIBUS version (7ME5034-1xxxx) because they are covered indirectly by the PROFIBUS function:

- Analog output (0/4 to 20mA)
- HART communication
- Digital output 2 (relay output)

Data transfer

The SITRANS F M TRANSMAG 2 has a PROFIBUS-PA connection compliant with IEC 1158 (synchronous transmission) which transfers data at a fixed speed of 31.25 kBit/s. The min. TSDR at startup is 11 bit times and can then be changed using the "Set_Prm" service. The bus address has the value 126 in the as-delivered state and can be changed either with the DP service "Set_Slave_Add" or on the local operating unit (menu 4.1.1).

Communication via PROFIBUS takes place with the EN50170 standard (PROFIBUS DP and DP V1).

The data traffic and the data formats are described in the following sections.

DP services

The following DP services are supported as slaves for a class 1 master:

- Data_Exchange
- Rd_Inp
- Rd_Outp
- Set_Prm
- Chk_Cfg
- Slave_Diag
- Set_Slave_Add
- Global_Control
- Get_Cfg

DP V1 services

The following DP V1 services are supported as slaves for a class 2 master DP V1 services supported as slaves:

- MSAC2_Initiate (Indication and Response)
- MSAC2_Abort (Request, Indication and Response)
- MSAC2_Read (Indication and Response)
- MSAC2_Write (Indication and Response)

B.2 Wiring devices with Profibus PA

 WARNING
Lid over terminals for power supply may not be removed! Use only certified measuring instruments!

The Profibus PA variant of the SITRANS F M TRANSMAG 2 differs from the HART variant with the 4-20 mA output in the bus interface and the omission of the digital output 2. The basic functions of the device including the operation and display remain basically the same.

The TRANSMAG 2 terminals 7 and 8 are reserved for the Profibus PA connection.

- 7: PA wire 1. This device is polarity independent
- 8: PA wire 2. This device is polarity independent

The PA interface is polarity independent, so the wires can be connected arbitrarily.

PA supports LINE, DROP, STAR topology and a combination of the three.

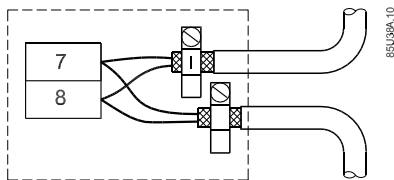

Figure B-1 PA wiring

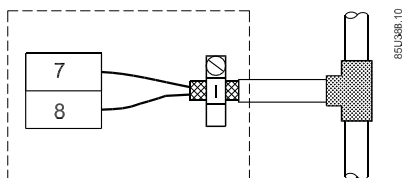

Figure B-2 PA wiring with T-connector

Shielding

- Only use shielded cables for the PROFIBUS connection. Any connection polarity is possible.
- The shield must be laid to cover all assigned terminal boxes, distributors up to the coupler or link.
- The shield must be connected and fixed with the shield clamp.
- To achieve the best EMC performance, the unshielded wires should be as short as possible, 3-4 cm.

Note

The specified immunity and radiated emission are only guaranteed if the bus shielding is fully effective. This includes connecting the shields to the metal connections of TRANSMAG 2, but also laying the shields to the terminal compartment, distributor, DP/PA coupler or DP/PA link.

Terminators

To ensure trouble-free communication, the PROFIBUS must have a bus terminator at both ends. This is usually already provided by the coupler or link at the control system end. An additional bus terminator must be fitted at the remote bus end.

B.3 Cyclic Data Traffic

Cyclic data transmission serves for fast exchange of process data between a Master class 1 (control system or PLC) and the slave (SITRANS F M).

Up to four different measured values (= modules) can be transmitted cyclically from the device to the control system as input data in one telegram with the "Data_Exchange" service.

The following measured values are available for selection in the given order:

1. Flow (volume or mass flow)
2. Totalizer (volume or mass) net
3. Totalizer (volume or mass) forwards
4. Totalizer (volume or mass) reverse

The output data are sent to the device with the cyclic request telegram. The number and type of actually transferred data can be determined with the aid of the configuration data (see Device Database File (GSD) (Page 103))

Acyclic data traffic

Acyclic data transmission is mainly used for remote control of devices, i.e. for transmitting parameters during commissioning, maintenance, batch processes or for displaying variables which are not included in the cyclic process data traffic.

Acyclic accesses can be carried out by Master class 1 (C1 connection) or Master class 2 (C2 connection). SITRANS F M supports up to 4 simultaneous C2 connections.

The more than 300 parameters including address (Slot and Index), format, value range, start value and attributes are stored in an object list "Obj80C4.rtf" which will be provided on request.

Note

Acyclic operation with SIMATIC PDM

We recommend using the SIMATIC PDM software package and a PC (compatible with industry standard) or a programming unit for acyclic operation.

B.4 Input Data (from Slave to Master)

Input data are process data (measured values) which are transmitted from the device to the master in the following format:

Every measured value consists of 5 bytes which are composed of a floating point value corresponding with IEEE - 754 (4 bytes) and the correspondent measured value status (1 byte). In the PROFIBUS telegram, the measured value is transmitted first and then the corresponding status.

Table B- 1 Measured value format

Byte No.	Bit							
	7 (MSB)	6	5	4	3	2	1	0 (LSB)
1	VZ	E 2 ⁷	E 2 ⁶	E 2 ⁵	E 2 ⁴	E 2 ³	E 2 ²	E 2 ¹
2	E 2 ⁰	M 2 ⁻¹	M 2 ⁻²	M 2 ⁻³	M 2 ⁻⁴	M 2 ⁻⁵	M 2 ⁻⁶	M 2 ⁻⁷
3	M 2 ⁻⁸	M 2 ⁻⁹	M 2 ⁻¹⁰	M 2 ⁻¹¹	M 2 ⁻¹²	M 2 ⁻¹³	M 2 ⁻¹⁴	M 2 ⁻¹⁵
4	M 2 ⁻⁹	M 2 ⁻⁹	M 2 ⁻⁹	M 2 ⁻⁹	M 2 ⁻⁹	M 2 ⁻⁹	M 2 ⁻⁹	M 2 ⁻⁹

VZ: sign: 0 positive, 1 negative E: Exponent M: Mantissa

B.5 Status bytes

Status bytes

The status bytes consist of three components:

- Quality (the MSBs 6 and 7):
Describes the basic quality of the corresponding measured value
- Substatus (bits 2 to 5):
Differentiates the quality of the corresponding measured value
- Limits (the LSBs 0 and 1):
Indicate exceeding of the limit value

Table B- 2 Status byte formats

Byte No.	Bit							
	7 (MSB)	6	5	4	3	2	1	0 (LSB)
5	Quality		Substatus				Limits	

These components may adopt the following values in SITRANS F:

Table B- 3 Formats of the quality bits

Bit 7	Bit 6	Profile Designation	Meaning
0	0	bad	Measured value cannot be used
0	1	uncertain	Measured value uncertain
1	0	good (not cascade)	Measured value OK

Table B- 4 Formats of the substatus bits

Bit 5	Bit 4	Bit 3	Bit 2	Profile Designation	Meaning
0	0	0	1	configuration error	Parameter error, i.e. upper and lower value for measuring or output scale identical
0	0	1	1	device failure	RAM or EEPROM defective; Diagnostic bit "Memory error" is also set and the diagnosis message "RAM error" or "EEPROM error" displayed locally
				sensor failure	Measurement was not possible; Diagnostic bit "Memory error" is also set and the diagnosis message "Measuring path fault" displayed locally
0	1	1	1	out of service	Corresponding function block is in "Out of service" mode (see parameter "MODE_BLK actual")

B.5 Status bytes

Bit 5	Bit 4	Bit 3	Bit 2	Profile Designation	Meaning
0	0	0	0	non specific	Measurement contains too many implausible measured values, e.g. due to solids or gas bubbles in the medium. Diagnostic bit "Memory error" is also set and the diagnosis message "RAM error" or "EEPROM error" displayed locally
0	0	0	1	last usable value	Failsafe mode: the current measured value has been replaced with the last good measured value
0	0	1	0	substitute set	Failsafe mode: the current measured value has been replaced with the agreed failsafe value
0	1	0	0	initial value	Failsafe mode or state before the first measurement: the current measured value has been replaced with the start value
0	1	0	0	sensor conversion not accurate	Measured value is outside the sensor limits (Table 5-1, Page 30)
				O.K.	Measured value is OK (normal state)
0	0	0	1	update event	A parameter with the "static" memory attribute has been changed locally or on the PROFIBUS
0	0	1	0	active advisory alarm	Upper warning limit value has been exceeded or the lower warning limit value has been undershot below
0	0	1	1	active critical alarm	Upper alarm limit value has been exceeded or the lower alarm limit value has been undershot

Table B- 5 Formats of the limit bits

Bit 1	Bit 0	Profile Designation	Meaning
0	0	O.K.	The measured value is within the limit values (normal state)
0	1	low limited	The measured value has exceeded the upper limit (alarm, warning or sensor limit)
1	0	high limited	The measured value has exceeded the upper limit value (alarm, warning or sensor limit)
1	1	constant	Measured value remains constant

Note

Limit bits can only be clearly evaluated in combination with the quality information!

Status byte combinations

The following combinations of the values of the status bytes described above are possible in normal operation (i.e. when the input value of the function block concerned incl. status is not simulated):

Table B- 6 Valid combinations of the status byte

Value hex	Meaning substatus		applies to				
	quality		limits	flow	total net	total	total
1F	bad	out of service	constant	X			
0F	bad	device failure	constant	X			
0C	bad	device failure	O.K.		X	X	X
11	bad	sensor not connected	constant		X	X	X
07	bad	configuration error	constant	X	X	X	X
00	bad	non specific	O.K.	X	X	X	X
52	uncertain	sensor conversion not accurate	high limited	X	X	X	X
51	uncertain	sensor conversion not accurate	low limited	X	X	X	X
4F	uncertain	initial value	constant	X			
4B	uncertain	substitute set	constant	X			
47	uncertain	last usable value	constant	X			
8E	good	active critical alarm	High limited	X	X	X	X
8D	good	active critical alarm	low limited	X	X	X	X
8A	good	active advisory alarm	high limited	X	X	X	X
89	good	active advisory alarm	low limited	X	X	X	X
84	good	active update event	O.K.	X	X	X	X
80	good	O.K.	O.K.	X	X	X	X

Note

The status conditions have decreasing priority from top to bottom. If several status conditions are fulfilled, the current status with the highest priority will be signaled.

B.6 Output Data (from Master to Slave)

The output data consist per totalizer (net, forwards and reverse) of one byte of which only the two LSBs respectively are evaluated. All other bits are not evaluated but should be set to 0 for safety. This value represents the "SET_TOT" parameter of the "Totalizer Function Block" defined in the PROFIBUS-PA profile.

Table B- 7 Totalizer mode "SET_TOT"

Bit 1	Bit 0	Profile description	Meaning
0	0	cancel	totalizer is running
0	1	reset	totalizer is stopped and reset to 0
1	0	preset	Totalizer is stopped and reset to a preset value (PRESET_TOT parameter, only acyclic access)

The transferred value is effective until it is changed, i.e. after the value 1 (reset totalizer) is sent, for example, the totalizer will remain on the value 0 until the SET_TOT parameter is changed again.

Each SET_TOT value affects the corresponding totalizer independently of the others. The quantities are also cumulated independently of each other, i.e. the net quantity does not have to be equal to the sum of the quantity forwards and quantity reverse especially if a totalizer has been reset or was preset.

B.7 Diagnostics

The diagnostic data can be requested with the "Slave_Diag" service.

If extended diagnostic messages (Ext_Diag_Data) exist, this is displayed by the "Diag_Flag" of the "Data_Exchange" service. If the master then calls the "Slave_Diag" service, the external diagnostic data are supplied in the following form by the device:

Table B- 8 Format of diagnostic data

Byte No.	Profile designation	Value	Meaning
1	Header	8 (dec.)	(fixed) length of diagnostic data (number of bytes)
2		254 (dec.)	(fixed)
3		1	(fixed)
4		0 or 1	Display of changes in diagnostic data (see below)
5	Diagnosis	Byte 1	(s. below) Diagnostic information
6		Byte 2	-- (not supported)
7		Byte 3	-- (reserved)
8		Byte 4	(s. below) Note on additional diagnostic data

The total length of the external diagnostic data is always 8 including the header.

The "Diag_Flag" is always set when something has changed in the last four bytes of the diagnostic data (corresponds to the parameter "DIAGNOSIS") since the last message, i.e. even when diagnostic messages disappear again so that the master can register every change in the diagnostic data.

When a diagnostic message is active, the corresponding bit is set otherwise reset.

The following bits of the external diagnostic data are supported by SITRANS F M (all other bits stay reset at all times):

Table B- 9 Format of the diagnostic data, byte 4

Bit No.	Description	Meaning
0	Error appears	At least one bit of the following 4 bytes (DIAGNOSIS) was set
1	Reset	At least one bit of the following 4 bytes (DIAGNOSIS) was reset
2 ... 7	Reserved	---

The "Error appears" message has priority over the "Error disappears" message, i.e. if one diagnostic bit is set and another reset simultaneously, "Error appears" is reported.

The DIAGNOSIS part contains diagnostic messages of the device and has the following structure (Bit 0 = LSB, Bit 7 = MSB):

Table B- 10 Format of the diagnostic data, Byte 5 (=DIAGNOSIS Byte 1)

Bit No.	Description	Meaning	Cause (local message)
0	DIA_HW_ELETR	Hardware failure of the electronic	"Com.--Module failure" Communications module cannot be addressed Sensor failure (sensor failure) "Measurement module failure"
4	DIA_MEM_CHKSUM	Memory error	Memory failure"
5	DIA_MEASUREMENT	Measurement failure	Flow measurement failure" "Tube empty" "Measuring range overflow"

Table B- 11 Format of diagnostic data, Byte 8 (=DIAGNOSIS Byte 4)

Bit No.	Description	Meaning	Cause (local message)
0 ... 6	reserved	---	
7	EXTENSION_AVAILABLE	More diagnosis information is available	More diagnosis information available (here: Local messages see DIAGNOSIS--Byte 1)

The bits in DIAGNOSIS usually take over the function of a group message which can then be split up in detail using the local messages.

The EXTENSION_AVAILABLE bits indicates that other diagnostic information is available, basically details of the DIAGNOSIS message. This information is displayed locally.

Additionally, the measured value-related messages are transmitted cyclically with the measured values in the status byte (Substatus).

Examples for telegrams with diagnostic data (Ext_Diag_Data)

All diagnostic bits are reset in the initial state. When the "Tube empty" event occurs (byte 5, bit 5 set), this gives the following diagnostic data:

Diagnosis Byte No.	1	2	3	4	5	6	7	8
Value (hex)	08	FE	01	01	20	00	00	80
Meaning	Header				Diagnosis			

Initial state: all diagnostic bits are reset. With the occurrence of the events "Memory failure" (byte 5, bit4) and "Flow outside sensor limits" (byte 5, bit 5), this gives the following diagnostic data:

Diagnosis Byte No.	1	2	3	4	5	6	7	8
Value (hex)	08	FE	01	01	30	00	00	80
Meaning	Header				Diagnosis			

Initial state: at least one diagnostic bit is set. As soon as all diagnostic messages are reset, the following diagnostic data result:

Diagnosis Byte No.	1	2	3	4	5	6	7	8
Value (hex)	08	FE	01	02	00	00	00	80
Meaning	Header				Diagnosis			

B.8 Write Protection

General write protection can be enabled with the WRITE_LOCKING PROFIBUS parameter. This will then prevent any changes being made to parameters locally or using PROFIBUS.

- 0: General write protection enabled: Parameters cannot be edited. Exception: Output data for totalizers (set, start) when they are transmitted cyclically (with the data exchange service).
This write protection can be disabled locally by entering the code "2457" (menu 6.1), when there is a continued communication failure.
- >0: General write protection disabled

Note

Parameter consistency between the device and control system is decisive for the correct interpretation of the cyclical measured values. During operation the local write protection (menu 6.2) or WRITE_LOCKING should therefore be enabled.

Hardware Write Protection

If write protection with hardware components is not set, the HW_WRITE_PROTECTION PROFIBUS parameter will not be of any significance.

Calibration data

Access to calibration data and special service parameters can only be enabled by entering a factory code. Improper changes to these data can cause the device to seriously malfunction.

Locking local operation

Local operation can be locked using the LOCAL_OP_ENABLE PROFIBUS parameter:

- 0: Local operation is disabled completely and the last valid display status remains. If communication fails for longer than 30 s, the local lock will be disabled automatically until communication is restored.
- 1: Local operation is enabled and if necessary limited with the WRITE_LOCKING write protection or a customer code.

B.9 Device Database File (GSD)

The device database file (GSD) is used to configure the format and order of the cyclic data. The acyclic parameter "IDENT_NUMBER_SELECTOR" must be set to select the GSD (0 = profile GSD, 1 = manufacturer-specific GSD = factory setting). This can also be done on the local operating unit under menu item 4.1.2.

The GSD lists all permissible identifiers for every measured value (= module). They can be freely combined with the restriction that only one identifier may be used per module and the order of the identifiers must be the same as the order of modules. At least one measured value must be requested, i.e. the number of identifiers must be at least 1 and 4 at the most.

The formats "resettable quantity" and "quantity" are accepted for the totalizer modules. The identifiers are checked independently of each other, i.e. when polling several measured values, combinations with different formats are permissible.

The order of measured values specified in the GSD is defined in the cyclic telegram and cannot be changed (see also section 5.4.1). If one of the four measured values is omitted, "Free Place" must be specified as an identifier.

Rules are stored in the GSD for use in the "SIMATIC S7/HW-Config" control system which prevent wrong configuration.

Note

As an alternative to the device-specific GSD, standard GSD for magnetic-inductive flow transmitters described in profile 3.0 can also be used, but does not support the manufacturer-specific extensions.

Example

The measured values "Totalizer net" and "Totalizer forwards" should be transmitted. Then the following identifier combination must be specified:

- Free Place (for flow)
- long Identifier (for totalizer net)
- long Identifier (for totalizer forwards)

No identifier for the totalizer reverse is necessary here because the value of the totalizer forwards is the last measured value to be transmitted.

The following files (GSD and bitmap) can be downloaded from the internet using the address http://www.ad.siemens.de/csi_e/gsd

These files are also implemented in the device install files for SIMATIC PDM software.

GSD files (version 31.07.2001)

```
#Profibus_DP
GSD_Revision = 3
Vendor_Name = "SIEMENS AG"
Model_Name = "SITRANS FM"
Revision = "Revision 01"
Ident_Number = 0x80C4
Protocol_Ident = 0
Station_Type = 0
FMS_supp = 0
Hardware_Release = "A01"
Software_Release = "Z01"
Bitmap_Device = "SIE80C4n"
31.25_supp = 1
45.45_supp = 1
93.75_supp = 1
MaxTsd_r_31.25 = 100
MaxTsd_r_45.45 = 250
MaxTsd_r_93.75 = 1000
Redundancy = 0
Repeater_Ctrl_Sig = 0
24V_Pins = 0
Freeze_Mode_supp = 0
Sync_Mode_supp = 0
Auto_Baud_supp = 0
Set_Slave_Add_supp = 1
Min_Slave_Intervall = 200
Modular_Station = 1
Max_Module = 4
Max_Input_Len = 20
Max_Output_Len = 3
```

```
Max_Data_Len = 23
Fail_Safe = 0
Slave_Family = 12
Max_Diag_Data_Len = 20
;----- Description of device related diagnosis: -----
;
Unit_Diag_Bit(16) = "Error appears"
Unit_Diag_Bit(17) = "Error disappears"
Unit_Diag_Bit(24) = "Hardware failure electronics"
Unit_Diag_Bit(25) = "Hardware failure mechanics"
Unit_Diag_Bit(26) = "Motor temperature too high"
Unit_Diag_Bit(27) = "Electronic temperature too high"
Unit_Diag_Bit(28) = "Memory error"
Unit_Diag_Bit(29) = "Measurement failure"
Unit_Diag_Bit(30) = "Device not initialized"
Unit_Diag_Bit(31) = "Device initialization failed"
Unit_Diag_Bit(32) = "Zero point error"
Unit_Diag_Bit(33) = "Power supply failed"
Unit_Diag_Bit(34) = "Configuration invalid"
Unit_Diag_Bit(35) = "Restart"
Unit_Diag_Bit(36) = "Coldstart"
Unit_Diag_Bit(37) = "Maintenance required"
Unit_Diag_Bit(38) = "Characteristics invalid"
Unit_Diag_Bit(39) = "Ident_Number violation"
Unit_Diag_Bit(55) = "Extension Available"
User_Prm_Data_Len = 0
;===== Description of modules =====
;
; Use always the module order specified in this file.
; Use exactly one identifier per module.
; If you don_t want to get the measuring value of a certain module ; from the device with the
input data, use Free place for this module ; instead of another identifier.
;
; For the module 1 you have the choice between these different ; identifiers:
;
; - Free Place
; - Short identifier format (identifier byte)
```

```
; - Long identifier format (extended identifier)
;
; For the modules 2, 3 and 4 you have the choice between these ; different identifiers:
;
; - Free Place
; - Long identifier format (extended identifier)
; - Long identifier format, resettable (extended identifier)

; With the "resettable" format it is possible to reset the totalizer,
; transmitting suitable output data to the device.
;-----
; Free place - usable for each module instead of another identifier
;-----
Module = "Free place" 0x00
0
EndModule
;-----
; Module 1 - Flow
;-----
Module = "Flow" 0x94
1
EndModule
;-----
; Module 2 - Quantity net
;-----
Module = "Quantity net" 0x41, 0x84, 0x85
2
EndModule
Module = "Resettable quantity net" 0xC1, 0x80, 0x84, 0x85
3
EndModule
;-----
; Module 3 - Quantity forward
;-----
Module = "Quantity forward" 0x41, 0x84, 0x85
4
```

```
EndModule
Module = "Resettable quant. forw." 0xC1, 0x80, 0x84, 0x85
5
EndModule
;-----
; Module 4 - Quantity reverse
;-----
Module = "Quantity reverse" 0x41, 0x84, 0x85
6
EndModule
Module = "Resettable quant. rev." 0xC1, 0x80, 0x84, 0x85
7
EndModule
;-----
;SlotDefinition
;-----
SlotDefinition
Slot(1) = "Flow" 1 0,1 ;Default am zykl. Verkehr
Slot(2) = "Quantity net" 2 0,2,3 ;Default am zykl. Verkehr
Slot(3) = "Quantity forward" 0 0,4,5 ;Default nicht am zykl. Verkehr
Slot(4) = "Quantity reverse" 0 0,6,7 ; Default nicht am zykl. Verkehr EndSlotDefinition
```

B.10 Literature list

- /1/ PROFIBUS: Brief Technical Description
- /2/ PROFIBUS PA - Profiles for Process Control Devices General Requirements V 3.0
- /3/ PROFIBUS PA - Profiles for Process Control Devices Data Sheet Transmitter V 3.0

See also

Further information on Profibus can be found on the Website of the Profibus organisation:

<http://www.profibus.com> (<http://www.profibus.com/pall/meta/downloads/>)

Various material, including technical descriptions, can be downloaded here:

<http://www.profibus.com/download.html> (<http://www.profibus.com/>)

GSD: Device database file

LSB: Least significant Bit

MSB: Most Significant Bit

PDM: Process Device Manager

PNO: PROFIBUS user organization

PROFIBUS PA: Process Fieldbus for Process Automation

Appendix

C.1 Certificates

Certificates are posted on the Internet and on the documentation CD-ROM shipped with the device.

C.2 Ordering

In order to ensure that the ordering data you are using is not outdated, the latest ordering data is always available on the Internet: Process instrumentation catalog (<http://www.siemens.com/processinstrumentation/catalogs>)

Index

A

- Acyclic data transmission, 97
- Analog output, 50
- Analog Output, 40
- Applications, 11

B

- Bus communication solutions, 13

C

- Cable specifications, 24
 - Remote version, 29
- Calibration factor, 61
- Cleaning, 63
- Commissioning, 31
- Commissioning
 - Safety, 31
- Compliance, (See Laws and directives)
- Contact person, 8
- Control values, 60
- Current limiting, 50
- Customer code, 59
- Customer Support Hotline, 65
- Cyclic data transmission, 97

D

- Decontamination, 65
- Density, 45
- Design, 77
- Device database file (GSD), (See Device database file (GSD))
- Device status, 40
- Device test, 42
- Digital input, 57
- Digital output 1, 54
- Digital output 2, 55
- Dimensions, 78
- Direction
 - Flow, 45
 - Measurement, 45
- Display, 39

E

- Electrical connection
 - Cable specifications, 24
 - Connection diagram, 25
 - HART, 26
 - Power supply, 25
 - Profibus, 96
 - Remote version, 27
 - Resistance check, 67
 - Safety, 23
 - Signal cables, 26
- Electrode check, 41
- Electrode circuit, 67
- EMC performance, 97
- Empty Pipe Detection, 42
- Engineering unit, 35, 43
- Enter Code, 59
- Error messages, 41, 70

F

- Failure signal, 51
- Features, 12
- Filter time constant, 46
- Flow, 39
- Flow profile, 15
- Flow Upper Range Value, 43
- Flow velocity, 40
- Frequency, 40
- Function group
 - Analog output, 50
 - Device outputs, 88
 - Diagnostics, 40, 84
 - Display, 83
 - Flow, 43
 - Identification, 58, 90
 - Measuring functions, 86
 - Service, 59, 91
- Function Group
 - Display, 39
- Fuses
 - Change of, 63

- G**
 - Grounding rings, 19
 - GSD, 105

- H**
 - HART, 13
 - System integration, 33
 - Hotline, 65
 - Hysteresis, 44, 45

- I**
 - Illumination, 35
 - Immersion check, 61
 - Inlet/outlet, 16
 - Input, 75
 - Installation
 - Inlet/outlet, 16
 - Pipe mounting, 22
 - Prerequisites, 15
 - Sensor location, 17
 - Standard mounting plate, 21
 - Transmitter, 21
 - Vertical/horizontal, 16
 - Internet
 - Contact person, 8, 65
 - Flowdocumentation, 8
 - Support, 65
 - Introduction, 7
 - Items supplied, 7

- L**
 - Language, 35
 - Laws and directives, 9
 - Limits, 44
 - Line cross sections, 18
 - Local display, 32, 77
 - Turn, 20
 - Low flow cut-off, 46

- M**
 - Maintenance, 63
 - Manufacturer data, 59
 - Measuring accuracy, 76
 - Media
 - Abrasive, 15
 - Allowed types, 15
 - Menu structure, 39
 - Multi display, 39

- N**
 - Noise Suppress, 47
 - Nominal width, 59

- O**
 - Operating conditions, 77
 - Operating principle, 11, 15
 - Operation, 32
 - Mode, 75
 - Operating examples, 35
 - Via bus communication, 33
 - Via local display, 32
 - Orifice protectors
 - Protective rings, 15
 - Output, 75
 - Output data, 102

- P**
 - Parameters, (See Function group)
 - Pipe reductions, 18
 - Pipes
 - Electrically conductive, 19
 - Electrically isolated, 19
 - Potential equalization, 19
 - Power supply, 78
 - Profibus, 95
 - Bus address, 53
 - Data transfer, 95
 - Data transfer (acyclic), 97
 - Data transfer (cyclic), 97
 - Diagnostics, 102
 - Electrical connection, 96
 - GSD, 53
 - Identity number, 53
 - Input data, 98
 - Menu item 4.1, 52
 - System integration, 34
 - Profibus PA, 13
 - Protection degree, 15
 - Protective rings, 15
 - Pulse rate, 36, 55
 - Pulse width, 55

R

Recalibration, 64
Reference conditions, 76
Reference potential, (See Potential equalization)
Reset, 60
Resistance, 67
Return procedures, 65

S

safety
 instrument safety standards, 9
Safety notes, 9
Sensor (911/E), 11
Sensor location, 17
Service, 65
 Application information, 71
Service code, 60
SIMATIC PDM, 34
Simulation flow, 42
Simulation outputs, 42
Slurry mode, 47
SmartPLUG, 12, 31
Split mode, 51
Status byte combinations, 101
Status bytes, 99
Support, 65

T

Tag data, 31, 58
Technical data, 75
Temperature
 Ambient and medium, 15
Totalizer forwards, 48
Totalizer mode "SET_TOT", 102
Totalizer net, 49
Totalizer reverse, 49
Totalizers, 40
Troubleshooting, 67, 68

U

URV, (See Flow Upper Range Value)

W

Wall mounting, 21
Wiring, (See Electrical connection)
Write protection, 34

Z

Zero flow correction, 60
Zero Trim, 60

For more information

www.siemens.com/flow

Siemens A/S
Flow Instruments
Nordborgvej 81
DK-6430 Nordborg

Subject to change without prior notice
Order No.: A5E00102775
Lit. No.: A5E00102775-08
© Siemens AG 12.2010



www.siemens.com/processautomation