

**Model 101** – For use with all SC1000, SC2000 & SC3000 Reels

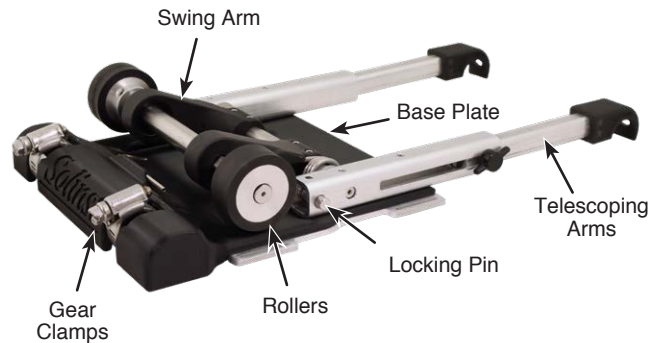
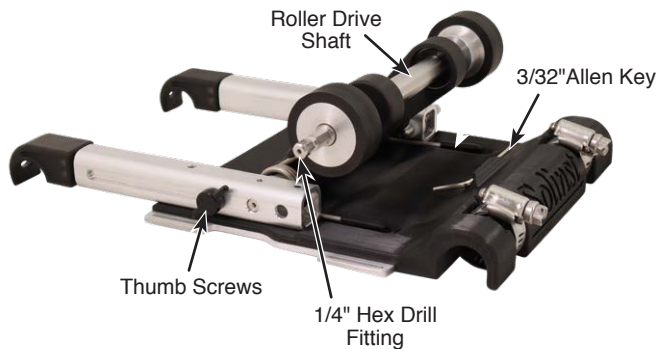

*Solinst Model 101 Power Winder (#116159)*

## Installation Instructions

1. Use a large flathead screwdriver or 8 mm (5/16") wrench/socket to loosen the two gear clamps. (When you first receive the Power Winder, the gear clamps will be loosened.)



2. Be mindful of the potential pinch-points of the swing arm motion. Use the 'heel' of your hand to push firmly down on the roller drive Shaft until it reaches the base plate. Push the Locking Pin into the hole on the Swing Arm. This will hold the spring-loaded swing arm in place. Ensure the pin is pushed in all the way. This will hold the rollers out of the way while installing on an SC1000 (small) reel.

**Note:** If installing on an SC2000 (medium) or SC3000 (large) Solinst reel, step 2 may not be required, as there is enough space between the frame and hub to easily fit the Power Winder.

3. Place the reel on its side with the faceplate up.
4. Slide the Power Winder base onto the left leg of the reel frame, with the rollers towards the hub. Ensure the base of the Power Winder is pushed all the way back on the left leg of the reel until it stops.



5. With the reel still on its side, tighten the gear clamps to secure the Power Winder to the reel. This ensures the Power Winder is tight against end of leg and the rollers are aligned with the reel.
6. If not already, loosen the black thumb screws on the telescoping arms of the Power Winder, and adjust them to the appropriate length so they fit over the legs of the reel frame. Tighten the thumbscrews to hold the arms in place.



...continued on page 2

7. Push down on the roller drive shaft to release the locking pin. The swing arm will pop up and the rollers will engage against the edges of the reel's faceplate and backplate.



**Notes:** The 3/32" Allen key supplied on the Power Winder can be used to loosen the two rollers so you can adjust them to fit different width reel hubs. Slide them into the correct positions, then tighten into place.

The ends of the roller drive shaft is D-shaped for one set screw to tighten onto the flat portion of the "D" and the other set screw will tighten into the round portion of the shaft.

The rollers can also rotate 180° to suit other reel types. The rollers can also be installed to face inwards to suit narrower reels (keep a minimum spacing of 3/32" to avoid roller wearing against swing arm).



## Operating Instructions

1. A power drill/driver is used to connect to the standard 1/4" hex fitting on the roller drive shaft of the Power Winder. Follow the directions specific to your drill/driver for attachment to the hex fitting.

**Note:** It is recommended to use a drill/driver with a minimum of 12V, however 18V is preferred.



2. Ensure to adjust the drill to an appropriate speed.

**Note:** Setting your drill to a slower speed can allow more precise measurements of product layers or temperature or conductivity interfaces when using instruments such as the Solinst Model 122 Interface Meter or Model 107 TLC Meter.

3. Position the reel as required for your specific measurement application. **Ensure the brake is not applied to the reel.**

**Note:** It is recommended to place medium and large reels on the ground, or on a sturdy surface like a Solinst Field Table. When using small reels, there is the option to hang the reel using the Tape Guide, or using optional straps available from Solinst to secure the Power Winder and reel directly to a well casing.

4. With the drill set in "reverse", slowly start the drill, which will engage the rollers and start the reel turning, unwinding and lowering the tape/cable/tubing on the reel. You may need to engage the brake against the reel to slow the winding speed.
5. Once at depth, stop the drill and operate the Water Level Meter or other connected instrument as described in their separate instructions to obtain the desired measurement or sample.

**Note:** When using a Water Level Meter or Tag Line, ensure you slow the drill/winding as the probe/tag nears the surface, so as to not get hit with the probe/tag as it exits the well.

6. When ready, switch the drill to the "forward" position and start the drill (if at depths >200 m (650 ft) start the drill at a slower speed and increase as you wind). This will turn the reel in the opposite direction to wind the tape/cable/ or tubing back up. Note: you can use your free hand to properly guide the tape back onto the reel.
7. Once finished, stop the drill and remove it from the Power Winder Fitting.

...continued on page 3

### Using the Optional Flex Drill Adaptor (#116199)

For easier access to the 1/4" hex fitting on the Power Winder, a Flex Drill Adaptor is available so you can operate the Power Winder using your drill/driver at any angle.



1. To connect the Adaptor, push the collar fitting forward and slide onto the Power Winder hex fitting and release.
2. Connect your drill/driver to 1/4" hex fitting on the other end of the Adaptor, and operate as described in the previous section. Remove the drill from the Adaptor when finished.
3. To remove the Adaptor, pull the collar fitting back and slide off the hex fitting on the Power Winder.



### Power Winder Periodic Maintenance

The 3/32" Allen key that is supplied with the Power Winder should be used to tighten all of the fasteners on the Power Winder that could become loose over time. This includes the set screws in the rollers, the four set screws on the swing arm and the fasteners on the base of the Power Winder. No lubrication is used, anywhere.

### Using the Optional Cinch Straps (#116059)

A set of cinch straps is available for adding to the base of the Power Winder, to allow you to secure the Power Winder to a well casing or for use in another application.



1. To connect the cinch straps, thread them through the base of the Power Winder as shown in the photo above.
2. To use the straps, insert the end of the strap into the backside of the buckle and push it through the buckle lever. Pull the strap to tighten it.
3. To release the straps, push down on the lever of the buckle and pull the strap through.