

Moisture

 Panametrics

DewPro[®] MMR30

Installation & Operation Manual



Moisture



DewPro[®] MMR30

General Eastern Mid-Range Moisture Transmitter

Installation & Operation Manual

A40251524 Rev.B
July 2020

panametrics.com

Copyright 2020 Baker Hughes company.

This material contains one or more registered trademarks of Baker Hughes Company and its subsidiaries in one or more countries. All third-party product and company names are trademarks of their respective holders.

[no content intended for this page]

Information Paragraphs

Note: *These paragraphs provide information that provides a deeper understanding of the situation, but is not essential to the proper completion of the instructions.*

IMPORTANT: These paragraphs provide information that emphasizes instructions that are essential to proper setup of the equipment. Failure to follow these instructions carefully may cause unreliable performance.



CAUTION! This symbol indicates a risk of potential minor personal injury and/or severe damage to the equipment, unless these instructions are followed carefully.



WARNING! This symbol indicates a risk of potential serious personal injury, unless these instructions are followed carefully.

Safety Issues



WARNING! It is the responsibility of the user to make sure all local, county, state and national codes, regulations, rules and laws related to safety and safe operating conditions are met for each installation. The safety of any system incorporating the equipment is the responsibility of the assembler of the system.

Auxiliary Equipment

Local Safety Standards

The user must make sure that he operates all auxiliary equipment in accordance with local codes, standards, regulations, or laws applicable to safety.

Working Area



WARNING! Auxiliary equipment may have both manual and automatic modes of operation. As equipment can move suddenly and without warning, do not enter the work cell of this equipment during automatic operation, and do not enter the work envelope of this equipment during manual operation. If you do, serious injury can result.



WARNING! Make sure that power to the auxiliary equipment is turned OFF and locked out before you perform maintenance procedures on the equipment.



WARNING! It is the responsibility of the user to make sure the PWR, Hart, Modbus and I/O cable can meet the cable specification, which is described in Appendix A.

Qualification of Personnel

Make sure that all personnel have manufacturer-approved training applicable to the auxiliary equipment.

Personal Safety Equipment

Make sure that operators and maintenance personnel have all safety equipment applicable to the auxiliary equipment. Examples include safety glasses, protective headgear, safety shoes, etc.

Unauthorized Operation

Make sure that unauthorized personnel cannot gain access to the operation of the equipment.

Environmental Compliance

Waste Electrical and Electronic Equipment (WEEE) Directive

Panametrics Measurement & Control is an active participant in Europe's *Waste Electrical and Electronic Equipment (WEEE)* take-back initiative, directive 2012/19/EU.



The equipment that you bought has required the extraction and use of natural resources for its production. It may contain hazardous substances that could impact health and the environment.

In order to avoid the dissemination of those substances in our environment and to diminish the pressure on the natural resources, we encourage you to use the appropriate take-back systems. Those systems will reuse or recycle most of the materials of your end life equipment in a sound way.

The crossed-out wheeled bin symbol invites you to use those systems.

If you need more information on the collection, reuse and recycling systems, please contact your local or regional waste administration.

Visit <https://www.gemeasurement.com/environmental-health-safety-ehs> for take-back instructions and more information about this initiative.

Chapter 1. General System Information

1.1 Unpacking and Inspection1
 1.2 Introduction 2
 1.3 Theory of Operation 3
 1.4 Dimensions 4

Chapter 2. Installation Guidelines

2.1 General Hints 5
 2.2 Method I - Orifice at Outlet 6
 2.3 Method II - Orifice at Inlet 7
 2.4 Method III - No Flow Restriction 8
 2.5 Method IV - Remote Installation 9

Chapter 3. Wiring Instructions

3.1 Wiring, General Guidelines 11
 3.2 System Configuration 11
 3.3 Mounting in Normal Environments 12
 3.4 Mounting in Environments with Severe Electrical Noise 12
 3.5 Electrical Connection 13
 3.6 General Instructions 13

Chapter 4. Optional Display/User Interface

4.1 Installation 15
 4.2 Description of the DewPro MMR30 Programming Matrix 16
 4.3 Special Functions of the Push Buttons 18
 4.4 Functions of the Matrix 19

Chapter 5. Troubleshooting

5.1 Problems and Recommended Solutions 27
 5.2 Removing the Filter 27

Chapter 6. Technical Specifications

6.1 MMR30 Specifications 29
 6.2 Optional Onboard Display with User Interface 30
 6.3 EMI/RFI 30
 6.4 EMC 30

Chapter 7. Accessories

Appendix A. Matrix Table for Programming

Chapter 1. General System Information

1.1 Unpacking and Inspection

Upon receipt of the DewPro MMR30, examine the shipping carton for broken or open packing, distortion, or any other evidence of mishandling. If inspection indicates damage to the unit or any of its components, notify the carrier (within 15 days of delivery) and request an inspection.

1.1.1 Unpacking

Move the carton to a clean work area and unpack. The carton you receive should contain:

- DewPro MMR30
- Installation and Operation Manual
- Calibration certificate

1.1.2 Checking the Model Number

Compare the model number (on the product label) with the product structure (see Figure 1 below) to ensure you have received everything you ordered.



Figure 1: Sample MMR30 Product Label with Model Number

Product Structure MMR30

1. Certification/Approvals:
 - R Standard (not certified)
 - S Other
2. Process Connection:
 - 1 ½" MNPT (1/4" tube fitting if B, C or D is selected below)
 - 2 G ½ (6 mm tube fitting if B, C or D is selected below)
 - S Other
3. Orifice Configuration:
 - A Inlet: None; Outlet: Orifice, with ¼" FNPT connection

- B Inlet: None; Outlet: Orifice, with (6 mm) ¼" tube fitting installed
 - C Inlet: None; Outlet: None, with (6 mm) ¼" tube fitting installed
 - D Inlet: Orifice; Outlet: None, with (6 mm) ¼" tube fitting installed
 - S Other
4. Enclosure Conduit:
- 1 Enclosure conduit M20X 1.5-F with cable gland and plug
 - 2 Enclosure conduit M20X 1.5-F with 1/2" NPT-F adapter and plug
 - S Other
5. Output Configuration/Dewpoint Range:
- A Td -15°C to +10°C (+5°F to +185°F), no display, error 22 mA
 - C As A, fault status: hold
 - D As A, fault status: 3.6 mA
 - G As A, with integral display, user interface
 - S Other

1.2 Introduction

1.2.1 Unit Description

The DewPro MMR30 (shown in Figure 2 below) is a loop powered mid-range moisture transmitter. The transmitter includes a sensor element, a flow chamber, a weatherproof enclosure, microprocessor electronics, and assorted fittings, all in a compact assembly. In most cases, either the inlet or outlet port includes an orifice to regulate the flow. The placement of this orifice determines whether the dew point measurement is done at process (line) pressure (outlet orifice), or at atmospheric pressure (inlet orifice).

1.2.2 Optional Display/User Interface

The optional display/user interface feature allows the DewPro to be configured to the user's specifications. See Chapter 4 for more information.

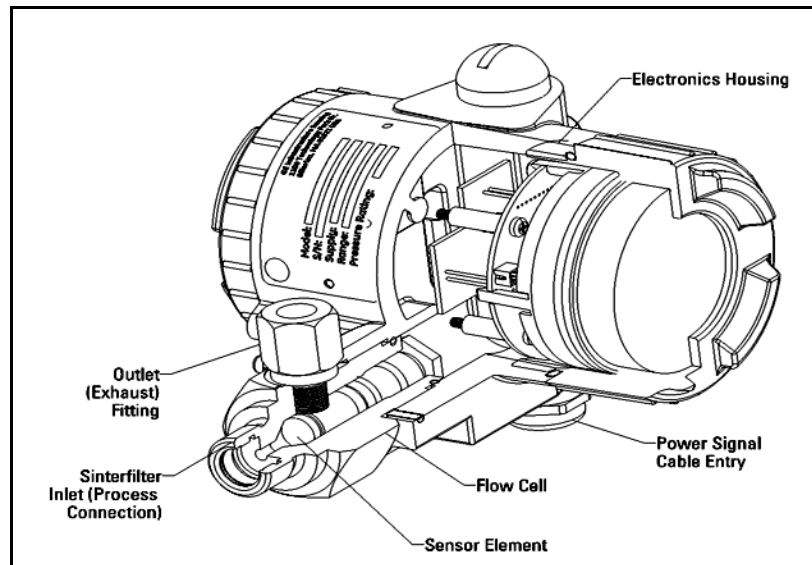

Figure 2: The DewPro MMR30

1.3 Theory of Operation

1.3.1 4 to 20 mA Loop

The DewPro MMR30 microprocessor controlled electronics operate with a DC voltage supply from 12 to 28 VDC. At the nominal 24 VDC supply, the maximum loop resistance is 600 Ohm. The signal is represented by the 4 to 20 mA loop current and is directly proportional to the dewpoint range in °C or °F. In the standard range, 4 mA corresponds to -15°C (+ 5°F) and 20 mA to +85°C (+185°F) dew point temperature.

1.3.2 Bypass

In dryer applications, the moisture sensor performs best when mounted in a bypass. The built-in bypass of the DewPro eliminates costly hardware associated with traditional sampling methods. The DewPro installs easily into the process with its G ½ or ½" NPT-M threaded connection.

1.3.3 Polymer Sensor

The sensing element in the MMR30 is a silicon-based polymer that uses the capacitance principle for the moisture measurement. The IC chip includes the moisture sensor and appropriate integrated circuitry. A platinum RTD temperature sensor is built in to provide temperature compensation for maximum accuracy. The sensor element is protected from condensation using a hydrophobic sintered filter.

1.3.4 Calibration

Each DewPro is factory calibrated against precise NIST certified moisture references and has an accuracy of ±1°C dew point for dew points above 0°C. Field calibration is possible with the use of a moisture generator. Consult the factory for details.

1.4 Dimensions

Choose a mounting location which allows enough clearance for the use of tools. Figure 3 below shows installation dimensions for a standard DewPro, while Figure 4 below shows the dimensions for a DewPro with the optional display/user interface.

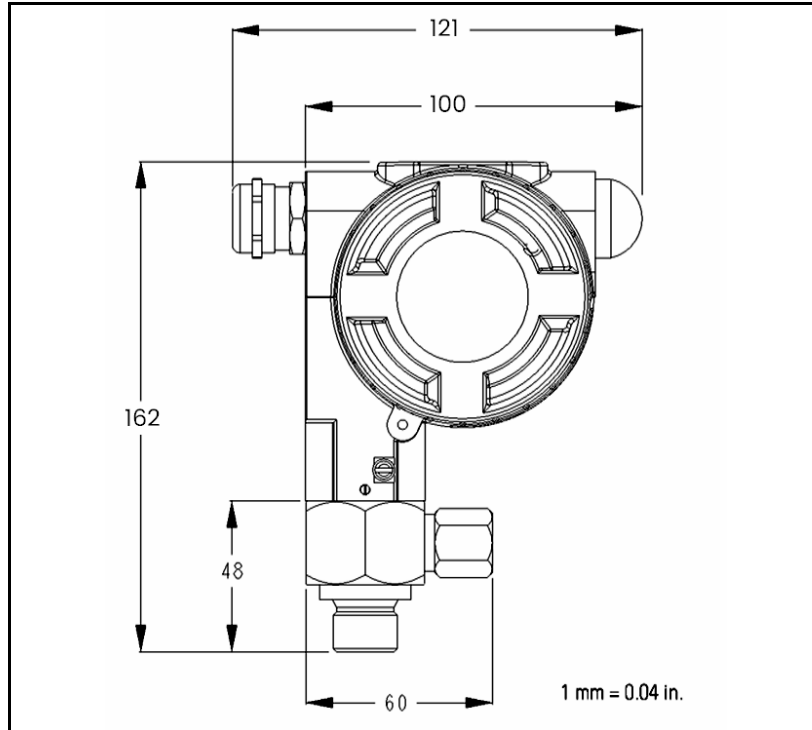

Figure 3: Standard DewPro Dimensions

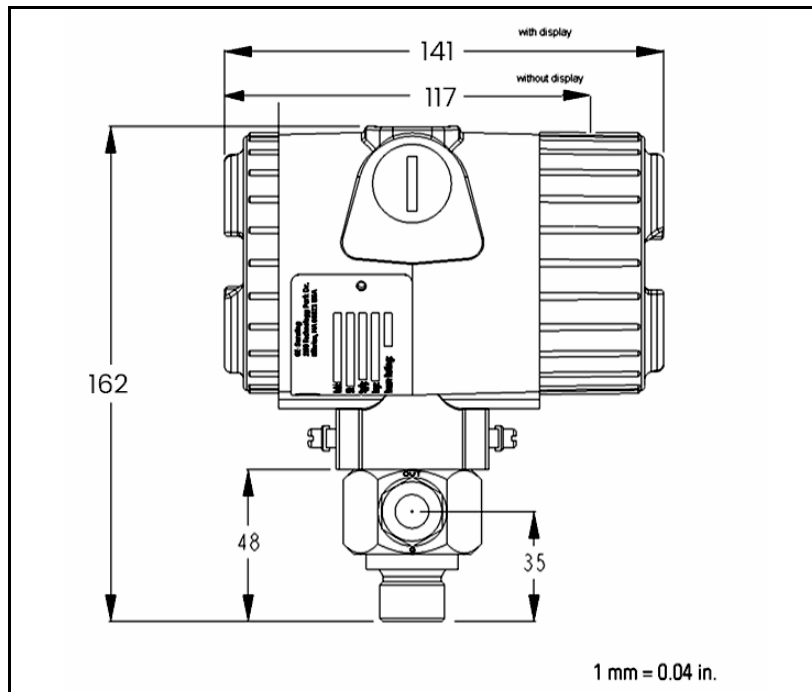

Figure 4: DewPro with Optional Display/User Interface

Chapter 2. Installation Guidelines

2.1 General Hints



CAUTION! Before installation, please read all instructions. The DewPro is designed to be mounted in pressurized systems. Take the necessary precautions when mounting or removing the DewPro.

- Mount the DewPro® vertically whenever possible to prevent particles or condensation from entering the bypass.
- Mount the DewPro® after a shutoff valve to depressurize it for removal from the process pipe in case of maintenance.



CAUTION! Do not over-tighten! The outlet fitting is connected to the bypass block with a G 1/4 straight thread (with gasket) which will seal if the fitting is simply hand-tightened. When connecting an external device, counter the fitting with a second wrench when tightening. If the inlet is equipped with a G 1/2 straight thread and gasket, the seal is obtained by simply hand-tightening the DewPro®.



CAUTION! If you are installing the DewPro into a pressurized system (up to 10 bar), depressurize the system before installing or removing the sensor. Pressurized systems require a stainless steel compression fitting.

2.2 Method I – Orifice at Outlet

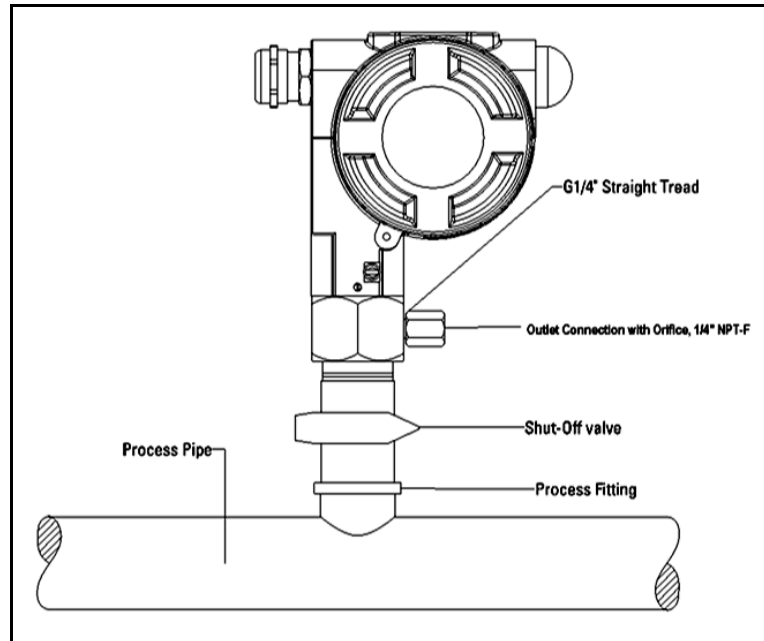

Figure 5: DewPro Installation with Orifice at the Outlet

2.2.1 Pressure Dewpoint

Refrigeration air dryers producing general instrument air are typically specified with a pressure dewpoint rating. The majority of dryers operate in a dewpoint range between +2°C to +10°C (+35°F to +50°F). A pressure of 7 to 8 bar (= 100 psig) is very common.

2.2.2 Air Flow

The DewPro is designed to measure the pressure dew point. By restricting the flow at the outlet of the integral bypass with an orifice, the sensor monitors the dewpoint at process pressure. The bleed off air to the atmosphere at 7 to 8 bar (100 psig), is approximately 70 cc/min. (=4 l/h or =0.14 cfh). For smaller sized dryers of 3m³/min.(=100 cfm) the air loss is only 0.002% of the air production and is negligible.

Despite the very low flow rate through the bypass as shown in Figure 2-1 on the previous page, the air sample in the DewPro bypass chamber is refreshed every second due to the small volume design. As a result, the sensor sees changes in moisture instantaneously.

Due to the low flow rate, the flow velocity is also very low at <0.01 m/sec. (=34m/h).The low flow velocity prevents the inlet filter from clogging, since there is not enough kinetic energy to push dust particles into the filter.

2.3 Method II - Orifice at Inlet

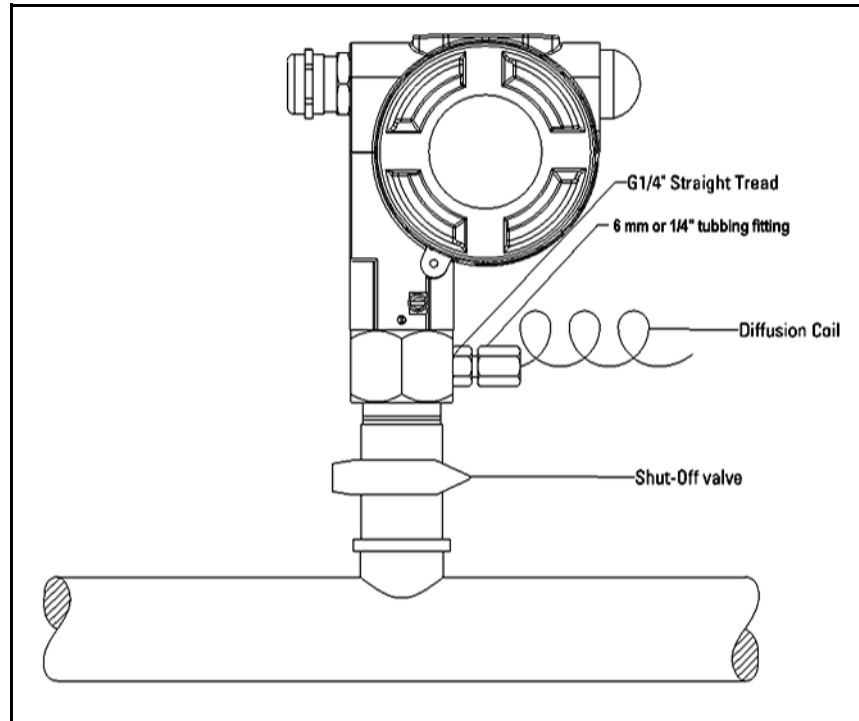

Figure 6: DewPro with Orifice Restriction at Inlet

In case the application requires the dew point measurement under atmospheric pressure, the orifice flow restriction is to be mounted at the inlet of the DewPro[®] bypass. This may not be typical for dryer applications. The dew point reading will be lower since the water vapor pressure is reduced by the factor of the pressure drop across the inlet orifice.

In this configuration, the outlet of the DewPro[®] bypass is not flow restricted and will be equipped with a 6 mm (1/4") tube fitting. In order to prevent back diffusion of water vapor from the ambient air, five feet of exhaust tubing should be mounted to the tube fitting, or, better, a diffusion coil from Panametrics can be used.

2.4 Method III – No Flow Restriction

2.4.1 Low Pressure Closed Loop

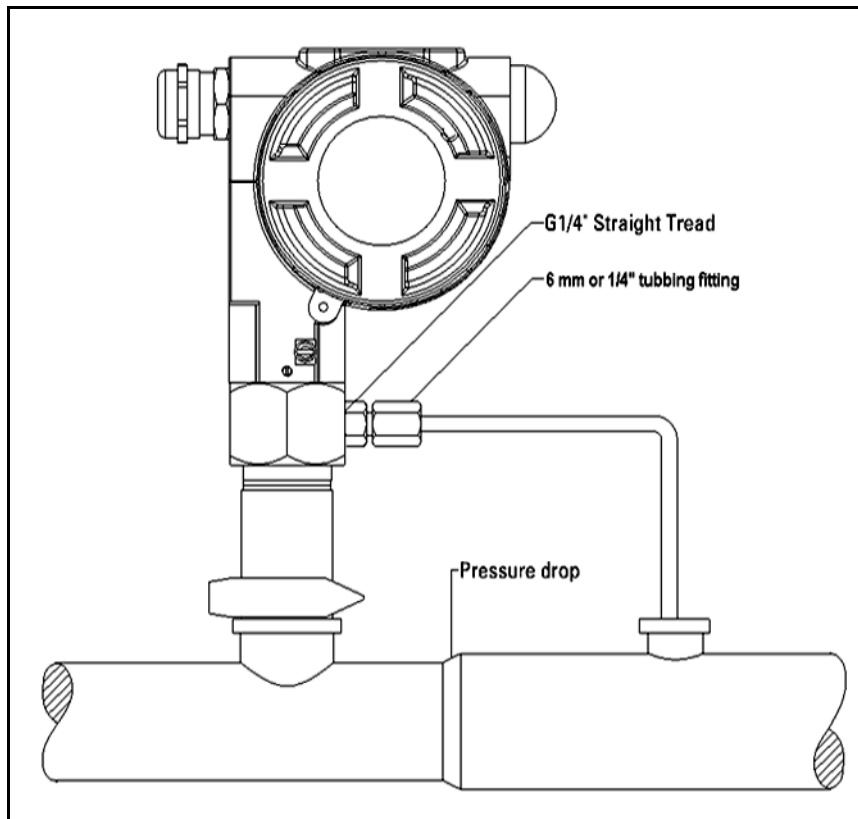

Figure 7: DewPro with No Flow Restriction

Closed loop systems, with dew points $> -15\text{ }^{\circ}\text{C}$, may operate at a low pressure. The air passing through the DewPro bypass is fed back to the main stream after a pressure drop in the main line.

In this configuration, the DewPro bypass has no flow restriction at the inlet and outlet. The outlet is equipped with a 6 mm (1/4") tube fitting to allow simple connection of the loop tubing.

2.5 Method IV – Remote Installation

In some cases there may not be enough room to install the DewPro directly to the process pipe. The tube connection at the inlet allows mounting the DewPro at a remote location, as shown in Figure 8 below. The functions of Methods I-III can be selected.

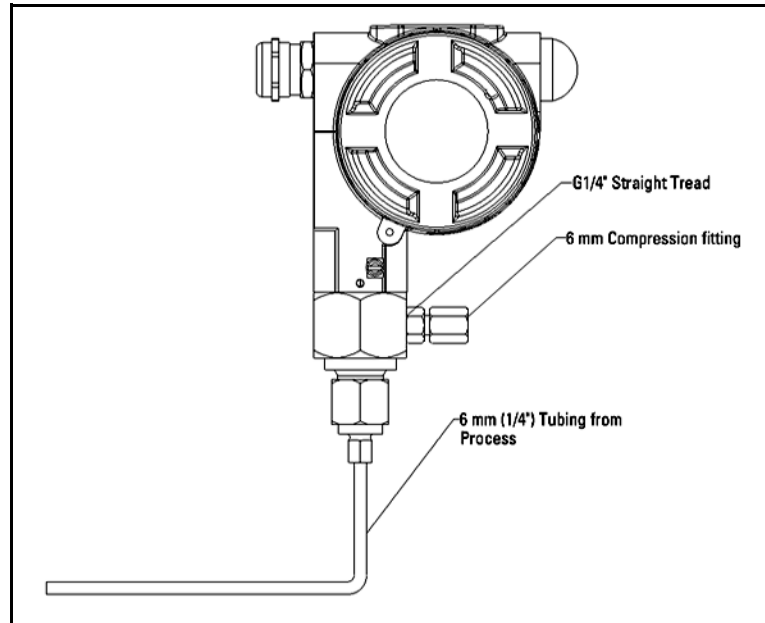

Figure 8: DewPro in Remote Installation

2.5.1 Mounting Brackets

The DewPro can be mounted on a wall, a plate or a pipe using a bracket available from Panametrics, as shown in Figure 9 below.

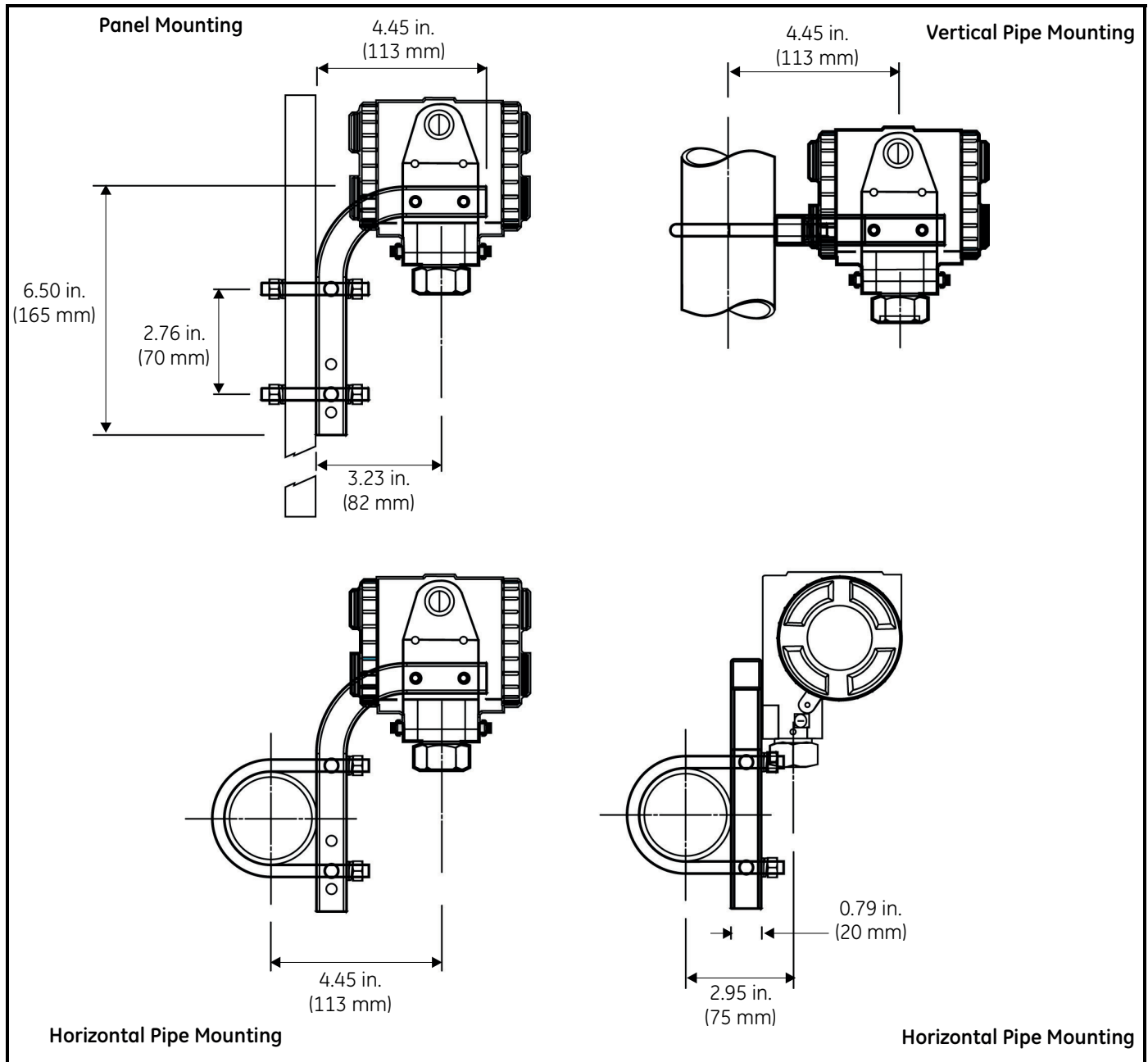

Figure 9: DewPro with Various Mounting Brackets

Chapter 3. Wiring Instructions

3.1 Wiring, General Guidelines

Note: If the DewPro is equipped with an optional display/user interface, please refer to Chapter 4.



CAUTION! The DewPro system contains electronic components that are susceptible to damage by static electricity. Proper handling procedures must be observed during the removal, installation, or other handling of internal boards or devices.

3.2 System Configuration

Figure 10 below shows various power supplies and displays for use with the DewPro.

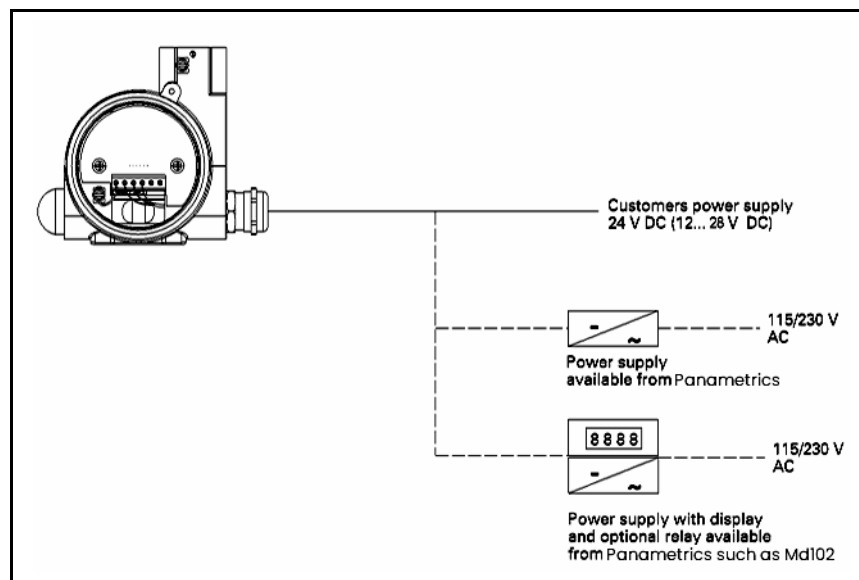

Figure 10: Power Supplies and Displays for DewPro

3.2.1 Designing the Loop

If users provide their own power supply, the voltage at the +/- terminal of the DewPro should not fall below 12 VDC. The maximum loop resistance is an important measure for selection of the supply voltage. Each device connected to the loop causes a voltage drop. For instance, using a loop-powered display with an input impedance of 50 Ohm will cause a voltage drop of 1 VDC at 20 mA using Ohm's law. Connecting the loop to a PLC will cause a voltage drop across the input.

When designing your loop, add up all voltage losses across the devices connected to the loop and add 12 V. The sum will be the minimum supply voltage required from the power supply. Calculate with a 20% safety factor.

3.3 Mounting in Normal Environments

A standard two-wire, stranded cable (shown in Figure 11 below) can be used to interconnect the DewPro with the power source.

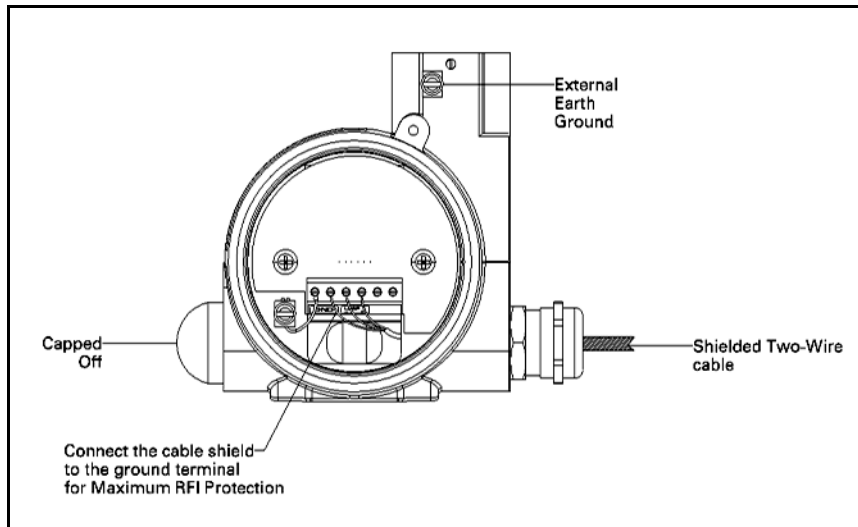

Figure 11: Standard Cable for Use with DewPro

3.4 Mounting in Environments with Severe Electrical Noise

The DewPro MMR30 meets the EMC requirements of IEC 61326 for equipment used in industrial locations. The MMR30 passed all tests to the standards IEC 61000-4- to the performance criterion A. Test details appear in Chapter 6, *Specifications*.

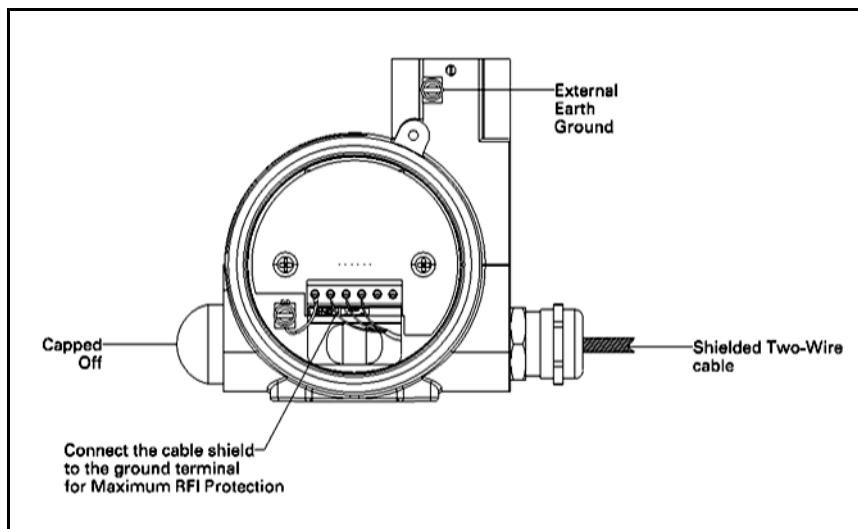

Figure 12: DewPro with Shielded Signal Cable

3.5 Electrical Connection

Figure 13 below shows the DewPro wiring connections.

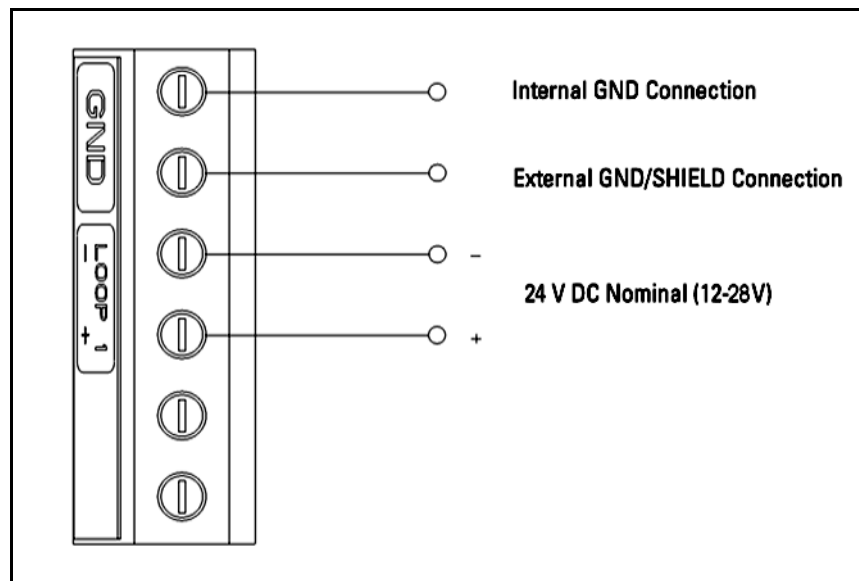

Figure 13: DewPro Wiring Connections

3.6 General Instructions

1. Unscrew the cap on the unit.
2. Loosen the cable gland located on the side of the unit.
3. Feed the cable through the conduit opening.

Note: Use a standard signal cable size.

4. Retighten the metal cable gland to meet IP67 and to relieve any stress on the wire.
5. Verify that a voltage between 12 and 28 V DC is across the terminals marked + and -.

Note: This is the voltage that appears across the DewPro terminals, not necessarily the power supply voltage due to voltage loss in wire length, displays, and indicators.

6. In order to meet EMI/RFI immunity, a two-wire shielded cable with a common foil shield layer is being used to power the MMR30. Removing the insulation by 3" allows users to pull back the foil, clamping it in between the metal cable gland. You must connect the ground wire to the internal grounding screw.

[no content intended for this page]

Chapter 4. Optional Display/User Interface

4.1 Installation

If the DewPro is equipped with an optional display/user interface, follow the procedure below to access the buttons.

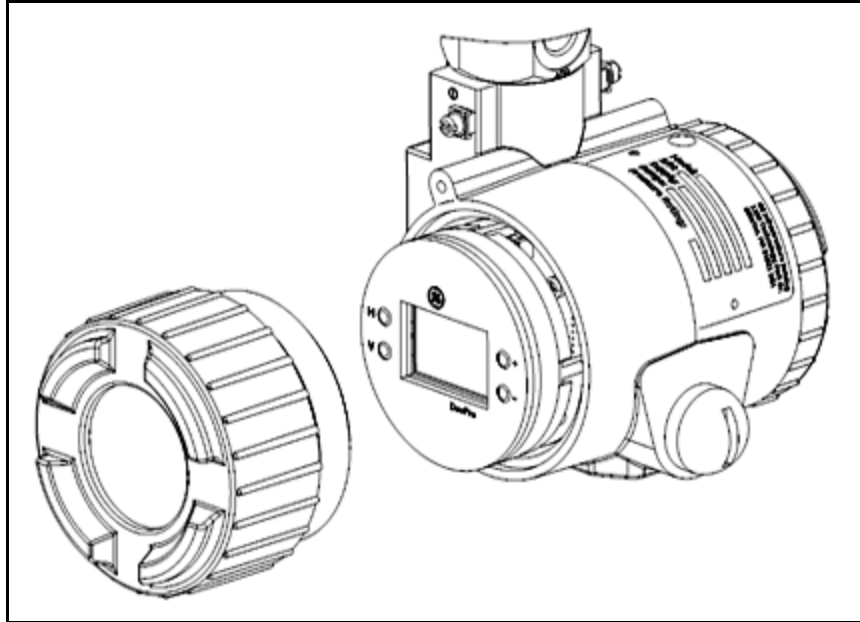

Figure 14: DewPro with Display Assembly

4.1.1 DewPro with Display Assembly

1. Unscrew and remove the protective window lid from the top of the DewPro (as shown in Figure 14 above), exposing the display module below. The buttons V, H, + and - are now accessible.

4.1.2 Replacing the Display

1. The display unit snaps onto the printed circuit board, resting on four posts. When removing the display, push one post to the outside, using a small screwdriver, and pull the display out.
2. Then unplug the display cable.

4.2 Description of the DewPro MMR30 Programming Matrix

In the DewPro MMR30 transmitter with display option, a matrix-style input is used for programming the unit of measure, measuring range, error status of output, and output adjustment. Each option is assigned coordinates on the 10 by 10 matrix, specified with V (vertical), H (horizontal) and a number for each. The following sections describe the features and usage of the various matrix locations as they apply to the MMR30.

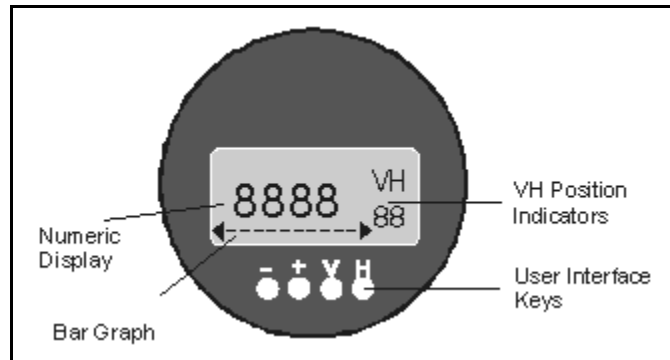

Figure 15: The MMR30 Optional Display

The display of the DewPro MMR30 continuously shows the current matrix location using the vertical (V) and horizontal (H) coordinates to designate the row and column, respectively. The bar graph represents the output current in an analog fashion (refer to Figure 15 above). See Appendix A for an enlarged overview of the matrix.

Table 1: Matrix Input for Programming

MMR30		H0	H1	H2	H3	H4	H5	H6	H7	H8	H9
Moisture Unit	V0	Display Moisture Value	Select Moisture Unit 1 = °C 2 = °F						Loop at Fault 1=110% 2=Hold 0=-10%	Loop Raw Reading	
Loop Range	V1			Dewpoint °C 4 mA	Dewpoint °C 20mA	Dewpoint °F 4 mA	Dewpoint °F 20 mA				
	V2										
Constant : Loop Hardware Calibration	V3	Pressure Constant in mmHg								Loop D/A Calibration Low	Loop D/A Calibration High
Temperature Unit: Loop 1 Hardware Calibration	V4	Display Temperature Value	Select Unit of Temperature: 0 =°C 1 =°F								
	V5										
	V6										

Table 1: Matrix Input for Programming

MMR30		H0	H1	H2	H3	H4	H5	H6	H7	H8	H9
Loop 2 Hardware Calibration	V7										
Access Key	V8										Input Locking 50 = Unlock
Misc. Setup	V9	Display Present Error	Previous Error	Unit ID	Software Version		Reset to Defaults 50=Reset				System Reset 50 = Reset

4.2 Description of the DewPro MMR30 Programming Matrix (cont.)

Table 2: Matrix Number and Moisture Units

Matrix	Moisture Unit
1	Td °C
2	Td °F

You select the desired option by entering the matrix position. Movement through the matrix is accomplished by using the “V” and “H” buttons to move to another row or column, as shown in the example below. At any location where a value may be changed by the user, the desired value is programmed using the “+” and “-” buttons.

4.2.1 Example

To set the dew point value to -10°C for 4 mA (V1 H2 on matrix):

1. Press the V key until the display shows V1.
2. Press the H key until the display shows H2.
3. Use the + or - key to change the numeric value to -10. The digit to be changed is flashing.
4. Proceed to any part of the matrix.

4.3 Special Functions of the Push Buttons

1. Reset to “Normal” Display: Pressing the “V” and “H” buttons simultaneously returns the user to VH 00 (normal display).
2. Display Only: Note that seven (7) matrix locations are for display only and may not be changed by the user (refer to *Table 1 on page 16* or *“Matrix Table for Programming” on page 33*). The “display only” fields are as follows:
 - VH 00 = normal display (in dewpoint)
 - VH 08 = indicates digitized moisture signal
 - VH 40 = temperature display
 - VH 90 = during a system alarm, displays the error code for the fault encountered
 - VH 91 = during normal operation, the previous error code is displayed for reference
 - VH 92 = displays the factory issued identification number
 - VH 93 = displays the factory issued reference number designating the device type and software version
3. Default Values
A default value is assigned to each programmable matrix field. The values are present after a reset to factory programmed data has been executed (see VH 95).

4.4 Functions of the Matrix

This section describes the functions available to the user through the matrix grouped by common function areas. The function is accessed by positioning to the specified location within the matrix.

4.4.1 System Administration Functions

1. Unlocking/Locking the Matrix

Table 3:

Location in Matrix	Description of Function
VH 89	This location allows the user to lock and unlock the matrix input functions. When the matrix is locked, "V" and "H" keys are still functional but the "+" and "-" keys are disabled. This prevents unauthorized modification of any of the user input functions, such as output ranging or unit selection. Entering the value "50" in this location unlocks the matrix. Any other value locks the matrix. Default: 0

2. System Reset

Table 4:

Location in Matrix	Description of Function
VH 99	This location allows the user to a reset of the system electronics, similar to removing and re-applying power to the instrument. No system parameter settings are modified. Entering the value "50" in this location initiates the reset, and after approximately five (5) seconds the reset is executed. After the reset, normal operation is resumed at location VH 00.

3. Transmitter Identification

Table 5:

Location in Matrix	Description of Function
VH 92	This location displays the identification number of the transmitter. The display should read "200."

4. Software Version

Table 6:

Location in Matrix	Description of Function
VH 93	This location displays the version number (3.00) of the instrument software.

4.4.2 Moisture Measurement Functions

1. Display Present Process Value

Table 7:

Location in Matrix	Description of Function
VH 00	This location displays the present process humidity value measured by the instrument. The unit of measure for the displayed value (i.e., dewpoint or unit selected under VH 01) is selected in position VH 01. The bar graph beneath the numeric display represents the position of the present value within the range programmed for the selected unit of measure.

2. Select Unit of Measure for Display

Table 8:

Location in Matrix	Description of Function
VH 01	This location selects the unit of measure to be used for the humidity value display. The possible selections are as follows: 1 = °C dewpoint 2 = °F dewpoint Default: 1

3. Loop #1 at Fault

Table 9:

Location in Matrix	Description of Function
VH 07	This location specifies the state of current output corresponding to the detection of a fault with either the humidity sensor or the measurement circuitry. The possible selections are: 0 = -10% (3.6 mA) 1 = 110% (22 mA) 2 = Hold at previous level Default: 1

4.4.2 Moisture Measurement Functions (cont.)

1. Displaying the Moisture Frequency

Table 10:

Location in Matrix	Description of Function
VH 08	When this location is selected, the A/D counts from the moisture measurement circuit are displayed.

4.4.3 Setting the Output Range for the Humidity 4–20 mA Output

1. Range of Humidity Values (Assign any value to 4 and 20 mA to establish desired output range.)

Table 11:

Location in Matrix	Description of Function	Default Values
VH 12	°C dewpoint 4 mA	-15
VH 13	°C dewpoint 20 mA	+85
VH 14	°F dewpoint 4 mA	5
VH 15	°F dewpoint 20 mA	185

2. Pressure Constant Adjustment

Table 12:

Location in Matrix	Description of Function
VH 30	This location allows the user to enter a value for the process pressure. The value is entered in mmHg. This value is only used for the calculation of the unit grams/kg dry air. Default: 760

4.4.3 Setting the Output Range for the Humidity 4–20 mA Output (cont.)

3. Calibrating the Current Output

Table 13:

Location in Matrix	Description of Function
VH 38 VH 39	<p>These locations are used to calibrate the 4 mA and 20 mA settings of the humidity output current loop. This output comes calibrated from the factory and should not normally need adjustment. To check the setting, connect a current meter in series with the power terminals for loop (see Chapter 3). Move to matrix location VH 38. The output will automatically change to the 4 mA setting. Adjust as necessary using the “+” and “-” keys. Move to location VH 39. The output will automatically change to the 20 mA setting. Again, adjust as necessary. Move to any other matrix location to return the output to normal operation.</p> <p><i>Note: If the matrix input is locked (VH 89), the calibration values are displayed but the current output is unaffected.</i></p>

4.4.4 Temperature Measurement Functions



CAUTION! The standard MMR30 does not offer a temperature measurement output. The second analog output is only available at special request. These functions only apply to this special version.

1. Displaying the Measured Temperature

Table 14:

Location in Matrix	Description of Function
VH 40	<p>Selecting this location displays the present process temperature. The unit of measure (°C/°F) is the unit selected in location VH 41 (see Table 1 on page 16). The bar graph displays the percentage of output for the programmed output range.</p>

2. Selecting the Temperature Unit

Table 15:

Location in Matrix	Description of Function
VH 41	<p>This location allows the user to select either °C or °F as the temperature measurement unit to be displayed in location VH 40. Setting this location to “0” selects °C, and setting to “1” selects °F. Default: 0</p>

4.4.5 Error Codes

1. Display the Present Error Code

Table 16:

Location in Matrix	Description of Function
VH 90	This field displays a number associated with an error code. If no error condition exists, the location displays "0." During normal operation, it is possible for the humidity channel to be in error, yet have a temperature channel read correctly. It is also possible for the temperature to be in error, but have the humidity read correctly. If a moisture unit is selected that needs both humidity and temperature (such as dewpoint) in order to be properly calculated, the error conditions for $T_d < -15^{\circ}\text{C}$ and $T_d > +85^{\circ}\text{C}$ will be set. Follow the instructions on the next page to properly detect the correct error code.

4.4.6 Directions for Detecting the Correct Error Code

1. Take the error code displayed at the matrix location VH 90 and divide it by 16. The digit(s) before the decimal point represent the error code associated with the temperature channel.

Table 17:

Temperature Error		
	Bit: 0010	
	xxxx	
		Temperature < -15°C
		Temperature > +40°C
		Output on CH.2 less than 4 mA
		Output on CH.2 greater than 20 mA

2. To calculate the moisture error code, take the remainder of the previous division (the digit(s) after the decimal point) and multiply it by 16.

Table 18:

Moisture Error		
	Bit: 0111	
	xxxx	
		RH < 0%
		RH > 100%
		Output on CH.1 less than 4 mA
		Output on CH.1 greater than 20 mA

3. Use Table 4-3 on the next page to convert both numbers into their respective bit codes.

Note: Every "1" corresponds to an error. See the example below Table 4-3 for help when calculating. Please refer to "Troubleshooting" on page 27, for further information.

4.4.6 Directions for Detecting the Correct Error Code (cont.)

Table 19: Error Code Conversion Chart

0	0000
1	0001
2	0010
3	0011
4	0100
5	0101
6	0110
7	0111
8	1000
9	1001
10	1010
11	1011
12	1100
13	1101
14	1110
15	1111

Example 1:

Error Code: 1

1. $1/16 = 0.0625$ No temperature error
2. $0.0625 \times 16 = 1$ Moisture error code = 1
3. Error Code Bit Map **(0)** **(1)**
0000 0001
+ >> RH < 0% (gas too dry)

Example 2:

Error Code: 39

1. $39/16 = 2.4375$ Temperature error code = 2
2. $0.4375 \times 16 = 7$ Moisture error code = 7
3. Error Code Bit Map **(2)** **(7)**
0010 0111
++ >> Moisture Unit Selected
Depends on Temperature
+ >> Output 1 < 4mA
+ >> Temperature > + 85°C

[no content intended for this page]

Chapter 5. Troubleshooting

5.1 Problems and Recommended Solutions

IMPORTANT: The loop current is outside the range of 4-20 mA, as shown on display or current meter. (In some cases, 22 mA can be ordered as the fault current.)

IMPORTANT: The process dewpoint is out of range. If the dewpoint is above +85°C (+185°F), the current will go to 22 mA. Apply dry air for 20 minutes. If the dewpoint doesn't decrease, consult the factory.

If the dewpoint is below -15°C (+5°F), the current will go below 4 mA and then to 22 mA as the fault current. Expose the DewPro to wetter for several minutes. If the error remains, the cause may be a defective sensor assembly or an electronics malfunction. Consult the factory.

IMPORTANT: There is no current.

IMPORTANT: Check the voltage and polarity across +/- terminals with a DC voltmeter. If the voltage is within 12-28 V DC, consult the factory.

IMPORTANT: The response time is very slow.

IMPORTANT: Verify the flow with an air flowmeter. If the orifice is at the outlet of a 7 to 8 bar (=100 psig) process pressure, the air flow should indicate 20 to 30 l/h (500 cc/min., 1 cfm). If the flow is dramatically lower, the inlet filter may be clogged. Remove the 2 micron filter and clean it with a solvent or replace it.

5.2 Removing the Filter

Figure 16 below illustrates filter parts for removal.

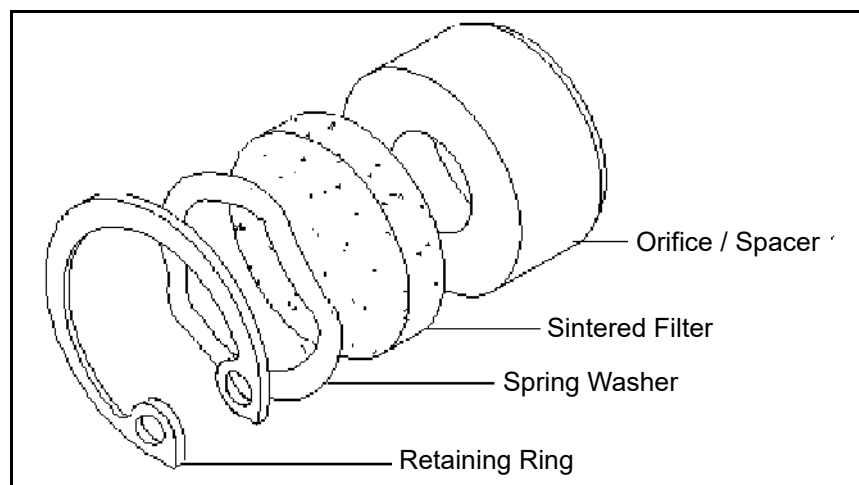

Figure 16: Filter Parts

[no content intended for this page]

Chapter 6. Technical Specifications

6.1 MMR30 Specifications

6.1.1 Sensing Element

Silicon-based polymer, capacitance principle, IC electronics

6.1.2 Measurement Range

-15°C to +85°C (+5°F to +185°F)

6.1.3 Dew Point Accuracy

±1°C (±1.8°F) for dew points above 0°C (+32°F)

6.1.4 Repeatability

±1°C (±1.8°F)

6.1.5 Standard Operating and Storage Temperature

-15°C to +85°C (+5°F to +185°F)

6.1.6 Air Bleed Off at 7 to 8 bar (100 psig)

Approximately 28 l/h (1 cfh) (volume related to atmospheric pressure)

6.1.7 Maximum Operating Pressure

17 bar, 1.7 MPa (250 psia)

6.1.8 Output

Loop current 4 to 20 mA; 16 µA resolution

6.1.9 Flow Block

316 stainless steel (1.440/1.4436) with ½" (12.7 mm) MNPT or G ½ thread (DIN ISO 228) and gasket seal

6.1.10 Wrench Width for Flow Block

42 mm (1 5/8")

6.1.11 Electronics

Microcontroller operated

6.1.12 Moisture Unit

Dew point temperature in °C or °F (hardware selectable)

6.1.13 Supply Power

24 VDC nominal, tolerance 12 to 28 VDC

6.1.14 Protection

Type 4X (IP67)

6.1.15 Weight

2 kg (4.4 lb)

6.1.16 European Compliance

Complies with EMC Directive 2004/108/EC and PED 97/23/EC for DN <25

6.2 Optional Onboard Display with User Interface

The optional onboard display with user interface uses a matrix configurator for:

- range changes
- unit of measure selection
- current loop adjustment
- error diagnostics
- current value selection for fault conditions

6.3 EMI/RFI

Performance Criterion A:

1. Conducted Emission Test as per CISPR 11 Class A, 2004
2. Radiated Emission Test as per CISPR 11 Class A, 2004
3. Radiated Susceptibility Test as per IEC 61000-4-3, 2002
4. Electrostatic Discharge Test as per IEC 61000-4-2, 2001
5. Electrical Fast Transient Test as per IEC 61000-4-4, 2004
6. High Energy Surge Immunity Test as per IEC 61000-4-5, 2001
7. Power Frequency Magnetic Field Test as per IEC 61000-4-8, 2001

6.4 EMC

IEC 61326, Industrial Locations

Chapter 7. Accessories

The following accessories are available for the DewPro MMR30:

- Single power supply
- Panel mount display, power supply, no relays
- Panel mount display, power supply, two alarms
- Panel mount display, power supply, two alarms
- 4 to 20 repeating output

Consult Panametrics Measurement & Control for further information.

[no content intended for this page]

Appendix A. Matrix Table for Programming

Table 20: Matrix Input for Programming

MMR30		H0	H1	H2	H3	H4	H5	H6	H7	H8	H9
Moisture Unit	V0	Display Moisture Value	Select Moisture Unit 1 = °C 2 = °F						Loop at Fault 1=110% 2=Hold 0=-10%	Loop Raw Reading	
Loop Range	V1			Dewpoint °C 4 mA	Dewpoint °C 20 mA	Dewpoint °F 4 mA	Dewpoint °F 20 mA				
	V2										
Constant: Loop Hardware Calibration	V3	Pressure Constant in mmHg								Loop D/A Calibration Low	Loop D/A Calibration High
Temperature Unit: Loop 1 Hardware Calibration	V4	Display Temperature Value	Select Unit of Temperature: 0=°C 1=°F								
	V5										
	V6										
Loop 2 Hardware Calibration	V7										
Access Key	V8										Input Locking 50 = Unlock
Misc. Setup	V9	Display Present Error	Previous Error	Unit ID	Software Version		Reset to Defaults 50=Reset				System Reset 50 = Reset

[no content intended for this page]

Warranty

Each instrument manufactured by Panametrics is warranted to be free from defects in material and workmanship. Liability under this warranty is limited to restoring the instrument to normal operation or replacing the instrument, at the sole discretion of Panametrics. Fuses and batteries are specifically excluded from any liability. This warranty is effective from the date of delivery to the original purchaser. If Panametrics determines that the equipment was defective, the warranty period is:

- One year from delivery for electronic or mechanical failures
- One year from delivery for sensor shelf life

If Panametrics determines that the equipment was damaged by misuse, improper installation, the use of unauthorized replacement parts, or operating conditions outside the guidelines specified by Panametrics, the repairs are not covered under this warranty.

The warranties set forth herein are exclusive and are in lieu of all other warranties whether statutory, express or implied (including warranties or merchantability and fitness for a particular purpose, and warranties arising from course of dealing or usage or trade).

Return Policy

If a Panametrics instrument malfunctions within the warranty period, the following procedure must be completed:

1. Notify Panametrics, giving full details of the problem, and provide the model number and serial number of the instrument. If the nature of the problem indicates the need for factory service, Panametrics will issue a RETURN AUTHORIZATION NUMBER (RAN), and shipping instructions for the return of the instrument to a service center will be provided.
2. If Panametrics instructs you to send your instrument to a service center, it must be shipped prepaid to the authorized repair station indicated in the shipping instructions.
3. Upon receipt, Panametrics will evaluate the instrument to determine the cause of the malfunction.

Then, one of the following courses of action will then be taken:

- If the damage is covered under the terms of the warranty, the instrument will be repaired at no cost to the owner and returned.
- If Panametrics determines that the damage is not covered under the terms of the warranty, or if the warranty has expired, an estimate for the cost of the repairs at standard rates will be provided. Upon receipt of the owner's approval to proceed, the instrument will be repaired and returned.

[no content intended for this page]

Contact Us!

<p>Break/fix technical support issues for a product you currently have</p>	<ul style="list-style-type: none"> • Global Technical Support Team <p>Email: mstechsupport@bakerhughes.com Phone: 8000-833-9438, option 3.</p>
<p>RMA Repair Requests, Calibration Requests, Document and Certificate requests for a product you currently have</p>	<ul style="list-style-type: none"> • International – Baker Hughes Customer care <p>Email: gesensingorders@bakerhughes.com Phone: +36 27 565 314</p> <ul style="list-style-type: none"> • North America only – Baker Hughes North America In House Services <p>Email: namservice@bakerhughes.com Phone: (281)542-3650</p>
<p>Quotes, PO's and PO inquiries, Orders changes and Order inquiries, document requests for new product</p>	<ul style="list-style-type: none"> • International – Baker Hughes Customer Care <p>Email: gesensingorders@bakerhughes.com Phone: +36 27 565 314</p> <ul style="list-style-type: none"> • North America only – Baker Hughes North America Customer Care <p>Email: custcareboston@bakerhughes.com Phone: 800-833-9438, option 1.</p>

Copyright 2020 Baker Hughes company.

This material contains one or more registered trademarks of Baker Hughes Company and its subsidiaries in one or more countries. All third-party product and company names are trademarks of their respective holders.

A40251524 Rev.B