

Platinum/Optima CVE Pocket Guide



TELEDYNE ISCO
Everywhereyoulook™

Platinum/Optima CVE Refrigerated Sampler Pocket Guide

This pocket guide is not intended to replace the instruction manual. Read the instruction manual thoroughly before operating the sampler.

COPYRIGHT © 2018 by
Teledyne ISCO
4700 Superior St.,
Lincoln, Nebraska, U.S.A. 68504
Phone: (402) 464-0231
Toll Free: (800) 228-4373
FAX: (402) 465-3022

Part Number: 69-2303-214
Released: October 2018

Use and Disclosure of Data
Information contained herein is classified as EAR99 under the U.S. Export Administration Regulations. Export, reexport or diversion contrary to U.S. law is prohibited.

Platinum/Optima CVE Refrigerated Sampler Pocket Guide

Table of Contents

1. Introduction

- 1.1 Features 1-1
- 1.2 Specifications 1-6

2. Installation

- 2.1 Sampler Installation Overview 2-1
- 2.2 Positioning the Sampler 2-2
- 2.3 Connecting Power 2-5
- 2.4 Installing a Bottle Kit 2-7
 - 2.4.1 24-1 Liter 2-9
 - 2.4.2 4-15 Liter (Platinum only). . . 2-10
 - 2.4.3 12-2.5 Liter 2-11
 - 2.4.4 Single Bottle Configuration . . 2-12
- 2.5 Attaching the Suction Line 2-13
 - 2.5.1 Vinyl Suction Line 2-14
 - 2.5.2 PTFE-lined Suction Line . . . 2-15
- 2.6 Attaching a Strainer 2-16
 - 2.6.1 Alternative to Strainers 2-17
 - 2.6.2 Max Unanchored Length . . . 2-17
- 2.7 Routing Suction Line and Strainer . 2-18
- 2.8 External Devices 2-19

2.8.1 Other Device Connections . . .	2-20
2.9 Configure and Program the Sampler . . .	2-24
2.10 Locking the Sampler	2-24
2.11 Quick Start Guide	2-25
2.11.1 Program Ready Screen	2-25
2.11.2 Program Configuration	2-25
2.11.3 Sample Interval	2-27
2.11.4 Time Option	2-27
2.11.5 Bottle Options	2-27

3. Programming

3.1 Control Panel Description	3-1
3.2 Getting Started	3-3
3.3 Configuring the Sampler	3-4
3.3.1 Set Clock	3-5
3.3.2 Bottle Configuration	3-6
3.3.3 Suction Line	3-7
3.3.4 Rinse Cycle	3-8
3.3.5 Liquid Detector and Recycle	3-9
3.3.6 Float Input	3-10
3.3.7 Output Pins	3-10
3.3.8 Refrigeration	3-12
3.3.9 Program Lock	3-13
3.3.10 Language Selection	3-14
3.3.11 Set Unit ID	3-15
3.3.12 Diagnostics	3-16
3.3.13 Exit Configuration	3-16
3.4 Sampling Program Overview	3-16
3.4.1 Program Configuration	3-18
3.4.2 Sampling Cycle	3-18
3.4.3 Sample Interval	3-21
3.4.4 Bottle Configuration	3-22
3.4.5 Program Run Options	3-24
3.4.6 Program Events	

.....	3-27
3.5 Programming Steps	3-28
3.5.1 Sample Pacing	3-28
3.5.2 Time Paced	3-29
3.5.3 Flow Paced	3-29
3.5.4 Bottles per Sample Event ..	3-30
3.5.5 Switch on Time Indexing ...	3-31
3.5.6 Real Time Indexing	3-31
3.5.7 Samples Per Bottle	3-32
3.5.8 Run Continuously	3-33
3.5.9 Sample Second	3-34
3.5.10 Flow Pulses, Analog Input ..	3-34
3.5.11 Composite Samples	3-34
3.5.12 Pressurized Line	3-35
3.5.13 Timed Delay	3-35
3.5.14 Auto Re-Run	3-37
3.5.15 Timed Stop/Max Run Time ..	3-37

4. Operation

4.1 Start a Sampler Program	4-1
4.1.1 Sample Calibration	4-2
4.1.2 Start Time Delay	4-3
4.1.3 The Run State	4-3
4.1.4 Completed Program	4-4
4.2 Pause or Stop a Running Program ..	4-5
4.3 Post Sampling Activities	4-6
4.3.1 View the Log	4-6
4.3.2 User Interface Icon	4-10
4.3.3 Sample Bottle Removal	4-12
4.4 Grab Samples	4-13
4.5 Velocity Control Valve	4-14

5. Maintenance

5.1 Periodic Maintenance Checklist	5-1
5.2 Fuse	5-2
5.3 Cleaning the Sample Chamber	5-3
5.3.1 Sample Chamber Removal ...	5-3
5.3.2 Sample Chamber Installation	5-4
5.3.3 Installing the Tubing	5-4

5.3.4	Sample Chamber Parts	5-8
5.4	Compressor/Vacuum Pump	5-10
5.5	Clean or Replace Wetted Parts	5-11
5.5.1	Sampler Cleaning Guidelines	5-11

Platinum/Optima CVE Refrigerated Sampler

Section 1 Introduction

1.1 Features

The sampler features are identified in Figures 1-1 through 1-4 and described in Table 1-1.

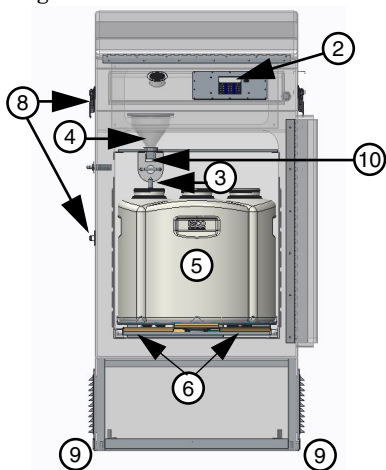

Figure 1-1 Sampler features (Front)

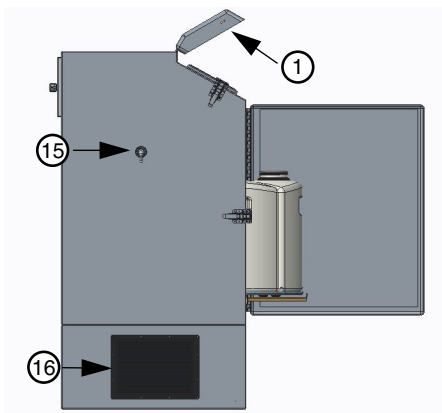

Figure 1-2 Sampler features (left side)

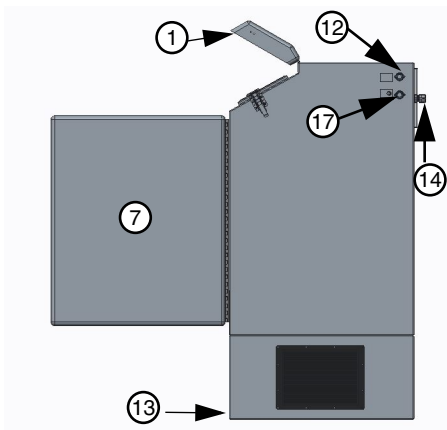

Figure 1-3 Sampler features (right)

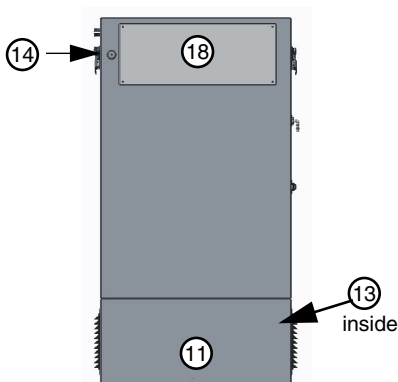

Figure 1-4 Sampler features (back)

Table 1-1 Sampler Features

Item	Name	Description
1	Control Panel Cover	Protects the control panel display and keypad. Can be locked with user supplied padlock.
2	Control Panel	Supports user control and programming of sampler operation.
3	Discharge Tube	Carries liquid to the sample bottle.
4	Sample Chamber	Sample is measured and collected in the chamber then discharged into sample container.

**Table 1-1 Sampler Features
(Continued)**

Item	Name	Description
5	Bottles	Hold the collected samples.
6	Sequential Table	Rotates the bottles.
7	Refrigerator Door	Protects the collected samples inside the refrigerated compartment.
8	Latch	Secures the door. The latch mechanism may be locked with a user-supplied padlock.
9	Level Adjustment Feet	The sampler includes four level adjustment feet, one at each corner. Use these to keep the sampler leveled.
10	Liquid Detector	The liquid-sensing electrodes detect fluid in the sample chamber.
11	Lower Back Cover	Access to Refrigeration Module.
12	External Device Connection	Supports connections to external devices such as a flow meter for sample pacing or 4-20mA.

**Table 1-1 Sampler Features
(Continued)**

Item	Name	Description
13	Refrigeration Module	Modular, corrosion-resistant refrigeration assembly cools the refrigerated compartment to a user-selected. Temperature of 2 to 5 °C (35 to 41°F).
14	AC Mains Line Cord	Connects to AC power source.
15	Sample Line intake	The sample intake line connects here.
16	Air Vents	Refrigeration air vents
17	Aux. Outputs	Alarm, Fl. Start, Fl. Start/Stop Run Status.
18	Top Back Cover	Access to the vacuum pump, fuses, and electrical components.

CAUTION

When lifting the sampler, cautiously lift with 2 people (one on each side) with the door closed and latched. Recommend using a lifting device.

1.2 Specifications

Table 1-2 Specifications

General	
Size (H×W×D):	49 x 25.5 x 25.5 inches 124.4 x 64.7 x 64.7 cm
Weight (empty):	97 kg 214 lbs.
Bottle Configuration:	6 configurations available: 24, 1-liter PP 12, 2.5-liter PP 4, 15-liter PP 1, 20-liter PE 1, 10-liter PE or glass
Refrigerator Body:	Molded fiberglass with UV resistant gel coat.
Power Requirements:	<i>115 VAC ±10%, 60 Hz</i> Running current 12 amperes <i>230 VAC ±10%, 50 Hz</i> Running current 6 amperes
Installation Category:	II
Pollution Degree:	3
Maximum Altitude:	2,000 meters 6,562 feet
Humidity:	0 to 100%
Operational Temperature:	-29 to 49 °C -20 to 120 °F

Table 1-2 Specifications (Continued)

Tubing	
Intake Suction Tubing Length:	1 to 45 m 3 to 150 feet
Material:	Vinyl or PTFE-lined polyethylene
Inside Diameter:	$\frac{3}{8}$ inch (9 mm) $\frac{1}{2}$ inch (12mm)
Maximum Suction Lift:	28 ft. (8.5 m) with $\frac{3}{8}$ inch suction line 22 ft. (7.0 m) with $\frac{1}{2}$ inch suction line
Typical Repeatability:	± 5 ml or $\pm 5\%$
Typical Line Velocity at Head Height: 115VAC/60Hz 28 ft. lift Pump	$\frac{3}{8}$ inch suction line 3ft: 9.84ft/s 10ft: 7.38ft/s 20ft: 4.50ft/s
Typical Line Velocity at Head Height: 230 VAC/50Hz 28 ft. lift Pump	$\frac{3}{8}$ inch (9 mm) suction line 1 m: 2.04 m/s (6.70 ft/s) 4 m: 2.10 m/s (6.89 ft/s) 7 m: 1.52 m/s (4.99 ft/s) $\frac{1}{2}$ inch (12 mm) suction line 1 m: 1.74 m/s (5.71 ft/s) 3 m: 1.60 m/s (5.25 ft/s) 7 m: 1.33 m/s (4.36 ft/s)

Table 1-2 Specifications (Continued)

Liquid Presence Detector:	Wetted Liquid-sensor electrodes.
Controller	
Enclosure Rating:	NEMA 4X IP66
Program Memory:	Non-volatile ROM (Flash)
Flow Meter Signal Inputs:	Pulses (dry contacts) 4-20 mA 0-5 VDC 0-10 VDC
Digital Alarms:	1 output, with 5 alarm configurations
Number of Composite Samples:	Programmable from 1 to 999 samples.
Internal Clock Accuracy:	1 minute per month at 25 °C
Software	
Sample Frequency:	1 to 9999 minutes, in 1-minute increments 1 to 9,999 flow pulses

Table 1-2 Specifications (Continued)

Sampling Modes:	Constant Time, Constant Volume Variable Time, Constant Volume Constant Flow, Constant Volume Variable Flow, Constant Volume Time and Flow Based Sampling (refer to manual for more info) Incremental Time per Bottle Incremental Flow per Bottle
Sample Volumes:	20 to 400 ml
Sample Retries:	If no sample reaches the liquid-sensor electrodes, recycle will activate up to 4 attempts.
Rinse Cycles:	Rinsing of suction line up to 4 rinses for each sample collection.
Controller Diagnostics:	Live diagnostics while sampling.

Platinum/Optima CVE Refrigerated Sampler

Section 2 Installation

2.1 Sampler Installation Overview

The following sections provide general instructions for placing the sampler into operation. In typical applications, the steps are:

1. Positioning the sampler (Section 2.2)
2. Connecting power. (Section 2.3)
3. Installing a bottle kit. (Section 2.4)
4. Attaching the suction line. (Section 2.5)
5. Attaching a strainer. (Section 2.6)
6. Routing the suction line and strainer. (Section 2.7)
7. Connecting the sampler to external devices. (Section 2.8)
8. Configuring and programming the sampler. (Section 2.9)
9. Locking the sampler. (Section 2.10)

2.2 Positioning the Sampler

There are a few considerations when selecting a site for the sampler. The foremost concern should be personal safety.

The installation and use of this product may subject you to dangerous working conditions that can cause you serious or fatal injuries. Take any necessary precautions before entering the work site. Install and operate this product in accordance with all applicable safety and health regulations, and local ordinances.

WARNING

If this product is used in a manner not specified in this manual, the protection provided by the equipment may be impaired.

WARNING

This product has not been approved for use in hazardous locations as defined by the National Electrical Code.

WARNING

The sampler is heavy. When lifting, use a two-person lift from the right and left sides. When possible, move the sampler using a two-wheeled hand cart from the side. To prevent damage to the refrigeration system, do not tip the sampler more than 45°.

Dangerous Locations – If you must enter a manhole, confined space, or other dangerous location to install the suction line and strainer, observe standard safety precautions.

Support – The sampler should be installed on a surface capable of safely supporting the sampler, full liquid containers, and personnel.

AC Power – The mains line cord is the disconnect device should you need to remove power. Therefore, the electrical power outlet should be accessible.

Environmental – The sampler is designed for outdoor use. Refer to Table 1-2 for environmental specifications. When possible, avoid subjecting the sampler to chemical attacks and direct sunlight.

Avoid Submersion – The sampler is rated NEMA 4x (IP66), which does not protect from submersion. In the event of submersion, liquid entering the refrigeration system could permanently damage the sampler; liquid entering the bottle compartment could contaminate the collected samples. Liquid entering the electrical compartment for the refrigeration system could result in a short circuit and possible shock hazard.

Liquid Sample Collection Point – It is best to keep the distance between the sampler pump and the collection point as short as possible. Also, the pump inlet should be located above the liquid surface to be sampled with no liquid traps. Gravity will aid suction line rinses and allow the line to drain, thereby reducing the

possibility of sample cross-contamination. Refer to Table 1-2 for maximum suction line lengths and suction head heights.

Security – The sample compartment and control panel have a padlock feature, but the location may need additional security to prevent tampering or vandalism.

Accessibility – The sampler must be installed in a location where personnel can easily exchange bottles and perform routine service.

The sampler requires about 2600 square centimeters (925 in²) of floor space. Additional space must be allowed in front of the sampler, at its left and right sides, and above the sampler. Do not block access to these areas.

Obstructions will make routine servicing activities difficult or impossible.

The back of the sampler may be placed against a wall. Allow free air flow on both right and left sides of the sampler, particularly at the vents.

Unrestricted air flow behind and around the sampler will allow the refrigeration system to work efficiently.

Level Surface – The sampler should be placed on a level surface and the feet on the refrigerator body should be adjusted to prevent tipping or spills. If the sampler is not level, the sample liquid may miss the bottle mouth.

To level the sampler, place a bubble level on the top of the refrigerated compartment.

CAUTION

Do not tip the sampler on its side or back. Tipping the sampler more than 45° might cause oil to run into the compressor inlet, which can permanently damage the refrigeration system.

2.3 Connecting Power

WARNING

Before connecting the sampler to an AC power source, be familiar with the Electrical Requirements listed at the front of the Installation and Operation manual.

The factory assembles the sampler for either 115 VAC/60 Hz, or 230 VAC/50 Hz. The serial number label located inside the control cover identifies the AC power configuration of your sampler. You cannot convert the sampler in the field.

- The mains power cord for 115 VAC samplers is equipped with a NEMA 5-15P plug for standard North American outlets.
- The mains power cord for 230 VAC samplers is equipped with an EU 1-16P plug for standard CEE 7-7 European outlets.
- For other types of outlets that supply compatible AC power, convert the mains

power cord plug with a locally-purchased adapter.

Plug the mains power cord into the outlet. The sampler control panel will briefly show this start up display.

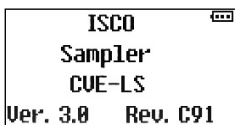

Note

The refrigeration system must sit for 24 hours before powering up. This allows the compressor oil to drain back into the compressor if the unit was tipped on its side any time during shipment or during installation.

2.4 Installing a Bottle Kit

The sampler can hold 1, 4, 12, and 24 bottles. Each of these bottle configurations are supplied as a kit (see Table 2-1), which is normally ordered with the sampler or when you desire to change the bottle configuration.

Table 2-1 Bottle Kits

Part Number	Description
602320001	24-bottle Configuration. Includes complete bottle rack with 24 polypropylene 1-liter wedge shaped bottles with caps and discharge tube.
602320003	4-bottle Configuration. Includes bottle rack with 4 polypropylene 15-liter wedge shaped bottles with caps.
602320002	12-bottle Configuration. Includes complete bottle rack with 12 polyethylene 2.5-liter wedge shaped bottles with caps and discharge tube.
682320026	1-bottle Configuration. Includes one polyethylene 3-gallon (11-liter) container, lid, and full bottle shutoff switch.
682320025	1-bottle Configuration. Includes one polyethylene 5-gallon (18.5-liter) container, lid, and full bottle shutoff switch.
299001306	1-bottle Configuration. Includes one polyethylene 5.5-gallon (20.5-liter) round bottle and cap.

Refer to the instructions for your selected bottle configuration:

- Bottle Configuration: 24-1L – Section 2.4.1
- Bottle Configuration: 4-15L – Section 2.4.2
- Bottle Configuration: 12-2.5L – Section 2.4.3

If you have selected a single (composite) bottle kit, refer to the instructions in Section 2.4.4.

For first-time use of the sampler, or if you have changed the bottle kit, be sure to configure the program for the new bottle kit (Section 3.3.2).

 **Note**

An incorrectly installed discharge tube can cause the sample to miss the bottle. Do not try to manually rotate the sequential table. This may damage the drive system.

2.4.1 24-1 Liter

The 24 bottle configurations use a rack to hold and align the containers. To install the bottles in the refrigerator using the rack:

1. Place the uncapped bottles into the rack.
Install bottle retaining ring and fasten with the 3 bungee cords.
2. Pull the sequential table forward. (Platinum only).
3. Locate the arrow in center of the rack and align it with the center block located on the turn table.
4. Roll the sequential table back into the sampler. (Platinum only).
5. Activate the program to RUN and the table will turn to locate #Bottle 1. After the table has stopped make sure the discharge tube is centered on the bottle. If the discharge tube is not centered, rotate/adjust the discharge tube to the center of the bottle.

Note

Bottle caps can be stored in the center of the bottle rack.

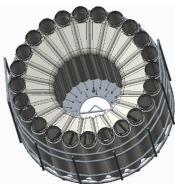

Figure 2-1 Bottle rack with 24-1 liter bottles

✓ Note

Align the arrow in the center of the rack with center block located on the table (Figure 2-2).

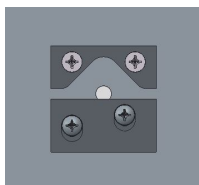

Figure 2-2 Locating center block

2.4.2 4-15 Liter (Platinum only).

To install the rack and bottles:

1. Pull the sequential table forward.
2. Place the four bottles on the sequential table using the alignment rack to position the bottles. Remove the bottle caps.
3. To load or unload the sample bottles there is a table jog feature. When the program is not in the run mode, the jog feature is available by pushing the 0 button on the keypad. The table will jog 90° each time 0 is pushed.
4. When the bottles are loaded, slide the sequential table back into place.

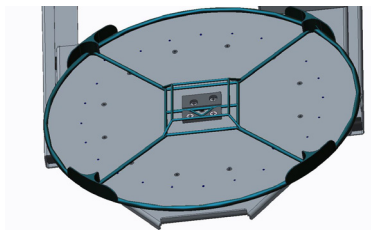

Figure 2-3 The 4-15 liter bottle rack

2.4.3 12-2.5 Liter

The 12 bottle configuration uses a rack to hold and align the bottles. To install the bottles into the sampler:

1. Place the uncapped bottles into the rack.
2. Roll the sequential drive out.
3. Locate the arrow in the center of the rack and align it with the center block located at the center of the drive table.
4. Roll the sequential table back into the refrigerated compartment.
5. Activate the program to RUN and the table will turn to locate #Bottle 1. After the table has stopped make sure the discharge tube is centered in the bottle. If the discharge tube is not centered, rotate/adjust the tube to the center of the bottle.

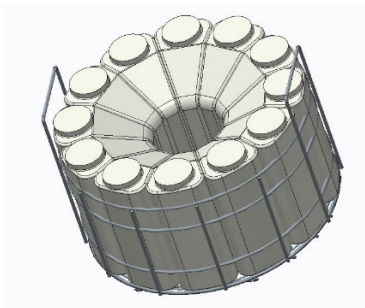

Figure 2-4 Bottle rack and 12-2.5 liter

2.4.4 Single Bottle Configuration

If your sampler is configured for composite sampling simply place the discharge tube in the center of the sample bottle.

Composite Bottle Installation

1. Install the discharge tube (if needed).
Remove bottle cap and position the bottle under the discharge tube.

<input checked="" type="checkbox"/> Note

Make sure the discharge does not contact the bottle in any way.

2. Go to BOTTLE Opt. in the menu and select COMPOSITE and then select your bottle size.

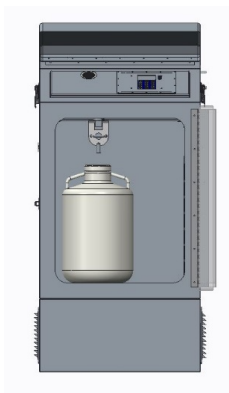

Figure 2-5 One 20 Liter PE Bottle

2.5 Attaching the Suction Line

Note

The suction line is the tubing from the sampling point to the sampler intake fitting. The sampler typically uses a $\frac{3}{8}$ inch ID (9 mm) suction line of lengths from 3 to 150 feet. Teledyne ISCO offers vinyl or PTFE-lined suction lines. The PTFE-lined tubing has a polyethylene jacket to protect it from kinks and abrasions. The vinyl suction line contains a very low parts-per-million level of phenols. If phenol content affects your sample analysis, use the PTFE-lined suction line.

Teledyne ISCO ships suction line in standard lengths of 3.0 m (10 ft) or 7.6 m (25 ft). Either length should be cut to the shortest length feasible for the installation. When installed, the line should run the shortest possible distance from the collection point to the sampler, preferably with a gradual upward slope. Excess suction line should be cut, not coiled. Coiled suction line will hold liquid between sample events which could cross-contaminate samples or freeze in cold climates. If the standard lengths are too short, or if you are cutting compatible $\frac{3}{8}$ inch ID suction line from a bulk spool, you can use lengths up to 45 m (150 ft).

2.5.1 Vinyl Suction Line

The sampler inlet fitting is on the left side of the samplers. $\frac{1}{2}$ " and $\frac{3}{8}$ " stainless steel barbed fittings are available to choose from. The sample line is $\frac{3}{8}$ " x $\frac{5}{8}$ " (I.D. x O.D.) or $\frac{1}{2}$ " and $\frac{3}{4}$ " clear PVC tubing which is connected to the a right-angle barbed fitting.

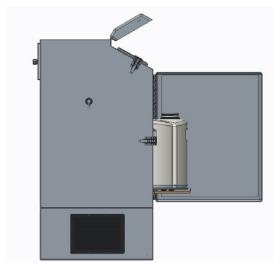

Figure 2-6 Left side of the sampler

2.5.2 PTFE-lined Suction Line

Inserting a tube coupler into PTFE-lined suction line will damage the thin lining. Instead, refer to Figure 2-7 and the instructions below to attach PTFE-lined suction line to the sample tube:

1. Slide a short piece of silicone tubing over the inlet fitting and install a hose clamp (B).
2. Push about 20 mm of the PTFE-lined suction line into the end of the silicone tube (A).
3. Slide the clamp over the union and tighten. Do not overtighten; this might cause the tubing to collapse or restrict the flow.

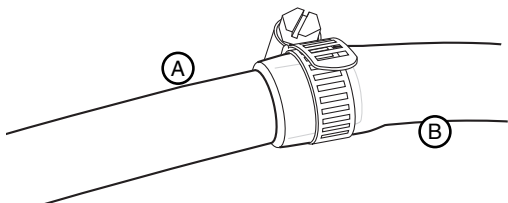

Figure 2-7 Connecting PTFE-lined suction line (A) silicone tube (B)

2.6 Attaching a Strainer

To select the right strainer for your application, refer to Figure 2-8 and the table that follows.

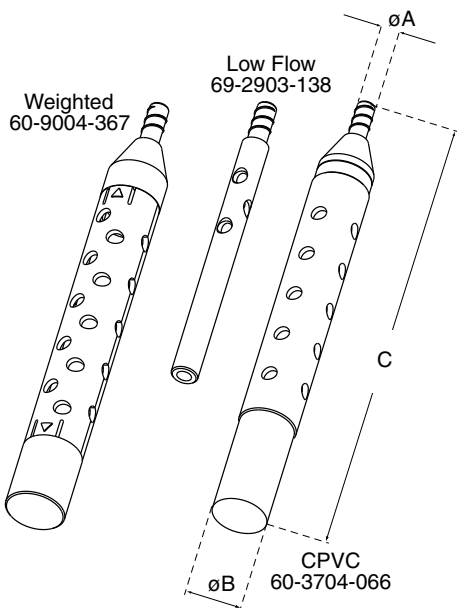

Figure 2-8 Strainers

To attach the strainer to the suction line, carefully screw the strainer's threaded connector into the suction line. If attaching the strainer to an PTFE-lined suction line, heat the suction line end before threading the strainer

into the line. Warming PTFE-lined tubing will make it more pliable to avoid damage.

2.6.1 Alternative to Strainers

When sampling from high velocity streams with heavy suspended solids, some field investigations suggest that more representative samples are obtained without the strainer. Consider attaching a short piece of thin walled aluminum tubing to the end of the suction line; anchor the tubing so that the inlet opens upstream. The aluminum tubing's thin wall will not disturb the flow stream, and most sample analyses disregard aluminum ions. Under most conditions, a pre-sample line rinse removes any debris over the tubing entrance.

2.6.2 Max Unanchored Length

During a pre or post-sample purge or line rinse, the suction line is filled with air which might cause the suction line and strainer to float. If the length of the suction line and strainer exceeds the listed value, securely anchor the strainer.

Even if the maximum length is not exceeded, it is a good idea to anchor the suction line and strainer when sampling from high velocity or turbulent flow streams.

2.7 Routing Suction Line and Strainer

Route the suction line so that it has a continuous slope from the liquid source to the sampler. This helps to drain the line during pre and post-sample line purges and rinses. If a suction line exposed to freezing climates does not fully drain, there is a risk of liquid in the suction line becoming frozen. Frozen liquid will cause the sample collection to fail. A warm sampling source can usually prevent this, provided there are no traps or low spots in the suction line. Some extreme situations may require more protective measures, such as insulating the suction line or applying heat tape or adding a pump heater.

For representative samples, place the strainer in the main current of the flow stream, not in an eddy or at the edge of flow. Placing a strainer at the bottom may produce samples with excess heavy solids and no floating materials, while placing it at the top may produce the opposite conditions.

2.8 External Devices

You can connect the sampler to an external instrument (Figure 2-9) for a variety of reasons. Typical reasons include:

- Receiving flow pulses from a flow meter device for variable time.

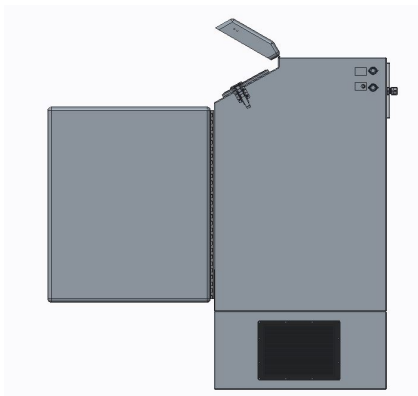

Figure 2-9 External device connections are located on the upper right side of the sampler

- Receiving an enable pin signal to enable sampler operation once site conditions warrant sample collection.
- Receiving a linear 4-20 mA analog or pulse representation of the flow rate for variable time.
- Sending alarm signals when sampling events occur.

These types of connections can be categorized as Standard ISCO device connections or other device connections. Each type is discussed in Sections 2.8.1.

2.8.1 Other Device Connections

You can connect the sampler to receive a 4-20 mA signal, 0-5 VDC, 0-10 VDC or pulses from an external device.

CAUTION

Risk of equipment damage. Only experienced electronic technicians should make the connections to an external device.

To connect the external device, refer to Table 2-2 and select the appropriate pins. Connect the wires by inserting the wires into the proper pin number and tightening them. To complete the connection, be sure to finish the connector assembly.

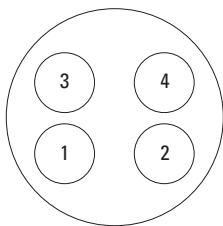

Analog Flow Signal
(4 pin connector)

Pin 3+

Pin 4-

Pulses (Dry Contacts)

Pin 1

Pin 2

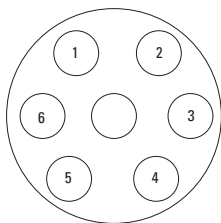

(7 pin connector)

1&2 Float

Start-Orange

3&4 Run Status-Blue

5&6 Alarm-Red

Table 2-2 Input Connector (4 pin)

Pin	Input Signal	Signal Name	Parameters/ Comments
1	Pulses	Dry Contact	Pulse input
2	Pulses	Dry Contact	Pulse input

Table 2-2 Input Connector (4 pin)

Pin	Input Signal	Signal Name	Parameters/ Comments
3	4-20 mA,0-5VD,0- 10VDC (+)	Analog	
4	4-20 mA,0-5VDC, 0-10VDC (-)	Analog	Input: Linear current loop signal representing minimum flow rate at 4 mA, maximum flow rate at 20 mA (0-5VDC) 0-Minimum 5-Maximum (0-10VDC) 0-Minimum 10-Maximum

Table 2-3 I/O Connector (7 pin)

Pin	Wire Color	Signal Name	Parameters/ Comments
1	Orange	Float Start or Float Start/Stop	Dry contact Closed contact to initialize program start or close contact to start program and open stops program
2	Orange	Float Start or Start/Stop	
3	Blue	Run Status	Dry contact Relay 250V 5 amp rated, closed contact during sample cycle
4	Blue	Run Status	
5	Red	Alarm	Dry contact Relay 250V 5 amp rated, closed contact during a fault condition or program done
6	Red	Alarm	

2.9 Configure and Program the Sampler

To complete the installation, the sampler software should be configured and programmed. Refer to Section 3 for programming instructions or Section 2.11 for the quick start guide.

Configure the sampler to make sure that it recognizes what bottle configuration is installed. Program the sampler to specify how and when the sampler should collect liquid samples.

2.10 Locking the Sampler

Locking the sampler is an optional step that can prevent tampering with the sampler operation or collected samples.

To prevent tampering with the sampler operation, the sampler has a PROGRAM LOCK. When enabled, this software feature requires a numeric password to access most of the control panel functions. Refer to Section 3.3.9 to enable this option.

To prevent tampering with the collected samples, place a padlock on the refrigerator door latch and control panel.

2.11 Quick Start Guide

2.11.1 Program Ready Screen

At initial power up, the controller displays the PROGRAM READY screen:

To run the displayed program, select F1 for RUN. Program timer begins and the program runs as specified.

- Select F1 to STOP the program at any point of the program running mode.
- Select F1 again to RESET the program and go back to the PGM READY screen.

To configure the program settings, select F3 for MENU. Use the arrows to the right of the display to scroll through the programs (1-6). Press F3, or SEL to select the program to configure.

- Optionally scroll through the PROGRAM CONFIGURATION (PGM CONFIG) menu using the arrow keys to select which program setting to configure. The following list displays all of the variable sub-settings within each program setting.

2.11.2 Program Configuration

Cycle: Set the sampling parameters here.

Prepurge: Enter the number of seconds (0-99) for the system to purge the intake lines prior to sampling. Then press F3 to accept.

Sample Seconds: The sample size is set with the adjustable intake tube. Set a sampling time duration that is long enough to allow time for the sample to fill the sample chamber and touch the liquid sensing electrodes. Test this and increase the time if no sample enters the chamber. Press F3 to accept.

Postpurge: Enter the number of seconds (10-99) for the system to purge the intake after the sample is taken. Press F3 to accept.

Num Rinses: Enter the number of times (0-4) the intake line should be rinsed, prior to each sample. Press F3 to accept. This option is to precondition the sample line before taking a sample.

Pressure Time: This menu item displays only if the Number of Rinses is not zero. Type in the number of seconds (0-99) each rinse should pressurize the sampler chamber.

Vacuum Time: Enter the number of seconds (0-99) each rinse should generate suction. The time should be short enough that the sample does not enter the sample chamber during the rinse. Press F3 to accept.

Recycle: Use up and down arrows to enable or disable the sample retry feature, or press F3 to accept the setting. When the recycle feature is enabled, the sampler makes a second attempt to take the sample, if it failed to collect a sample on the first try.

Consecutive SMPL: To draw just one sample per interval, type 1 and press F3 to accept.

2.11.3 Sample Interval

SMPL. Interval: Press F3 to select the SAMPLING INTERVAL setting. Use the up and down arrows to scroll through the options and select F3 to accept. Generally, the sampling interval is a set time, in between samples.

2.11.4 Time Option

Use the up or down arrow keys to scroll to the desired option (e.g. Time Fixed). Press F3 to accept.

SMPL Min: Use the keypad to enter the desired SAMPLING TIME INTERVAL or leave as is, then press F3 to accept.

2.11.5 Bottle Options

Sample Type: Use arrows to scroll and press F3 to select COMPOSITE or DISCRETE/SEQUENTIAL SAMPLING type.

- If DISCRETE SAMPLE TYPE was selected, the next menu is BOTTLE CONFIG. Use the arrows to scroll to the desired bottle configuration that is installed in the sampler, then press F3 to select.

Num. Bottles: Enter the number of bottles that you want to use, otherwise press F3 to accept the default setting to use all the bottles.

SAMPLS/Bottle: Enter the number of samples that you want to collect in every bottle. Then press F3 to accept this setting. Be sure to not overfill the sample bottles.

Index Type: Use the arrows to scroll to the desired indexing type. The AFTER BOTTLE setting is defaulted, which tells the program to rotate to the next bottle, once all of the specified samples are discharged into the current bottle. Press F3 to accept this setting.

After entering these settings, the screen will return to the PGM CONFIG menu, indicating that the program setup is complete. If you do not wish to enable any PROGRAM RUN OPTIONS (see manual for more detail), press F1 twice to return to the PROGRAM READY screen.

Platinum/Optima CVE Refrigerated Sampler

Section 3 Programming

3.1 Control Panel Description



Figure 3-1 Control Panel

Table 3-1 Control Buttons

Icon	Name	Description
F1	HOME RUN STOP RESET ESC YES	Go to home screen Start the program Stop the program Reset the program Go back to previous menu Accept
F2	MAN TIMED GRAB BACK MORE	Manual sample Set a timed delay Grab sample Go back in the program See more detail in log file
F3	MENU SEL PAUSE RESTART START DETAIL CONTINUE NO	Go to menu Select Pause the program Restart a program Initiate sample View log detail Continue program Reject
Back		Press this button to back one space when entering a number.
Enter		Press this button to back one space when entering a number.
0-9	Keypad	Keypad enter numbers

3.2 Getting Started

Apply power to the sampler (see Section 2.8). The start-up screens appear on the LCD display.

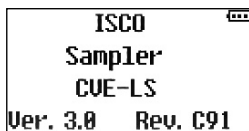

```
ISCO
Sampler
CUE-LS
Ver. 3.8 Rev. C91
```

Note

The refrigeration system may need to sit 24 hours before starting if the unit was tipped upside down during shipment or installation. This will allow the oil in the compressor to drain back.

After installing the sampler plug the power cord into the proper receptacle. The display will light up and programming can begin. The program is ready to be configured.

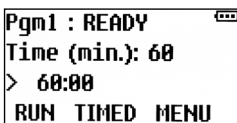

```
Pgm1 : READY
Time (min.): 60
> 60:00
RUN TIMED MENU
```

Pgm 1: Ready: This screen displays three menu options appear RUN TIMED MENU.

If you have just installed the sampler, you will first need to program the sampler (Section 3.5). To program the sampler:

1. Pushing F3 located under MENU will advance the program to MAIN MENU.
2. Go to PROGRAM menu. Pushing F3 the menu advances to PGM SELECT PROGRAM 1).
3. Press SELECT to enter the PGM SELECT menu.

This part of the menu will allow you to make changes to the program.

- Cycle (Sampling settings)
- Smpl. Interval (Timed or Flow intervals)
- Bottles Opts. (Composite or Discrete)
- Pgm. Run Opts. (Run Options)
- Pgm. Events (Scheduled Events)

3.3 Configuring the Sampler

Before operating the sampler, configure the sampler software. Doing so will set the time and date, allow the sampler controller to correctly use the hardware.

To begin from PGM1: READY

1. Press the Menu(F3) button, the screen will advance to MAIN MENU > PROGRAM MENU press SEL(F3).
2. The next screen is PGM SELECT > PROGRAM #1 push SEL(F3) the screen advances to PGM CONFIG >CYCLE. In this configuration you set the parameters.

You can step through the parameters using the SEL(F3) button. If a change was made to the

program push SEL(F3) to enter the change or to scroll thru the settings.

To return to the PGM1: READY screen, push HOME(F1) two or three times depending where you are in the program.

3.3.1 Set Clock

To set the clock:

1. Scroll to ADMIN. MENU push SEL(F3) and scroll until you see >SET DST and push F3(SEL). Use the up and down arrow to scroll winter/summer.
2. Then push SEL(F3) to select.

Setting the time and date allow the sampler controller to correctly use the hardware. There is an option to set the time for daylight saving time (winter or summer).



```
ADMIN MENU ...  
Use ↑↓ to select  
>Set Clock  
HOME   BACK   SEL
```

```
CURRENT DATE ...  
mm/dd/yy ↑↓  
07/24/18  
ESC   ←   →
```

```
CURRENT TIME ...  
hh:mm:ss ↑↓  
09:38:57  
ESC   ←   →
```

Press the number buttons to type the current date and hours (using 24-hour format). Press ENTER to accept the date and move to time. When finished the screen will advance to ADJUST LCD screen.

3.3.2 Bottle Configuration

Select this option to specify the installed bottle configuration (Section 2.3). The sampler uses this setting to determine available bottle options and control the operation of the indexing table.

1.

```
PGM CONFIG ...  
Use ↑↓ to select  
>Bottle Opts.  
HOME   BACK   SEL
```

To select the bottle configuration press ENTER or SEL(F3).

2.

```
SAMPLE TYPE ...
Use ↑↓ to select
>Composite
HOME    BACK    SEL
```

```
SAMPLE TYPE ...
Use ↑↓ to select
>Discrete
HOME    BACK    SEL
```

To select COMPOSITE or DISCRETE sampling use up or down arrow and push SEL(F3).

```
COMP. SIZE ...
Use ↑↓ to select
>1 gal.
HOME    BACK    SEL
```

Composite

```
BOTTLE CONFIG. ...
Use ↑↓ to select
>24 1 L
HOME    BACK    SEL
```

Discrete

When the bottle and sample size is set, make sure not to overfill the bottles.

3.3.3 Suction Line

The intake tubing length is not entered into the program. The sample time is set long enough for the sample chamber to fill and the liquid to touch the liquid sensor.

3.3.4 Rinse Cycle

You can use RINSE CYCLES to condition the suction line and strainer before collecting a sample. RINSE CYCLES may also improve sample volume repeatability by ensuring the suction line is wetted before each sample.

The rinse setting is located in the CYCLE MENU after post purge. The maximum rinse cycles and recycles is 4.

```
NUM. RINSES ☰
(0-4)
> 0_
HOME    BACK    SEL
```

- 0 turns the Rinse cycle option OFF.
- 1-4 Number of Rinses activates the option:

```
VACUUM TIME ☰
(0-99 sec.)
> 6_
UNDO    BACK    SEL
```

- Enter RINSE VACUUM time. Be sure that the vacuum cycle does not allow the fluid to pump into the sample chamber. Test and adjust the vacuum time as necessary.

```

PRESSURE TIME ☰
(0-99 sec.)
> 8_
UNDO   BACK   SEL

```

- Enter RINSE PRESSURE time. Pressure time should be at minimum the entered vacuum time.



WARNING

During the rinse cycle if the sample enters the sample chamber and reaches the liquid-sensor electrodes, the program will stop the vacuum time and switch to purge.

3.3.5 Liquid Detector and Recycle

The liquid sensor electrodes are mounted at the top of the sample chamber lid. If the sample does not touch the electrodes, then SAMPLE FAILED will appear and RECYCLED will activate if programmed. The liquid detection feature is always on. The RINSE and RECYCLE option is located in the CYCLE MENU after post purge. The maximum number of rinse and recycle cycles is four.

```

RECYCLE ☰
Toggle ⬆️⬆️
OFF
HOME   BACK   SEL

```

Turn recycle on or off using the arrow keys

ON: If the sampler fails to detect liquid, it will try again up 4 times to collect the sample.

3.3.6 Float Input

Depending if the FLOAT INPUT options have been factory-configured, enabling this input will configure the sampling program to delay sample collection until that circuit closes and subsequently either:

- **Float Start:** continue sampling even if the float circuit reopens,
- **Float Start/Stop:** toggle the collection of samples on and off as the rising and falling stream level closes and opens that circuit. This feature may be used with full bottle shut off for composite samples.

FLOAT INPUT		Toggle to change
Toggle ⬆️		Disable/ Enable
Disable		and press Enter.
HOME BACK SEL		If Disable the option
		is turned off.

The sampler controller is **DISABLED** when pins 1 and 2 are open of the external 7 pin connector (orange wires). The controller is **ENABLED** when pins 1 and 2 are closed.

3.3.7 Output Pins

An alarm output is based one of the following events:

- **Program Done:** This event occurs when a running sampling program has finished

or full bottle. This alarm output stays on as long as the run time display reads PGM: DONE.

- **Recycle:** The collection of incomplete samples by repeating the sampling cycle as many as four times. To enable or disable it.
- **Temperature Error:** The temperature has been above its set temperature for more than 30 minutes.
- **Failed Sample:** This event occurs when the sampler failed to reach the liquid-sensor electrodes. This may occur if the intake line is plugged or the vacuum time may need to be increased.
- **Indexing Error:** This event occurs when the turntable has an indexing failure. This condition must be corrected before the sampling program can resume. This alarm output stays on until the condition is corrected.

(Alarm- 7 pin output connector using 2 red wires pins 5 & 6.)

- **Run Status:** This event occurs each time a sample is taken. The output stays on until the sample event is completed.
(2 blue wires pins 3&4)

- **Float Start or Float Start/Stop:**

*Float Start- If the FLT START setting is selected, the program will start with a closed contact and the program will continue

sampling without interruption even if that circuit reopens.

*Float Start/Stop- If the FLT START/STOP setting is selected, the program will reset its sampling interval counters and not restart them until the float circuit closes again (i.e., those counters will restart from zero when the water level rises high enough to close the float switch).

 **Note**

The full bottle switch uses the float start/stop feature. If float start or start/stop is being used as a remote start the full bottle switch cannot be used.

3.3.8 Refrigeration

The sampler will display the interior cabinet temperature. Scroll thru the run displays to locate the temperature.

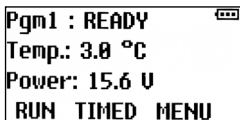

```
Pgm1 : READY
Temp.: 3.8 °C
Power: 15.6 U
RUN TIMED MENU
```

Setting the Refrigerator Temperature: The thermostat is located on the lower right side of the refrigeration module. Remove the air vent to adjust the temperature by using the up and down arrow on the display. To set the temperature output 1 for refrigeration and output 2 for the heater.



3.3.9 Program Lock

Select this option to turn the PROGRAM LOCK feature on or off, and to change the password. When this security feature is enabled, the sampler requires a numeric password before a user can configure the program.

```
ADMIN MENU ☰  
Use ⬆ to select  
>Set Password  
HOME    BACK    SEL
```

The program protection is OFF when the password is set to zero.

```
SET PASSWORD ☰  
(0-99999999)  
> 56_  
UNDO   BACK   SEL
```

```
ADMIN MENU ☰  
Use ↑↓ to select  
>Clr Password  
HOME   BACK   SEL
```



WARNING

DO NOT FORGET THE PASSWORD!

Should you forget the password, contact ISCO's Customer Service department for assistance.

3.3.10 Language Selection

Select this option to change the display language.

1.

```
ADMIN MENU ☰  
Use ↑↓ to select  
>Set Language  
HOME   BACK   SEL
```

Press SEL(F3) or ENTER

2.

```
LANGUAGE ☰  
Use ↑↓ to select  
>German  
HOME   BACK   SEL
```

Scroll using the up and down arrow to select a language (English, German, French, Spanish, Italian, Polish, Danish, Swedish).

Press SEL (F3) or ENTER.

3.

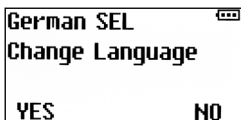

```
German SEL ***
Change Language
YES          NO
```

If the language is correct at the top of the screen press YES, if it is wrong press NO. If NO was selected the language did not change.

3.3.11 Set Unit ID

Each sampler can be assigned a unique ID number that will be included in its archival data files.

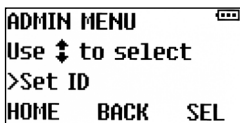

```
ADMIN MENU ***
Use ↑↓ to select
>Set ID
HOME  BACK  SEL
```

Press SEL(F3)

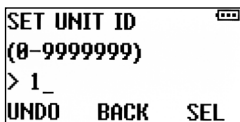

```
SET UNIT ID ***
(0-9999999)
> 1_
UNDO  BACK  SEL
```

3.3.12 Diagnostics

Each time a sample is taken, the program checks the bottle location when in the sequential sampling mode.

3.3.13 Exit Configuration

Pressing HOME (F1) the program will exit the PROGRAM menu and return to PGM: READY. Depending on what part of the PROGRAM menu you are in it may take 2 or 3 times to exit the PROGRAM menu completely.

3.4 Sampling Program Overview

The sampling program controls how often sample events occur and what should take place at each event. A sample event may happen when:

- Starting a flow paced program that is programmed to sample after a delay (Section 3.5.13).
- A time paced program reaches the first sample time and date.
- The programmed time interval has elapsed.
- The programmed number of flow pulses has been reached.

At each event, the sampler:

1. Resets the programmed flow or time pacing interval after initializing a sample.
2. Purges the suction line (see Section 3.3.3).

3. Sends a closed contact while sample is taken. The sampler deposits the programmed sample volume into the bottle. If programmed to deposit a sample volume in more than one bottle, the sampler:
 - a. Moves the table to the next bottle.
 - b. Deposits the programmed sample volume into the bottle.
 - c. Repeats steps 3a and 3b until the programmed number of bottles per event is reached.

4. Purges the suction line (see Section 3.3.3). There are five categories of sampling program instructions that control the above actions in an event. These categories include:

- **Cycle:** Parameters that configure the sampling cycle, purge, sample time, post purge, rinse, recycle, and consecutive samples.
- **Sample Interval:** Define what controls the sample collection interval based on Time or Flow.
- **Bottle Option:** Define which sampling type (discrete/composite) and the bottle configuration.
- **PGM Run Options:** Configure program run options including auto rerun, delay start, float, fault, timed stop, and bottle limit.

- **Program Events:** Configure scheduled events that start, stop, pause, halt, and resume the program.

3.4.1 Program Configuration

The following are the Program setup categories and their related programming screens:

```
MAIN MENU ☰  
Use ↑↓ to select  
>Program Menu  
HOME   BACK   SEL
```

Press F3/SEL
to advance

```
PGM SELECT ☰  
Use ↑↓ to select  
>Program #1  
HOME   BACK   SEL
```

Press F3/SEL
to advance

3.4.2 Sampling Cycle

```
PGM CONFIG ☰  
Use ↑↓ to select  
>Cycle  
HOME   BACK   SEL
```

Press F3/SEL

```
PREPURGE ☰  
0-99 sec.)  
> 20_  
UNDO   BACK   SEL
```

Press F3/SEL

```

SMPL SECONDS
(1-200) sec.
> 15_
UNDO  BACK  SEL

```

Press F3/SEL

```

POSTPURGE
(10-99 sec.)
> 10_
HOME  BACK  SEL

```

Press F3/SEL

```

NUM. RINSES
(0-4)
> 0_
UNDO  BACK  SEL

```

Press F3/SEL

If Rinse is 0 program
advances to Recycle



```

PRESSURE TIME
(0-99 sec.)
> 2_
UNDO  BACK  SEL

```

```

VACUUM TIME
(0-99 sec.)
> 2_
UNDO  BACK  SEL

```

```
RECYCLE ☰  
Toggle  $\updownarrow$   
OFF  
HOME   BACK   SEL
```

Press F3/SEL

```
RECYCLE ☰  
Toggle  $\updownarrow$   
ON  
HOME   BACK   SEL
```

Press F3/SEL

```
CONS. SAMPLES ☰  
(1-24 samples)  
> 1_  
HOME   BACK   SEL
```

Press F3/SEL

```
PGM CONFIG ☰  
Use  $\updownarrow$  to select  
>Smpl. Interval  
HOME   BACK   SEL
```

Press F3/SEL

3.4.3 Sample Interval

```

SMPL. INTERVAL ☐☐☐
Use ↑↓ to select
>Time
HOME   BACK   SEL

```

Or

```

SMPL. INTERVAL ☐☐☐
Use ↑↓ to select
>Flow
HOME   BACK   SEL

```

Press F3 (SEL) to enter the programmed value and to advance to the next screen

```

TIME OPTION ☐☐☐
Use ↑↓ to select
>Time Fixed
HOME   BACK   SEL

```

```

FLOW OPTIONS ☐☐☐
Use ↑↓ to select
>Pulses
HOME   BACK   SEL

```

```

SMPL. MIN. ☐☐☐
(1-9999)
> 30_
UNDO   BACK   SEL

```

```

FLOW OPTION ☐☐☐
Use ↑↓ to select
>Pulses Fixed
HOME   BACK   SEL

```

```

SMPL. PULSES ☐☐☐
(1-9999)
> 320_
UNDO   BACK   SEL

```

3.4.4 Bottle Configuration

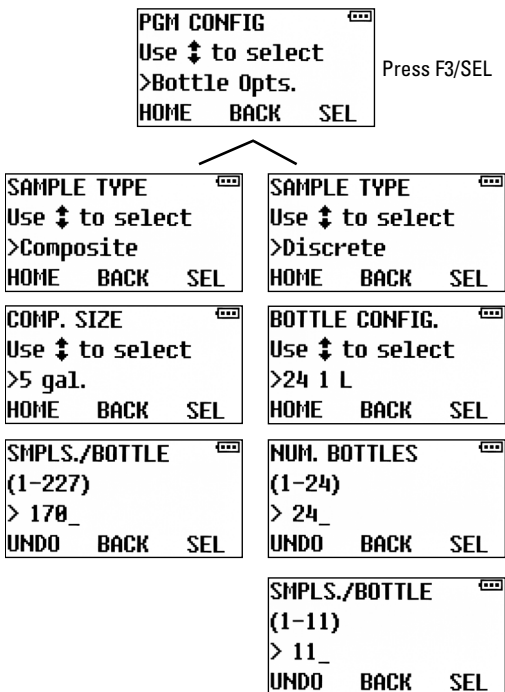

```
INDEX TYPE ☰  
Use ↓ to select  
>After Bottle  
HOME    BACK    SEL
```

The INDEX TYPE can be configured to rotate to the next bottle using the following indexing criteria:

- **AFTER BOTTLE**- The table will advance after the bottle is serviced. If each bottle was to receive 3 samples per bottle the table would advance after the 3rd sample in each bottle.
- **AFTER SAMPLE**- The table advances after each sample. If the program was for 2 samples per bottle and turn after the sample, the table would make two full revolutions.
- **AFTER TIME**- The turntable rotates each time a specified indexing interval elapses.
- **REAL TIME**- The turntable rotates at a fixed duration intervals stating at a specified time of day.

3.4.5 Program Run Options

```
PGM CONFIG ☰  
Use ↑↓ to select  
>Pgm. Run Opts.  
HOME   BACK   SEL
```

Press F3/SEL

- **AUTO RERUN**-If you configure a Start Event to repeatedly start and stop the sampler, enabling the Automatic Rerun parameter will allow the program to restart without having to reset.

```
AUTO RERUN ☰  
Toggle ↑↓  
Disable  
HOME   BACK   SEL
```

- **FAULT OPTION**- Enable turns the Fault Option ON. The alarm condition displays the Alarm Icons, and also energizes a relay, if a fault condition is detected.
-**TEMPERATURE OPTION** - If the Fault Option is Enabled, the Temperature Fault option is displayed. This feature enables an alarm when the enclosure temperature is out of spec for more than 30 minutes. Toggle between Enable or Disable.

```
FAULT OPTION ☰  
Toggle ↑↓  
Disable  
HOME   BACK   SEL
```

- **DELAYED START**- The program start time can be delayed in minutes.

```
DELAY START ☰  
(0-9999 min.)  
> 3600_  
UNDO   BACK   SEL
```

- **FLOAT INPUT**- Enable turns the Float option ON. Refer to the manual for more details.

```
FLOAT INPUT ☰  
Toggle ↕  
Disable  
HOME   BACK   SEL
```

- **TIMED STOP**- This parameter configures the program to automatically stop a specified number of hours or minutes after program start. Select: None, 24 Hour, 12 Hour, 8 Hour or Custom.

```
TIMED STOP ☰  
Use ↕ to select  
>None  
HOME   BACK   SEL
```

- BOTTLE LIMIT:

-**Program Stop:** after discharging a specific number of samples into a container the program stops and will have to be reset.

-**Program Continue:** the program will draw samples indefinitely. You must replace bottles as the program runs, to avoid bottle overflow.

```
BOTTLE LIMIT ☰  
Toggle ⬆⬇  
Pgm Stop  
HOME    BACK    SEL
```

```
BOTTLE LIMIT ☰  
Toggle ⬆⬇  
Pgm Continue  
HOME    BACK    SEL
```

3.4.6 Program Events

<pre> PGM CONFIG Use ↑↓ to select >Pgm. Events HOME BACK SEL </pre>	
<pre> PGM. EVENT #1 Use ↑↓ to select >Start Time HOME BACK SEL </pre>	<pre> PGM. EVENT #2 Use ↑↓ to select >Stop Time HOME BACK SEL </pre>
<pre> WEEKDAYS #1 SMTWTFS ↑↓ _●●●●● ESC ← → </pre>	<pre> WEEKDAYS #2 SMTWTFS ↑↓ _ ESC ← → </pre>
<pre> EVENT TIME #1 hh:mm:ss ↑↓ 14:00:00 ESC ← → </pre>	<pre> EVENT TIME #2 hh:mm:ss ↑↓ 18:00:00 ESC ← → </pre>
<pre> PGM. EVENT #3 Use ↑↓ to select >End List HOME BACK SEL </pre>	

Each program's scheduled events are defined by a list that can be accessed via the PROGRAM EVENTS group. Each event on that list has three associated values:

- The type of event (start, stop, pause, halt, resume or manually sample).
- The days of the week on which the event will be executed.

- The time of day on those days at which the event will be initiated.

Select the “End List” event when you have programmed all the desired program events. You can remove events by disabling the event for each day of the week.

3.5 Programming Steps

To begin programming from the PGM READY screen, use the menu F3 (SEL) button to select PROGRAM. Press the F3 button to display the first programming screen PROGRAM #1.

3.5.1 Sample Pacing

There are two pacing methods for sampling programs, Time Paced and Flow Paced.

- **Time Paced** sampling programs use the sampler’s internal clock to collect samples at a constant time or variable time interval. When you program the sampler for time pacing, the sampler will prompt you to enter the time between sample events in minutes.
- **Flow Paced** sampling programs require an electronic signal from a flow measurement device. This electronic signal is typically a dry contact (pulse) that indicates some user-programmed volume interval has passed through the flow channel. Because each pulse represents a volume interval, flow pacing rates are proportional to the volume of

water flowing through the channel. This is sometimes called “Constant Volume Variable Time (CVVT) sampling.” When you program the sampler for flow pacing, the sampler will prompt you to enter the number of pulses to count before collecting a sample.

All Teledyne ISCO flow meters provide a compatible flow pulse. Non-ISCO flow measurement devices may be used to paced the sampler. Refer to Section 2.8– External Devices for more details.

Use the F3(SEL) button to select the time or flow option, then press the ENTER button.

3.5.2 Time Paced

Time Paced Only – Use the number buttons to enter the time interval in minutes. The sampler collects a sample each time this interval elapses while the program is running.

3.5.3 Flow Paced

Flow Paced Only – Use the number buttons to enter the flow interval as a number of pulses. While the program is running the sampler counts the flow pulses until this number is reached. At this time the sampler collects a sample and resets the interval to begin counting again.

The volume that each flow pulse represents is a fixed volume. Refer to the instruction manual of the flow measurement device.

For example, consider an ISCO 4250 Flow Meter programmed to send a flow pulse every 100 gallons. If you are required to collect a sample every 10,000 gallons, you would enter 100 flow pulses. $10,000 \text{ gallons} \div 100 \text{ gallons} = 100 \text{ pulses}$.

If the flow measurement device sends flow rate data via a 4-20 mA current loop instead of flow pulses. The sample program needs to be changed in the SMPL. INTERVAL menu. The sampler assumes that the current is linear from 4 mA at zero flow to 20 mA at the full-scale flow rate.

1. Select the flow input type to 4-20mA.
2. Enter the maximum flow rate (MAX. LPM).
3. Enter the liters between each sample (SMPL LITERS).

Example: Consider a flow meter output to 20 mA at 1,000 liters per minute, the peak flow rate of the channel. If you are required to collect a sample every 5,000 liters, you would enter 5,000 in the SMPL. LITERS menu. The sampler would totalize the flow base on the MAX LPM and the flow signal. The sampler will totalize the liters based on the flow signal. There are no flow calculations needed, the sampler does that for you.

3.5.4 Bottles per Sample Event

Multiple Bottles Only – The sampler places a sample volume in one bottle or sets of bottles at each sample event. Use this screen to enter the

number of bottles to repeat the sample volume at each sample event. The effect of this number is illustrated below.

Distribution scheme with one bottle per sample event. Samples events are numbered.



Distribution scheme with two bottles per sample event.



Distribution scheme with three bottles per sample event.



3.5.5 Switch on Time Indexing

Multiple Bottles Only – The sampler can switch bottles at regular time intervals. Use timed indexing to switch Bottles/Sets based on time.

Multiple Bottles Only – If you selected Switch on Time, use the number buttons to enter the desired time interval for bottle set switches.

3.5.6 Real Time Indexing

Flow Paced, Multiple Bottles Only – If you are switching bottles by time intervals, use this

screen to specify the first switch time. All other bottle or bottle set switches will be relative to this time. Press the number buttons to enter the time of day in 24-hour format.

3.5.7 Samples Per Bottle

Multiple Bottles Only – The sampler places a sample volume from one or more sample events in a bottle. Use this screen to enter the number of samples to be placed in a bottle. The following diagrams illustrate the effect of this number.

Distribution scheme with one sample per bottle
Sample events are numbered.



Distribution scheme with two samples per bottle.



Distribution scheme with three samples per bottle



This SAMPLES PER BOTTLE feature can be combined with the BOTTLES PER SAMPLE EVENT (Section 3.5.4) to build more complex distribution schemes, sometimes known as

multiple bottle compositing. The following illustrates this example:

Distribution scheme with three bottles per sample event and three samples per bottle. Sample events are numbered

3	3	3	6	6	6
2	2	2	5	5	5
1	1	1	4	4	4

3.5.8 Run Continuously

Sample programs can run indefinitely or stop by going to PGM RUN OPTS and then to BOTTLE LIMIT. Select PGM. CONTINUE to run the program continuously or PGM STOP to stop the program when complete. Continuous sampling resets the distribution when the distribution sequence is complete. That is, when the last bottle/set is reached, the next bottle/set is the first bottle/set.

In this mode, the sampler assumes that any filled bottles are replaced and ready to receive samples while the program is running, thus the pacing interval is never interrupted.

If you select PGM STOP, the sampler will run until it completes the distribution sequence, at which time it stops the program and reports PROGRAM DONE. The sampler will wait in this state until the bottles have been emptied and the program is restarted.

If your sampler is configured for composite sampling, refer to Section 3.5.14 for instructions on continuous sampling.

3.5.9 Sample Second

Enter the number of seconds it will take to fill the sample chamber and touch the liquid-sensor electrodes. The sample seconds must exceed the number of seconds to fill the chamber. When the liquid-sensor is activated, the timer stops and the program goes to post purge.

3.5.10 Flow Pulses, Analog Input

Time Paced Only – If you are collecting sample volumes dependent on flow (Section 3.5.11), select which type of flow rate input is provided by the external flow measurement device (see Section 2.8).

3.5.11 Composite Samples

Single Bottle Only – Use the number buttons to type the number of composite samples to take. Press the ENTER button to accept the value.

The sampler does not calculate the maximum number of samples. Use caution when selecting the maximum number of samples per bottle so they do not overflow.

- If you selected continuous in the BOTTLE LIMIT menu, the sampler collects samples without regard for the total number of samples.
- If you enter continuous, keep in mind that the sampler might overflow the bottle.

- If you enter STOP, the program will stop when the program is done.
- The full bottle switch stops the sampler from taking samples when the container is full.

3.5.12 Pressurized Line

This sampler cannot be used in applications that collect samples from a pressurized line, without the pressurized line option. Attempting this will fill the sampler with water and void warranty. Teledyne ISCO offers a pressurized line option for the sampler. Contact the factory for more information.

3.5.13 Timed Delay

At this screen you have the option to start the sampling program immediately when you press the (F1) RUN PROGRAM button, or delay the sampling program until user-defined start time is met.

To program the sampler to start immediately, in the DELAY START menu enter 0. To enter a program delay enter the desired minutes that you want to delay the program from starting.

To set a start time and date can be made in two different locations:

PMG Ready Screen:

On the PGM READY screen push the F2 button labeled TIMED. The screen will advance to START TIME and enter the M/D/Y the program to start and the screen will advance to START

TIME to enter the time to start the program
H:M:S. Push the ENTER button after making
each selection.

```
Pgm1 : READY ...  
Time (min.): 60  
> 60:00  
RUN TIMED MENU
```

PMG Events:

Go to PGM EVENTS and to START TIME and then push SELECT. Enter the days of the week that you want the sampler to start by pushing the up or down arrow to highlight the day to start the screen will advance to EVENT TIME #1 enter the H:M:S to start the sampler. The sampler can do weekly start and stop PGM READY screen push the F2 button labeled TIMED. The screen will advance to START TIME and enter the M/D/Y the program to start and the screen will advance to START TIME to enter the time to start the program h:m:s. Push the ENTER button after making each selection.

```
PGM CONFIG ...  
Use ↑ ↓ to select  
>Pgm. Events  
HOME BACK SEL
```

Go to PGM EVENTS and to START TIME and push SELECT. Enter the days of the week that you want the sampler to start by pushing the up or down arrow to highlight the day to start The screen will advance to EVENT TIME#1 enter

the H:M:S to start the sampler. The sampler can do weekly start and stop sampling with pause and resume also. If the program is going to run on a weekly basis, then set the AUTO RE-RUN to ENABLE.

3.5.14 Auto Re-Run

By default, the sampling program must be manually reset each time it stops, which indicates to the controller that the sample containers have been emptied. If you configure a START EVENT to repeatedly start and stop the sampler, enabling the AUTOMATIC RERUN parameter would enable the program to restart without being reset.

Note

You should not enable this parameter unless you are scheduling automatic start events.

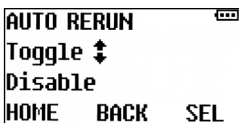

3.5.15 Timed Stop/Max Run Time

This parameter configures the program to automatically stop a specified number of hours or minutes after it initiates its interval timers. The choices are None, 24 HR, 12 HR, 8HR and Custom. The custom feature allows you to enter a shut of value that is not already in the program.

```
TIMED STOP ...  
Use  $\updownarrow$  to select  
>None  
HOME    BACK    SEL
```

```
TIMED STOP ...  
Use  $\updownarrow$  to select  
>24 Hour  
HOME    BACK    SEL
```

```
TIMED STOP ...  
Use  $\updownarrow$  to select  
>12 Hour  
HOME    BACK    SEL
```

```
TIMED STOP ...  
Use  $\updownarrow$  to select  
>8 Hour  
HOME    BACK    SEL
```

```
TIMED STOP ...  
Use  $\updownarrow$  to select  
>Custom  
HOME    BACK    SEL
```

```
STOP TIME ...  
(0-9999 min.)  
> 480_  
HOME    BACK    SEL
```

This feature is useful for applications that require the collection of a total sample volume proportional to the flow volume over a specific duration. An example of this would be a flow-weighted composite sample representative of the total daily flow volume (24 hours). If the application does not limit the sample collection to a specific duration, enter none.

Platinum/Optima CVE Refrigerated Sampler

Section 4 Operation

This section describes how to operate the sampler. These instructions assume that the sampler has been correctly installed (Section 2), configured, and programmed (Section 3).

4.1 Start a Sampler Program

Before starting a program:

- Verify the sample tube is connected to the sample.
- Place empty bottles in the rack and install on the sequential drive table.

To start the program from the READY screen, press the F1 RUN button. Upon initial setup, the sampler will need to be calibrated (See Section 4.1.1) to ensure volume accuracy.

If a sampler configured for multiple bottles was previously stopped (see Section 4.2), the sampler will rotate the bottles to number 1 position upon starting.

```
Pgm1 : READY
Time (min.): 60
> 60:00
RUN TIMED MENU
```

```
Pgm1 : RUNNING
Time (min.): 60
> 59:28
STOP MAN PAUSE
```

4.1.1 Sample Calibration

There are two ways to calibrate the sample:

1. To properly calibrate the volume prior to running a program, you must go to MAIN MENU and scroll to find the CALIBRATE menu item. Press F3 SEL to select the calibration menu item.
 - Calibrate #1 is displayed. Adjust the intake tube to set the sample size:
 - a. Loosen the compression nut and slide the tube down for a smaller sample and up for more sample.
 - b. Tighten the compression nut.
 - c. Start (F3) to collect the Calibration #1 sample.
 - d. Check for volume accuracy, then discard the sample and proceed to Calibrate #2 if necessary.
 - e. When the volume accuracy is acceptable, discard the calibration sample and press HOME (F1) to go to PROGRAM READY screen.
2. If you skip the calibration steps, the sampler will need to be calibrated in the RUN mode or GRAB mode.

4.1.2 Start Time Delay

If the program is set for NO DELAY TO START (Section 3.5.13), the sampler immediately begins to operate according to its CONFIGURE and PROGRAM settings.

If the program is set to use a start time, the sampler will wait for the specified time and date. During this delay, the display shows the current time/date and program delay time/date.

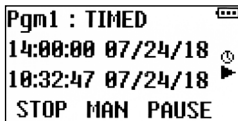

```
Pgm1 : TIMED
14:00:00 07/24/18
10:32:47 07/24/18
STOP MAN PAUSE
```

When the programmed start time and date match the sampler's time and date, the sampler program begins to run.

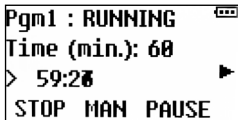

```
Pgm1 : RUNNING
Time (min.): 60
> 59:26
STOP MAN PAUSE
```

4.1.3 The Run State

Because the sampler operation is fully automated, no user intervention is required. Should there be a need to check on the running program, you can view the sampler display. It always reports the current state or operation and the refrigerator temperature.

Typically, the display will count to the next sample event. This screen may alternate with other messages:

1. If the sampler is disabled by an external device, the display will show FLT. START



2. If the sampler is currently taking a sample the display will show the pre-purge screen.
3. If the sampler has encountered error conditions during the running program, the display will show ERRORS HAVE OCCURRED and the alarm icon will show in the upper right of the display, if the alarm function is enabled.



4. If the sampler is programmed for TIMED indexing the bottles (Section 3.5.5), the display will show INDEX## min.:
- If any programmed sampler operations are based on the sampler's internal clock, the display will show the current time and date.

4.1.4 Completed Program

When the program is complete, the display will show PROGRAM DONE and number of samples can be viewed by scrolling through the run displays using the arrow keys.

If the sampler encounters an error at any time during the running program, an error message

will appear along with the alarm icon if enabled. See Table 4-1.

4.2 Pause or Stop a Running Program

Press F3 PAUSE button to pause a running program. The sampler will display:

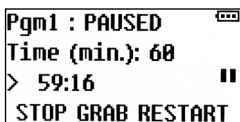

The screenshot shows a rectangular display with a black background and white text. The text is as follows:
Pgm1 : PAUSED (with a small icon of three dots in a box to the right)
Time (min.): 68
> 59:16 (with a pause symbol '||' to the right)
STOP GRAB RESTART

While paused, you can:

- View the log (see Section 4.3.1)
- Collect a Grab Sample (see Section 4.4)
- Stop the program — Press the STOP or F1 button to STOP the program.
- Resume the program — Press the F3 RESUME button to resume the program.
- When in the RUN mode the program can be stopped by pushing the F1 STOP.

While paused, the sampler skips sample events that would have occurred otherwise.

4.3 Post Sampling Activities

Post-sampling activities include:

- Viewing the Log (Section 4.3.1)
- Retrieving the Refrigerator Temperature Log (refer to the Installation and operation guide)
- Removing the sample bottles (Section 4.3.3)

4.3.1 View the Log

The sampler records events during the running program and summarizes them in a log. This log is held in the sampler memory under ARC:LOG:1. The current log file that is running would be LOG #1, once the sampler is stopped or program done the current log file goes to LOG #2. The sampler will record and display multiple log files.

To view the log after the completion of a program, or in the run mode press the **#5** button. To view different log files scroll using the up and down arrows to access different file numbers.

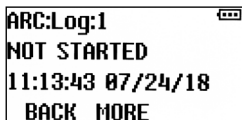

ARC:Log:1
NOT STARTED
11:13:43 07/24/18
BACK MORE

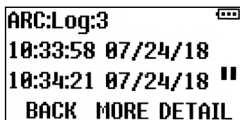

ARC:Log:3
10:33:58 07/24/18
10:34:21 07/24/18
BACK MORE DETAIL

You can also view the log while a program is paused.

While viewing the log, you can:

- Step forward through the LOG screens by pressing the up or down buttons.
- Pressing the MORE and DETAIL buttons will access the sampling data.
- Exit the log by pressing the BACK button.

The log generally contains the following information:

1. The number of samples collected (rc appears only if some samples required recycling)—this example indicates the sampling run that commenced at 11:01 AM on July 24 collected 2 samples].

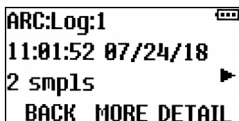

ARC:Log:1 ☰
11:01:52 07/24/18
2 smpls ▶
BACK MORE DETAIL

2. If recycle was activated, the log reports the number recycles and the alarm output is activated.

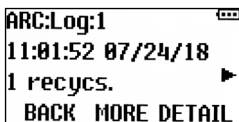

ARC:Log:1 ☰
11:01:52 07/24/18
1 recycs. ▶
BACK MORE DETAIL

3. That archived data can be reviewed from the user interface panel by pressing the 5 key when the selected program is running

(or waiting to be started), but not while the ADMINISTRATION or PROGRAM menu is active. The first line of the resulting display will indicate you are viewing log file 1, in which data for the current (or pending) sampling run is being (or will be) recorded.

```
ARC:Log:1
11:01:52 07/24/18
11:09:31 07/24/18
BACK MORE DETAIL
```

4. Bottle type, number and size of the containers to which those samples were discharged.

```
ARC:Log:7
Composite
1 5 gal.
BACK MORE DETAIL
```

5. If a log file's fourth screen indicates one or more exceptions were encountered, pressing its DETAIL [F3] key will display the timestamp and type of the first such exception detected during that program run. For example:

```
ARC:Log:1
11:01:52 07/24/18
2 excepts
BACK MORE DETAIL
```

```
ARC:Exc:1
11:07:25 07/24/18
power down
BACK
```

If power was lost during the program, the log reports the time of the power failure event and the time the power was restored.

6. Pressing the **DETAIL [F3]** key while viewing any sample container's screen will display the timestamp, as well as, the time needed to collect the first sample that was discharged to that container. You could then display the same information for each of the other samples in that container by pressing the up and/or down keys.

ARC:B1:S1 ☰ 11:19:52 08/16/18 15 sec 2.0 °C ▶ BACK	ARC:B1:S1 ☰ 09:39:57 09/07/18 25 sec rc 2.9 °C BACK
---	---

The refrigerated cabinet temperature is logged with each sample.

7. The log reports the average refrigerator temperature and the minimum and maximum recorded temperatures.

ARC:Log:1 ☰ T avg min max °C 2.8 2.8 2.9 ▶ BACK MORE DETAIL
--

4.3.2 User Interface Icon

Table 4-1 User Interface Panel Icons











Message	Description
	<p>Program is running.</p>
	<p>Program is paused.</p>
	<p>Time Start: program will automatically start at a specified time.</p>
	<p>Time Stop: program will automatically stop at a specified time.</p>
	<p>Sequence table is rotating.</p>
	<p>Recycle is activate/sampling cycle is being repeated.</p>

Table 4-1 User Interface Panel Icons

Message	Description
	Alarm Fault
	Temperature Alarm
	Arrow up / contact closed (Float circuit closed)
	Arrow down / contact open (Float circuit open)
	Power supply voltage

4.3.3 Sample Bottle Removal

After the program is complete, the bottles can be removed and prepared for the laboratory.

1. Gain access to the bottles by releasing the door latch and swinging the door open.
2. The bottles can then be removed from the rack by sliding the sequential table forward until it stops. (Platinum only.)
3. Lift the bottle rack and remove it from the sampler. *Rotate the discharge tube out of the way if needed.

***Jog Feature:** When the program is in the DONE or STOP mode the sequential table has a jog feature that allows the table to rotate 90°. This feature will allow easy access to the sample bottles when loading or unloading the bottles.

To activate the jog feature:

1. Push the 0 button and the table will jog 90°.
2. When the bottles have been installed, slide the table back in the refrigerator. Align the discharge tube (if adjustable) to the center of bottle 1 after the indexing table has located bottle 1.
3. Removed bottles should be capped and labeled according to the protocol established by your laboratory.

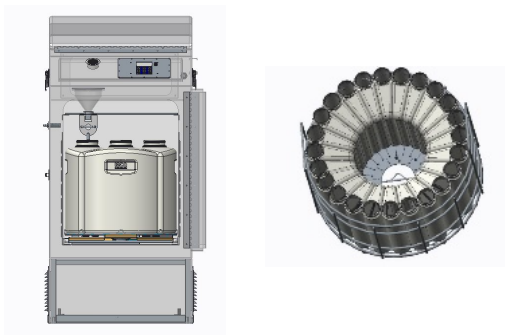

Figure 4-1 Removing the 24-bottle rack

4.4 Grab Samples

Grab samples let you take a single sample on demand and collecting it in an external container. You can collect a grab sample while the sampler is in RUN mode. A grab sample (volume test sample) can be taken at any time while the program is running.

Note

When grab samples are taken while a program is running, the samples are not logged or counted as part of the number of samples in the program.

To collect a Grab Sample:

1. When the program is running, push PAUSE (F3). Then push GRAB (F2) to enter grab sampling mode.

2. The screen will display **GRAB #1** and is ready to take a grab sample.
3. When grab sampling is complete, push the **F1 STOP** and then **F3 CONTINUE**. The program will take you back to the pause screen and push **F3 RESUME**. The program will return to the **RUN** screen.

4.5 Velocity Control Valve

The velocity control valve adjustment is to control the inlet velocity of the sample. The valve is located inside the refrigerator on the upper right side of the sample chamber and can be adjusted by rotating the knob.



*Figure 4-2
Velocity control
valve*

- If the lift height is between 1 and 3 meters, close the valve all the way (rotate clockwise), then open two complete rotations (rotate counterclockwise). The sampler is always shipped at this setting.
- Open the valve all the way if the lift height is 1 meter or less.
- Close the valve all the way if the lift height is greater than 3 meters.

Platinum/Optima CVE Refrigerated Sampler

Section 5 Maintenance

This section describes how to maintain your sampler. If you think your sampler requires repair, or if you have questions concerning its operation or maintenance, contact your authorized Teledyne ISCO service facility or Technical Service Department:

Phone: (800) 228-4373

(402) 464-0231 (international)

FAX: (402) 465-3001

E-mail: iscoeps@teledyne.com

5.1 Periodic Maintenance Checklist

Perform maintenance as needed.

- Clean or replace the wetted parts (bottles, suction line, strainer, sample chamber, discharge tube).
- Clean the sampler when needed.
- Keep the refrigeration air vents clean.

5.2 Fuse

The control system operates on 12 VAC power supplied by a transformer located in the vacuum pump compartment. Those components are protected by a fast-acting, 10A/250 V cartridge fuse. The enclosed fuse holder is mounted next to the transformer.

- That fuse can be checked and/or replaced by pulling the front cover of the holder forward which automatically ejects the right end of the fuse.
- The control system can be powered down by tipping the top of the holder up and to the left.

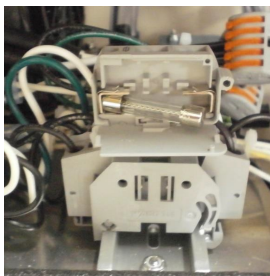

Figure 5-1 Fuse in the holder

5.3 Cleaning the Sample Chamber

To clean the sample chamber:

1. Stop or Pause the program.
2. Remove the chamber from the sampler.
3. Remove the 10 screws that hold the lid and chamber body together.
Place the chamber parts into warm soapy water and clean the chamber and liquid-sensor electrodes using a brush or sponge.
4. Assemble the chamber using the screws. Be sure that the seal is properly seated and the screws are tight. Loose screws or improperly placed seal can cause a vacuum leak.
5. Install the sample chamber back into the unit.

5.3.1 Sample Chamber Removal

To remove the sample chamber:

1. Unscrew the white hose fittings on top of the sample chamber and loosen the compression nut. Slide the stainless steel intake tube in.
2. Use the lever to loosen the set collar.
3. Lift the sample chamber out of the collar.
4. Remove the stainless steel intake tube from the chamber and the two wires from the liquid-sensor electrodes.

5. The discharge hose will come out along with the sample chamber.

5.3.2 Sample Chamber Installation

Upon installation of the chamber, it is important that the fittings are oriented in the directions as shown in Figure 5-2.



*Figure 5-2 Sample Chamber Inlets
(Graduation marks on this side)*

☑ Note

Make sure the chamber is properly oriented with the graduation (volumetric) marks facing the sampler door opening. It is important that the sample chamber is installed correctly.

5.3.3 Installing the Tubing

1. Install the tubing (WW050) onto the chamber discharge fitting and secure it with a cable tie.



Figure 5-3 Location of the chamber discharge fitting

2. Connect the two wires to the liquid-sensor electrodes and slide the intake tube into the center fitting with the compression nut.



Figure 5-4 Center fitting with the compression nut

3. Connect the hose fitting to the white elbow. fit the sample chamber into the set collar. Then, orient the graduation marks on the sample chamber body toward the front of

the sampler. Tighten the set collar by pushing the gold lever in.



Figure 5-5 Connecting the vacuum / pressure line

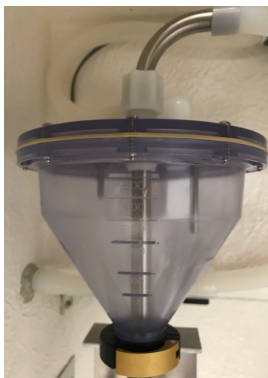

Figure 5-6 Connecting the vacuum / pressure tubing

4. Slide the silicone tubing over the stainless steel intake tube. The tubing connection to the sample chamber should have no kink, just a gradual bend. The installed sample

chamber should have the graduation marks facing forward. To adjust the sample volume loosen the compression nut and slide the intake tube in for a smaller sample and out for a larger sample. Tighten the compression nut before taking a sample.



Figure 5-7 Sample chamber with tubing

5.3.4 Sample Chamber Parts

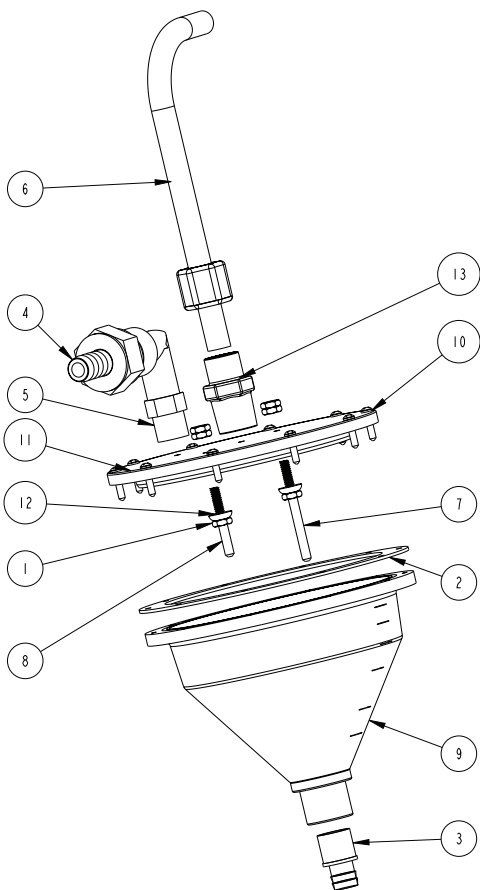

	Part	Number	Additional Information
1	Nut, Hex 10-24	232116000	3 per electrode
2	Gasket	WW425	
3	Chamber Base Fitting	WW429	
4	1/2 Hose X Swivel Fitting	WW434	
5	1/2 MNPT x MGHT Elbow	WW435	
6	Intake Tube	WW453	
7	CVE-16 Electrode long	WW454	
8	CVE-16 Electrode short	WW455	
9	500mL Sample Chamber Base	WW458	
10	6-32 x 5/8 Pan head Screw	WW466	
11	CVE-16 Sampler Chamber Lid	WW526	
12	Conical washer w/gasket	WW527	
13	Fitting, 1/2" OD Tube X 1/2" MNPT	WW612	

5.4 Compressor/Vacuum Pump

Each sampling system is equipped with one continuous-duty, permanently lubricated, piston or diaphragm compressor/vacuum pumps that provide long-term consistent sampling with vertical lifts of up to 28 feet (US 23 ft. lift standard). ***These pumps need no routine maintenance.***

The pump and its 4-way solenoid valve are mounted on a metal plate behind the sampler's upper rear access panel. If your pump's performance declines unacceptably, replacement pumps and service/rebuild kits (including instructions) can be obtained from Teledyne ISCO.

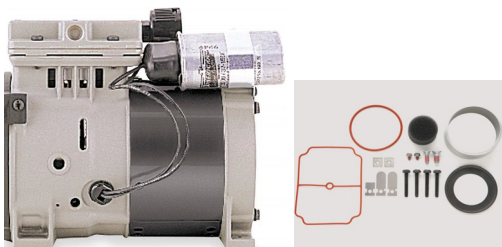

Figure 5-8 Pump and parts

5.5 Clean or Replace Wetted Parts

For general cleaning, you can wash the strainer and sample bottles with a brush and warm soapy water and then rinse with clean water. You can clean the liquid path through the wetted parts by placing the strainer in a cleaning solution and pumping it through the delivery system. Next, place the strainer in clean water and pump it through the delivery system to rinse it. If these items are severely contaminated, replace them.

5.5.1 Sampler Cleaning Guidelines

Keeping the sampler clean and protected from harsh elements may extend the usable life of the sampler. When necessary, clean the exterior and interior of the sampler and sample chamber with warm soapy water and brush, then rinse with water. Be sure to use a detergent that is compatible with low-density polyethylene, polystyrene, PVC, ABS, polycarbonate and NORYL^{TM1}. Avoid using strong solvents and acids.

1. NORYL is a registered trademark of SABIC Innovative Plastics IP B.V.

Table 1: Wetted Parts

A	Strainer (316 stainless steel, polypropylene, or CPVC)
B	Suction Line (vinyl)
C	Tubing Connector (316 stainless steel elbow or plastic)
D	Discharge Tube (silicone)
E	Bottle (glass, polypropylene, or polyethylene)

Note

For application-specific requirements, consult with your laboratory to establish cleaning or replacement protocols.

Information included herein is controlled by the Export Administration Regulations (EAR) and requires an export license, license exception or other approval from the appropriate U.S. Government agency before being exported from the United States or provided to any foreign person. Diversion contrary to U.S. law is prohibited.



Teledyne ISCO, Inc.

P.O. Box 82531, Lincoln, Nebraska, 68501 USA

Toll-free: (800) 228-4373 • Phone: (402) 464-0231 • Fax: (402) 465-3091

teledyneisco.com



Teledyne ISCO is continually improving its products and reserves the right to change product specifications, replacement parts, schematics, and instructions without notice.