

Overview



MAG 8000 is a comprehensive meter which intelligent information and high performance measurement as well as the easy to install concept take cost of ownership and customer service to a new level for water meter.

Benefits

Easy to install

- Compact or remote solution with factory mounted cable and customer setting from factory
- IP68/NEMA 6P enclosure. Sensor can be buried.
- Flexible power supply - internal or external battery pack or mains power supply with battery back-up possibilities
- Superior measurement
- Down to 0.2 % maximum uncertainty
- OIML R 49 type approval
- FM Fire Service Approval
- Bi-directional measurement

Long lasting performance/Low cost of Ownership

- No moving parts means less wear and tear.
- Up to 6 to 10 years maintenance-free operation in typical revenue application
- Robust construction built for the application

Intelligent information, easy to access

- Embedded self-testing and alarm/fault detection feature
- Internal data logger
- Advanced statistics and diagnostics
- Various Add-on communication modules

Application

The following MAG 8000 versions are available as stand-alone water meters:

- MAG 8000 (7ME6810) for abstraction and distribution network
- MAG 8000 CT (7ME6820) for revenue and bulk metering

Design

MAG 8000 is designed to minimize power consumption.

The product program consists of

- Basic and advanced version
- Sensor sizes from DN 25 to 1200 (1" to 48")
- Compact and remote installation in IP68/NEMA 6P enclosure and factory-mounted cable
- SIMATIC PDM and Flow Tool PC configuration softwares

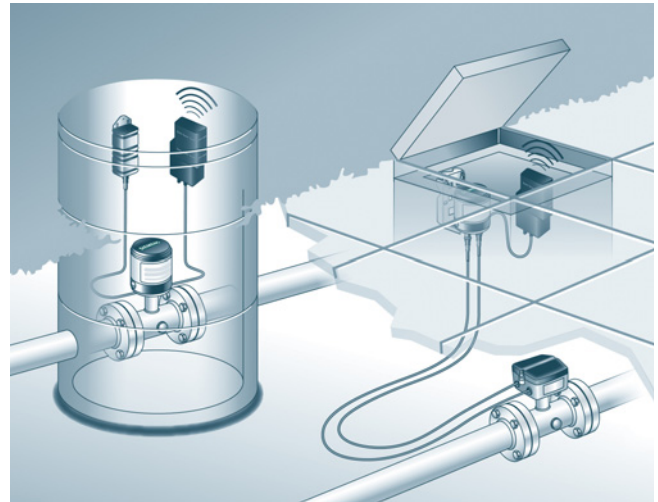

Modbus/Encoder module

Flow Measurement

SITRANS FM

Battery-operated water meter MAG 8000

Function

MAG 8000 is a microprocessor-based water meter with graphical display and key for optimum customer operation and information on site. The transmitter drives the magnetic field in the sensor, evaluates the flow signal from the sensor and calculates the volume passing through. It delivers the required information via the integrated pulse output or communication interfaces as part of a system solution. Its intelligent functionality, information and diagnostic ensure optimum meter performance and information to optimize water supply and billing.



MAG 8000 can be ordered as a Basic or an Advanced version.

Features/Version	MAG 8000 Basic	MAG 8000 Advanced
Measuring frequency in battery power mode (Manually selected) ¹⁾	1/15 or 1/30 or 1/60 Hz	from 6.25 to 1/60 Hz depending of sensor size
Output MAG 8000	2 FW/RV/AI/CA	2 FW/RV/AI/CA
Communication	Add-on	Add-on
Data logger	Yes	Yes
Insulation test	Yes	Yes
Leakage detection	No	Yes
Meter utilization	No	Yes
Statistics	No	Yes
Tariff	No	Yes
Settle date (Revenue)	No	Yes

¹⁾ Excitation frequency settings with mains power supply, see technical specifications for each version:

Some information is accessible via the display whereas all information is accessible via the IrDA communication interface with the PDM software. Data and parameters are registered in a EEPROM. They can all be read, but changing the information demands a software password or a hardware key attached to the printed circuit board.

The SIMATIC PDM tool gives the possibility of testing and verifying the flowmeter on site and creating a printed "Qualification Certificate" with all specific data that define the quality status of the measurement.

The Qualification Certificate consists of two pages with information about the actual status of the sensor:

Part 1 provides general settings, sensor and battery info, totalizer values and pulse output settings.

Part 2 provides detailed information about electronic and sensor functionality and a main parameter list for evaluating the functionality of the MAG 8000 water meter.



SIMATIC PDM

Details about the SIMATIC PDM tool can be found in chapter "Communication and Software" in catalogue FI01.

Technical specifications

Transmitter	
Installation	Compact (integral) Remote with factory-mounted cable 5, 10, 20 or 30 m (16.4, 32.8, 65.6 or 98.4 ft)
Enclosure	Stainless steel top housing (AISI 316) and coated brass bottom. Remote wall mount bracket in stainless steel (AISI 304).
Cable entries	2 × M20 (one gland for one cable of size 6 ... 8 mm (0.02 ... 0.026 ft) is included in the standard delivery)
Display	Display with 8 digits for main information Index, menu and status symbols for dedicated information
Resolution	Totalized information can be displayed with 1, 2 or 3 decimals or automatic adjustment (default)
Flow unit	
Europe	Volume in m ³ and flow rate in m ³ /h
US	Volume in Gallon and flow rate in GPM
Australia	Volume in Mi and flow rate as MI/d
Optional display units	Volume: m ³ × 100, l × 100, G × 100, G × 1000, MG, CF × 100, CF × 1000, AF, Al, kl, BBL42 Flow: m ³ /min, m ³ /d, l/s, l/min, GPS, GPH, GPD, MGD, CFS, CFM, CFH, BBL42/s, BBL42/min, BBL42/h, BBL42/d
Digital output	2 passive outputs (MOS), individual galvanically isolated Maximum load ± 35 V DC, 50 mA short circuit protected
Output A function	Programmable as pulse volume – forward – reverse – forward/net – reverse/net
Output B function	Programmable as pulse volume (like output A), alarm
Output	Max. pulse rate of 50 Hz (pulse B) and 100 Hz (pulse A), pulse width of 5, 10, 50, 100, 500 ms

Transmitter	
Communication	IrDA: Standard integrated infrared communication interface with Modbus RTU protocol
Add-on modules	<ul style="list-style-type: none"> RS 232 serial interface with Modbus RTU (Rx/Tx/GND), point to point with max. 15 m cable RS 485 serial interface with Modbus RTU (+/-/GND), multidrop with up to 32 devices with max. 1000 m cable Encoder interface module (for Itron 200WP) "Sensus protocol" 3G/UMTS module with or without analog input cable
Power supply	Auto detection of power source with display symbol for operation power
Internal battery pack	1 D-Cell 3.6 V/16.5 Ah 2 D-Cell 3.6 V/33 Ah
External battery pack	4 D-Cell 3.6 V/66 Ah
Mains power supply	12 ... 24 V AC/DC (10 ... 32 V) 2 VA 115 ... 230 V AC (85 ... 264 V) 2 VA Both mains power supply systems are upgradable for battery backup via internal D-Cell (3.6 V 16.5 Ah) or external battery pack.
Cable	3 m (9.8 ft) for external connection to mains supply (without cable plug)

Flow Measurement

SITRANS FM

Battery-operated water meter MAG 8000

Technical specifications (continued)

Features	
Application identification	Tag number up to 15 characters
Time and date	Device embedded Real Time Clock (Synchronization with NTP server if 3G/UMTS module connected)
Totalizer	
MAG 8000	Totalizer 1 and Totalizer 2: Configurable to Forward, Reverse and Bidirectional netflow Totalizer 3: (following totalizer 1 setting) resettable via display key
Measurement	
Low flow cut-off	
• 7ME6810	Cut-off at 15 mm/s
• 7ME6820	Cut-off at 15 mm/s
Empty pipe detection	Symbolised in display
Data logger	Logging of 26 records: selectable as daily, weekly or monthly logging
Alarm	Active alarm is indicated on the display.
Data protection	All data stored in an EEPROM. Totalizers 1 and 2 are backed up every 10 min, statistic every hour and power consumption and temperature measurement every 4 hours. Password protection of all parameters and hardware protection of calibration and revenue parameters.
Battery power management	Optimal battery information on remaining capacity. Calculated capacity includes all consuming elements and available battery capacity is adjusted related to change in ambient temperature. Numbers of power-ups Date and time registered for first and last time power alarm.
Diagnostic	
Continuous self test including	Coil current to drive the magnetic field Signal input circuit Data calculation, handling and storing
Alarm statistics and logging for fault analyzing	Electrode impedance to check actual media contact Flow simulation to check pulse and communication signal chain for correct scaling Number of sensor measurements (excitations) Transmitter temperature (battery capacity calculation) Low impedance alarm for change in media Flow alarm when defined high flow exceeds Verification mode for fast measure performance check
Insulation test	Test of signal immunity against disturbance and bad installation. Test interval is selectable and measurement is interrupted during the test period of 4 min.

Features	
Leakage detection (only Advanced version)	Monitoring the lowest flow or volume during selected time window within 24 hours. Leakage is detected over a selectable period where monitored value exceed the possible leakage level. Min. and max. values are stored with date registration. Last store value visible on the display.
Meter Utilization (only Advanced version)	6 registers for monitoring total time the meter has operated in different flow intervals. Registered intervals are free selectable as % of Q _n (Q3).
Tariff (only Advanced version)	6 tariff registers count the volume delivered within the selected tariff windows, based on time of day or flow rates or a combination. Tariff can also be used for consumption profile where consumption is related to different time intervals or flow rates. Tariff values visible on the display.
Settling date (only Advanced version)	On a predefined date the totalizer 1 index value is stored. Old values are stored to show the latest two totalized 1 index values. Settling values visible on the display.
Statistic (only Advanced version)	Min. flow rate with time and date registration Max. flow rate with time and date registration Min. daily consumption with date registration Max. daily consumption with date registration Latest 7 days total and daily consumption Actual month consumption Latest month consumption
PC Configuration Software PDM	<ul style="list-style-type: none"> • Meter configuration – online and offline mode • Own parameter settings • Parameter documentation • Print and export of data and parameters PDM 9.0/9.1 Service Pack 1

Technical specifications (continued)**MAG 8000 water meter uncertainty**

To ensure continuous accurate measurement, flowmeters must be calibrated. The calibration is conducted at Siemens flow facilities with traceable instruments referring directly to the physical unit of measurement according to the International System of Units (SI).

Therefore, the calibration certificate ensures recognition of the test results worldwide, including the US (NIST traceability).

Siemens offers accredited calibrations assured to ISO 17025 in the flow range from 0.0001 m³/h to 10 000 m³/h. Siemens Flow Instruments accredited laboratories are recognized by ILAC MRA (International Laboratory Accreditation Corporation - Mutual Recognition Arrangement) ensuring international traceability and recognition of the test results worldwide.

The selected calibration determines the accuracy of the meter. A standard calibration results in max. $\pm 0.4\%$ uncertainty and an extended calibration $\pm 0.2\%$. A calibration certificate follows every sensor and calibration data are stored in the meter unit.

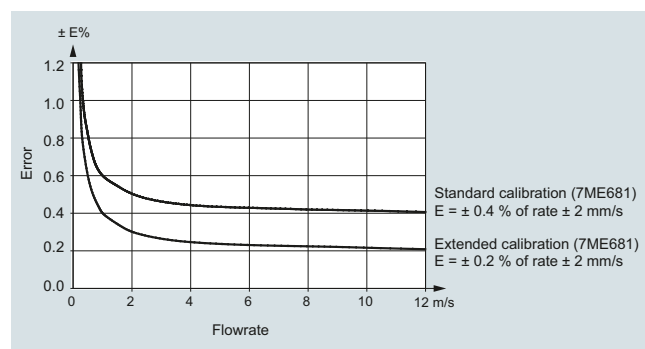
**MAG 8000 (7ME6810) for Fire Service applications**

MAG 8000 (7ME6810) is FM Fire Service approved for automatic fire protection systems according to the Fire Service Meters Standard, Class Number 1044. The approval is applicable for the sizes DN 50, DN 80, DN 100, DN 150, DN 200, DN 250, and DN 300 (2", 3", 4", 6", 8", 10", and 12") with ANSI B16.5 Class 150 flanges. The FM Fire Service approved product can be ordered via the Z-options P20, P21 and P22.

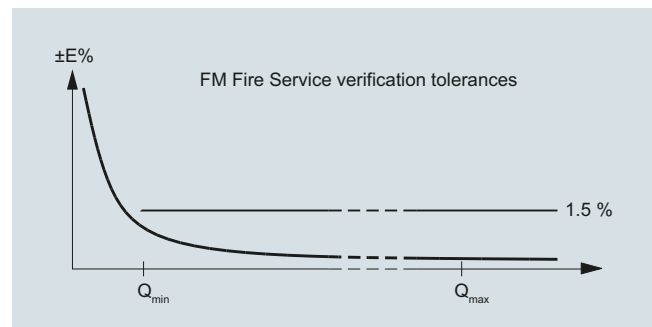
**Grounding**

The sensor body must be grounded using grounding straps and/or grounding rings to protect the flow signal against stray electrical noise. This ensures that the noise is carried through the sensor body and a noise-free measuring area within the sensor body. For MAG 8000 Irrigation grounding rings on both sides are factory-mounted.

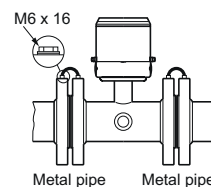
**Metal pipes**

On metal pipes, connect the straps to both flanges.

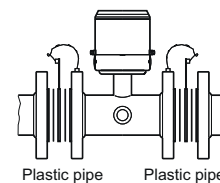
**Plastic pipes**

On plastic pipes and lined metal pipes, optional grounding rings must be used at both ends.

Grounding rings has to be ordered separately see "grounding ring kit"

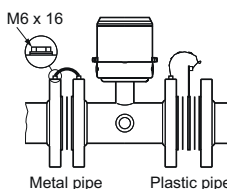
**Combination of metal and plastic pipes**

A combination of metal and plastic requires straps for metal pipe and grounding rings for plastic pipe.

Flow Measurement

SITRANS FM

Battery-operated water meter MAG 8000

Technical specifications (continued)

Battery operation time and calculation

The battery operation time depends on the connected battery pack as well as the operation condition of the meter.

MAG 8000 calculates the remaining capacity every 4 hours and includes all consuming elements. Calculation compensates for temperature influence on battery capacity.

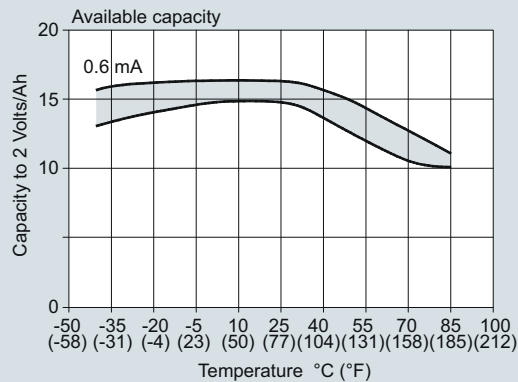

The graphic shows the effect from other temperatures. A variation in temperature from 15 °C to 55 °C (59 to 131 °F) reduces the capacity by 17 % in the table from 15 Ah to 12.5 Ah.

At typical revenue scenario of expected battery operation time can be seen in the table below.

The measurement for calculating the rest capacity of the battery life time is only completed if the system has no active fatal faults or the empty pipe is active. Maximum battery specification is 10 years operation.

Scenario - Revenue application

Output A	Pulse rate max. 10 Hz
Output B	Alarm or call-up
Meter dialog	1 hour per month
Add-com	None
Temperature profile	<ul style="list-style-type: none"> • 5 % at 0 °C (32 °F) • 80 % at 15 °C (59 °F) • 15 % at 50 °C (122 °F)

Battery lifetime (subject to the assumptions mentioned above)

MAG 8000 for abstraction and distribution network applications (7ME6810) and MAG 8000 CT for revenue and bulk metering (7ME6820)

Excitation frequency (24 h operation)	1/60 Hz	1/30 Hz	1/15 Hz	1/5 Hz	1.5625 Hz	3.125 Hz	6.25 Hz
2 D-Cell battery 33 Ah Internal battery pack	DN 25 ... 150 (1" ... 6")	9 years	9 years	7 years	43 months	8 months	3 months
	DN 200 ... 600 (8" ... 24")	9 years	6 years	4 years	22 months	3 months	1 month
	DN 700 ... 1200 (28" ... 48")	7 years	4 years	2 years	12 months	1 months	N/A
4 D-Cell battery 66 Ah External battery pack	DN 25 ... 150 (1" ... 68")	15 years	15 years	14 years	86 months	16 months	7 months
	DN 200 ... 600 (8" ... 24")	15 years	13 years	8 years	44 months	7 months	3 months
	DN 700 ... 1200 (28" ... 48")	14 years	9 years	5 years	24 months	3 months	N/A

Typical battery lifetime scenario for MAG 8000 with 3G module

Transmission once a day and MAG 8000 factory settings

2 D-Cell battery 33 Ah Internal battery pack	3 ... 4 years
4 D-Cell battery 66 Ah External battery pack	7 ... 8 years

External battery pack can be used as battery backup for mains power supply (if two cable entries in one cable gland are needed, order cable glands with two entries, see accessories on page 3/xx)

Serial RS 232/RS 485 add-on communication modules are designed for mains powered systems as the battery operation time will be reduced. At 1 hour communication per month (all meter data collected 2 times per day) and the module is connected, the operation time is reduced to:

- RS 232:
 - Switched on constantly:
 - 6.4 months for 2 D-cell internal battery pack / 12.8 months for 4 D-cell ext. battery pack
 - Switched on 2 s/day:
 - 39 months for 2 D-cell internal battery pack / 78 months for 4 D-cell ext. battery pack
- RS 485:
 - With the termination resistor on:
 - 2.3 months for 2 D-cell internal battery pack / 4.6 months for 4 D-cell ext. battery pack
 - With the termination resistor off:
 - 39 months for 2 D-cell internal battery pack / 78 months for 4 D-cell ext. battery pack, in case the entire communication time is less than 4 hours/day

Dimensional drawings

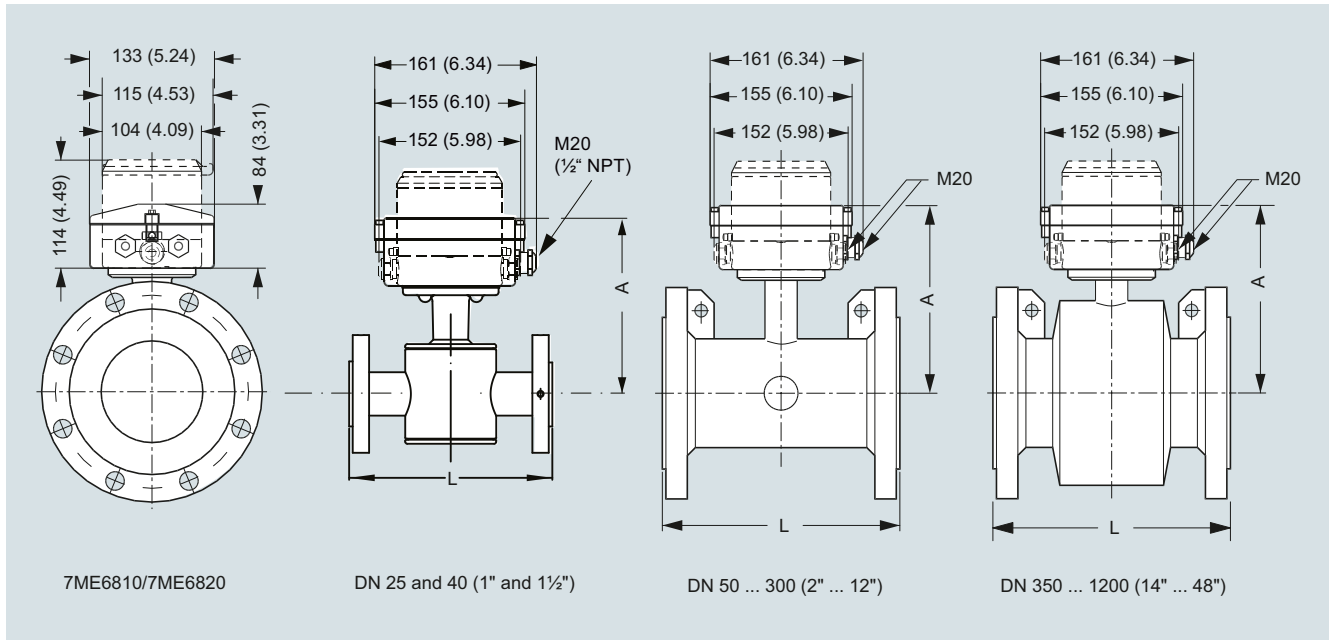

Dimensions in mm (inch)

Nominal DN size	A	L, lengths ¹⁾							Weight ²⁾	
		EN 1092-1 PN 10	EN 1092-1 PN 16/ PN 16 non-PED	EN 1092-1 PN 40	ANSI 16.5 Class 150	AS 4087 PN 16	AWA C-207 Class D	AS 2129	kg	lb
mm (inch)	mm (inch)	mm	mm	mm	inch	mm	mm	mm		
25 (1)	188 (7.4)	-	-	200	7.9	200	-	200	6	13
40 (1½)	203 (8.0)	-	-	200	7.9	200	-	200	9	20
50 (2)	178 (7.0)	-	200	-	7.9	200	-	-	11	25
65 (2½)	181 (7.1)	-	200	-	7.9	200	-	-	13	29
80 (3)	191 (7.5)	-	200	-	7.9	200	-	-	15	34
100 (4)	197 (7.8)	-	250	-	9.8	250	-	-	17	38
125 (5)	210 (8.3)	-	250	-	9.8	250	-	250	22	50
150 (6)	224 (8.8)	-	300	-	11.8	300	-	-	28	63
200 (8)	249 (9.8)	350	350	-	13.8	350	-	-	50	113
250 (10)	276 (10.9)	450	450	-	17.7	450	-	-	71	160
300 (12)	303 (11.9)	500	500	-	19.7	500	-	-	88	198
350 (14)	365 (14.4)	550	550	-	21.7	550	-	-	127	279
400 (16)	391 (15.4)	600	600	-	23.6	600	-	-	145	318
450 (18)	421 (16.6)	600	600	-	23.6	600	-	-	175	384
500 (20)	447 (17.6)	600	600	-	23.6	600	-	-	225	494
600 (24)	497 (19.6)	600	600	-	23.6	600	-	-	340	747
700 (28)	548 (21.6)	700	875/700	-	N/A	700	700	-	316	694
750 (30)	573 (22.6)	N/A	N/A	-	N/A	N/A	750	-	N/A	N/A
800 (32)	603 (23.7)	800	1000/800	-	N/A	800	800	-	398	1045
900 (36)	656 (25.8)	900	1125/900	-	N/A	900	900	-	476	1045
1000 (40)	708 (27.9)	1000	1250/1000	-	N/A	1000	1000	-	602	1322
1050 (42)	708 (27.9)	N/A	N/A	-	N/A	N/A	1050	-	N/A	N/A
1100 (44)	759 (29.9)	N/A	N/A	-	N/A	N/A	1100	-	N/A	N/A
1200 (48)	814 (32.0)	1200	1500/1200	-	N/A	1200	1200	-	887	1996

¹⁾ Tolerances on built-in length: DN 15 to DN 200 (½" to 8"): +0/-3 mm (+0/-0.12"), DN 250 to DN 400 (10" to 16"): +0/-5 mm (+0/-0.20"), DN 450 to DN 600 (18" to 24"): +5/-5 mm (+0.20/-0.20"), DN 700 to DN 1200 (28" to 48"): +10/-10 mm (+0.39/-0.39").

²⁾ For remote version the sensor weight is reduced with 2 kg (4.5 lbs).

Flow Measurement

SITRANS FM

Battery-operated water meter MAG 8000

Dimensional drawings (continued)

Remote version

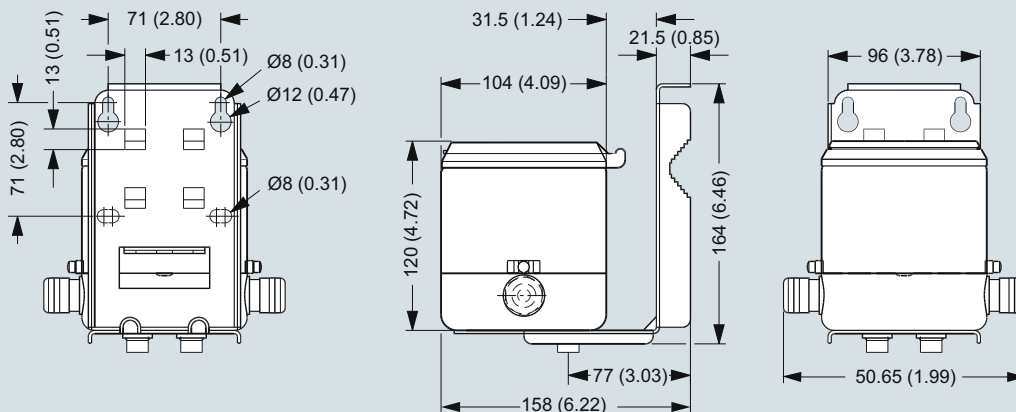

Dimensions in mm (inch), weight 3.5 kg (8 lbs)

External battery pack

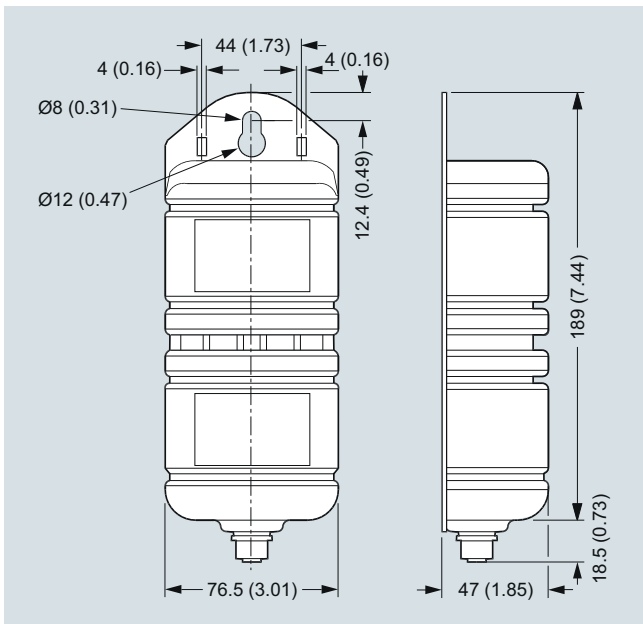

Dimensions in mm (inch), weight 2.0 kg (4.5 lbs)

Battery pack has to be mounted in upwards position to ensure maximum battery capacity.

Grounding rings

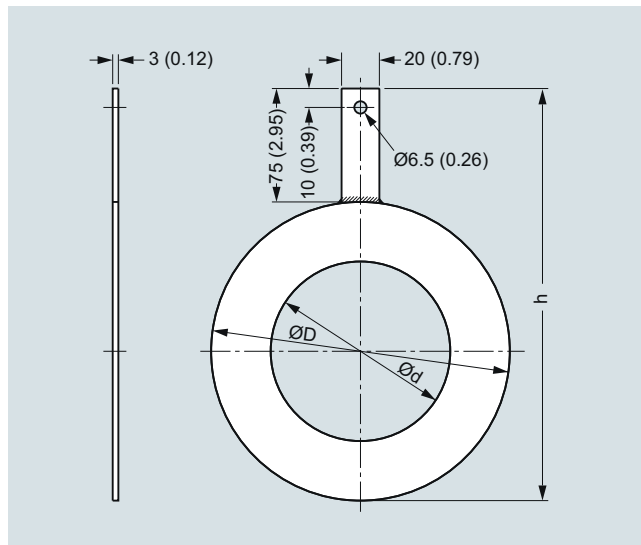

Dimensions in mm (inch) for grounding rings MAG 8000 with EPDM lining (7ME6810 and 7ME6820) DN 25 to DN 300

Dimension	Internal diameter (d)	Outside diameter (D)	h
DN 25	27	68	143
DN 40	38	88	163
DN 50	52	100	175
DN 65	64	120	195
DN 80	79	133	208
DN 100	95	158	233
DN 125	115	188	263
DN 150	145	216	291
DN 200	193	268	343
DN 250	246	324	399
DN 300	295	374	449

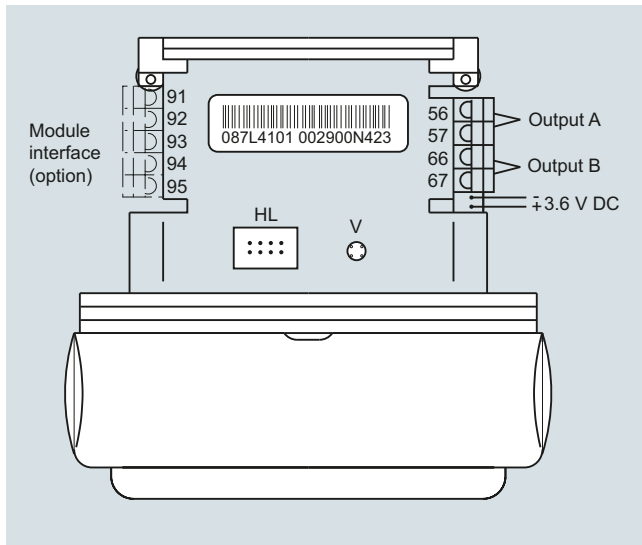
Circuit diagramsElectrical installation and pulse output – Connection diagram

HL = Hardware lock key connection
V = Push button for verification mode

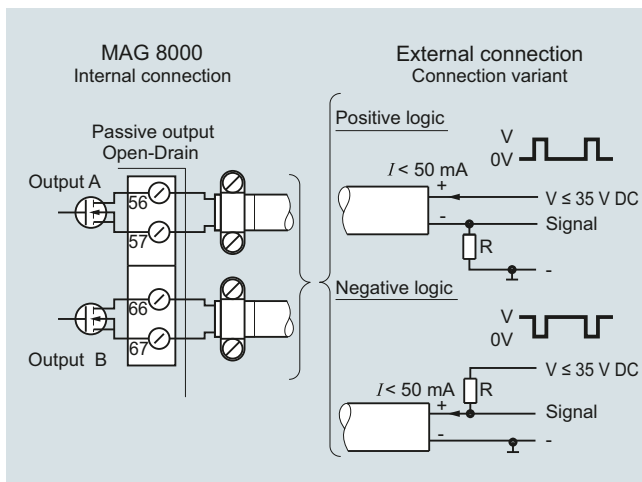
Pulse wire connection

The pulse output can be configured as volume, alarm or call-up.
The output can be connected as positive or negative logic.
R = pull up/down is selected in relation to the Vx power supply
and with a max. current I of 50 mA.

Use shielded cable to avoid EMC problems. Make sure the
shield is correctly mounted under the cable clamp (no pig tail).

Flow Measurement

SITRANS FM

MAG 8000 for abstraction and distribution network application (7ME6810)

Overview



Benefits

Easy to install

- Compact or remote solution with factory mounted cable
- IP68/NEMA 6P enclosure. Sensor can be buried.
- Flexible power supply - internal or external battery pack or mains power supply with battery back-up possibilities

Long-term stability/Low cost of ownership

- No moving parts in a robust construction means less wear and tear
- Basic and advanced transmitter versions with different optional add-on communication modules fulfil various customer requirements for high cost efficiency
- Up to 0.2 % maximum uncertainty
- Bi-directional measurement with an outstanding low flow performance
- Up to 10 years maintenance-free operation in typical applications

Intelligent information, easy to access

- Advanced information on site
- Advanced statistics and diagnostics
- Optional high-performance 3G/UMTS module offers an efficient solution for remote measurement and monitor via wireless networks.

Technical specifications

Meter	
Accuracy	Standard calibration: ± 0.4% ± 2 mm/s Extended calibration DN 50 ... DN 300 (2" ... 12"): ± 0.2 % of rate ± 2 mm/s
Low flow cut-off (default)	15 mm/s
Media conductivity	Clean water > 20 µs/cm
Temperature	
Ambient	-20 ... +60 °C (-4 ... +140 °F)
Media	0 ... 70 °C (32 ... 158 °F)
Storage	-40 ... +70 °C (-40 ... +158 °F)
Enclosure rating	
Remote sensor	IP68 to EN 60529/NEMA 6P, 10 mH ₂ O cont.
Compact version	IP68 to EN 60529/NEMA 6P, 3 mH ₂ O for six months
Certificates and approvals	
Calibration	
• Standard calibration	2 x 25 % and 2 x 90 % (default)
• Special calibration	5-point calibration: 20 %, 40 %, 60 %, 80 %, 100 % of factory Q _{max} 10-point calibration: ascending and descending at 20 %, 40 %, 60 %, 80 %, 100 % of factory Q _{max} Matched-pair calibration: default, 5-point, 10-point
Material certificate EN 10204-3.1	Available when ordering together with meter ¹⁾
Drinking water approvals	<ul style="list-style-type: none"> • NSF/ANSI Standard 61²⁾ (cold water) USA • WRAS (BS 6920 cold water) UK • ACS Listed France • DVGW W270 Germany • Belgaqua (B) • MCERTS (GB)
Fire Service Approvals	FM Fire Service Meter (Class Number 1044) ³⁾
Conformity	<ul style="list-style-type: none"> • PED: 2014/68/EU⁴⁾ • EMC: IEC/EN 61326
Sensor version	DN 25 ... 1200 (1" ... 48")
Sensor material	Carbon steel ASTM A 105, with corrosion resistant two-component epoxy coating (150 µm/300 µm) Corrosivity category C4M, according to ISO 12944
Measuring principle	Electromagnetic induction
Excitation frequency	
Basic version	
• Battery-powered	DN 25 ... 150 (1" ... 6"): 1/15 Hz DN 200 ... 600 (8" ... 24"): 1/30 Hz DN 700 ... 1200 (28" ... 48"): 1/60 Hz
• Mains-powered	DN 25 ... 150 (1" ... 6"): 6.25 Hz DN 200 ... 600 (8" ... 24"): 3.125 Hz DN 700 ... 1200 (28" ... 48"): 1.5625 Hz

Meter	
Advanced version	
• Battery-powered	DN 25 ... 150 (1" ... 6"): 1/15 Hz (adjustable up to 6.25 Hz; reduced battery lifetime) DN 200 ... 600 (8" ... 24"): 1/30 Hz (adjustable up to 3.125 Hz; reduced battery lifetime) DN 700 ... 1200 (28" ... 48"): 1/60 Hz (adjustable up to 1.5625 Hz; reduced battery lifetime)
• Mains-powered	DN 25 ... 150 (1" ... 6"): 6.25 Hz DN 200 ... 600 (8" ... 24"): 3.125 Hz DN 700 ... 1200 (28" ... 48"): 1.5625 Hz
Flanges	
EN 1092-1 (DIN 2501)	DN 25 and DN 40 (1" and 1½"): PN 40 (580 psi) DN 50 ... 150 (2" ... 6"): PN 16 (232 psi) DN 200 ... 1200 (8" ... 48"): PN 10 or PN 16 (145 psi or 232 psi) DN 350 ... DN 600 (14" ... 24"): PN25 or PN40 (362 psi or 580 psi)
ANSI 16.5 Class 150	1" ... 24": 20 bar (290 psi)
AWWA C-207	28" ... 48": PN 10 (145 psi)
AS 4087	DN 50 ... 1200 (2" ... 48"): PN 16 (232 psi)
Liner	EPDM
Electrode and grounding electrodes	Hastelloy C276/2.4819
Grounding straps	Grounding straps are premounted from the factory on each side of the sensor.

- ¹⁾ Has to be ordered with the meter. It is not possible to order the certificate afterwards.
- ²⁾ Including Annex G
- ³⁾ Not for sensors with 300 µm coating.
- ⁴⁾ For further information on PED standard and requirements see page 10/15

Flow Measurement

SITRANS FM

MAG 8000 for abstraction and distribution network application (7ME6810)

Selection and ordering data

Article No.

SITRANS F M MAG 8000 water meter

7ME6810-

➤ Click on the Article No. for the online configuration in the PIA Life Cycle Portal.

Diameter

DN 25 (1")
 DN 40 (1½")
 DN 50 (2")
 DN 65 (2½")
 DN 80 (3")
 DN 100 (4")
 DN 125 (5")
 DN 150 (6")
 DN 200 (8")
 DN 250 (10")
 DN 300 (12")
 DN 350 (14")
 DN 400 (16")
 DN 450 (18")
 DN 500 (20")
 DN 600 (24")
 DN 700 (28")¹⁾
 DN 750 (30")¹⁾
 DN 800 (32")¹⁾
 DN 900 (36")¹⁾
 DN 1000 (40")¹⁾
 DN 1050 (42")¹⁾
 DN 1100 (44")¹⁾
 DN 1200 (48")¹⁾

2 D
 2 R
 2 Y
 3 F
 3 M
 3 T
 4 B
 4 H
 4 P
 4 V
 5 D
 5 K
 5 R
 5 Y
 6 F
 6 P
 6 Y
 7 D
 7 H
 7 M
 7 R
 7 U
 7 V
 8 B

Flange norm and pressure rating

EN 1092-1

PN 10 (DN 200 ... 1200 (8" ... 48"))
 PN 16 (DN 50 ... 1200 (2" ... 48"))
 PN 16, non-PED (DN 700 ... 1200 (28" ... 48"))
 PN 25 (DN 350 ... 600 (12" ... 24"))
 PN 40 (DN 25 ... 50 (1" ... 1½"), DN 350 ... 600 (12" ... 24"))

B
 C
 D
 E
 F
 J
 L
 N

ANSI B16.5

Class 150
 AWWA C-207
 Class D (28" ... 48")

AS 4087

PN 16 (DN 50 ... 1200 (2" ... 48"))

Sensor version

EPDM liner and Hastelloy electrodes, corrosion-resistant coating of category C4
 EPDM liner and Hastelloy electrodes, 300 µm coating

3
 4

Calibration

Standard ± 0.4 % of rate ± 2 mm/s
 Extended ± 0.2 % of rate ± 2 mm/s DN 50 ... 300 (2" ... 12")
 NMI M 10 (2.5%) without verification

1
 2
 3

Article No.

SITRANS F M MAG 8000 water meter

7ME6810-

Region version

Europe (m3, m3/h, 50 Hz)
 USA (Gallon, GPM, 60 Hz)
 Australia (MI, MI/d, 50 Hz)

1
 2
 3

Transmitter type and installation

Basic version integral or sensor
 Basic version, remote cables mounted on sensor with IP68/NEMA 6P plugs:
 • 5 m (16.4 ft)
 • 10 m (32.8 ft)
 • 20 m (65.6 ft)
 • 30 m (98.4 ft)
 Advanced version integral on sensor
 Advanced version, remote cables mounted on sensor with IP68/NEMA 6P plugs:
 • 5 m (16.4 ft)
 • 10 m (32.8 ft)
 • 20 m (65.6 ft)
 • 30 m (98.4 ft)

A
 B
 C
 D
 E
 K
 L
 M
 N
 P

Communication interface

No additional "add-on" communication module installed
 Serial RS 485 with Modbus RTU (Terminated as end device)
 Serial RS 232 with Modbus RTU
 Encoder interface with Sensus protocol
 3G/UMTS communication module with remote antenna; 5 m (16.4 ft) cable
 3G/UMTS communication module with analog inputs and remote antenna; 5 m (16.4 ft) cable

A
 B
 C
 D
 S
 T

Power supply

Internal battery (no battery included)
 Internal battery pack installed¹⁾
 Power cable (1.5 m (4.9 ft)) with IP68/NEMA 6P plugs for external battery (no battery included)
 12/24 V AC/DC power supply with battery backup and 3 m (9.8 ft) power cable for external connection (no battery included)
 115 ... 230 V AC power supply with battery backup and 3 m (9.8 ft) power cable for external connection (no battery included)

0
 1
 2
 3
 4

- The Diameter DN 700 (28") to DN 1200 (48") is only available as remote transmitter type installation.
- Lithium batteries are subject to special transportation regulations according to United Nations "Regulation of Dangerous Goods, UN 3090 and UN 3091". Special transport documentation is required to observe these regulations. This may influence both transport time and costs.

MAG 8000 for abstraction and distribution network application (7ME6810)

Selection and ordering data	Order code	Additional information	Order code
Additional information		Additional information	
Please add "-Z" to Article No. and specify Order code(s) and plain text.		Please add "-Z" to Article No. and specify Order code(s) and plain text.	
Certificate		Volume unit	
Material certificate according to EN 10204-3.1 ¹⁾	C12	m ³	L40
Special calibration		MI	L41
5-point calibration for DN 15 ... DN 200 ²⁾	D01	G	L42
5-point calibration for DN 250 ... DN 600 ²⁾	D02	AF	L43
5-point calibration for DN 700 ... DN 1200 ²⁾	D03	l x 100	L44
10-point calibration for DN 15 ... DN 200 ³⁾	D06	m ³ x 100	L45
10-point calibration for DN 250 ... DN 600 ³⁾	D07	G x 100	L46
10-point calibration for DN 700 ... DN 1200 ³⁾	D08	CF x 100	L47
Default (2 x 25 % and 2 x 90 %) match-pair calibration for DN 15 ... DN 200	D11	MG	L48
Default (2 x 25 % and 2 x 90 %) match-pair calibration for DN 250 ... DN 600	D12	G x 1000	L49
Default (2 x 25 % and 2 x 90 %) match-pair calibration for DN 700 ... DN 1200	D13	CF x 1000	L50
5-point, matched-pair calibration for DN 15 ... DN 200 ²⁾	D15	AI	L51
5-point, matched-pair calibration for DN 250 ... DN 600 ²⁾	D16	kl	L52
5-point, matched-pair calibration for DN 700 ... DN 1200 ²⁾	D17	BBL42 (US oil barrel, 1 barrel = 42 US gallons)	L54
10-point, matched-pair calibration for DN 15 ... DN 200 ³⁾	D18	Pulse set up	
10-point, matched-pair calibration for DN 250 ... DN 600 ³⁾	D19	(default pulse A = forward and pulse B = Alarm, pulse width = 50 ms)	
10-point, matched-pair calibration for DN 700 ... DN 1200 ³⁾	D20	A function = RV, reverse flow	L62
Flow unit		A function = FWnet, forward net flow	L63
l/s	L00	A function = RVnet, reverse net flow	L64
MGD	L01	A function = Off	L65
CFS	L02	Volume per pulse A = x 0.0001 ⁴⁾	L70
l/min	L03	Volume per pulse A = x 0.001 ⁴⁾	L71
m ³ /min	L04	Volume per pulse A = x 0.01 ⁴⁾	L72
GPM	L05	Volume per pulse A = x 0.1 ⁴⁾	L73
CFM	L06	Volume per pulse A = x 1 ⁴⁾	L74
l/h	L07	Pulse A pulse width 5 ms (volume per pulse x 1)	L75
m ³ /h	L08	Pulse A pulse width 10 ms (volume per pulse x 1)	L76
GPH	L09	Pulse A pulse width 50 ms (volume per pulse x 1)	L77
CFH	L10	Pulse A pulse width 100 ms (volume per pulse x 1)	L78
GPS	L11	Pulse A pulse width 500 ms (volume per pulse x 1)	L79
MI/d	L12	B function = FW, forward flow	L80
m ³ /d	L13	B function = RV, reverse flow	L81
GPD	L14	B function = FWnet, forward net flow	L82
BBL42/s	L15	B function = RVnet, reverse net flow	L83
BBL42/min	L16	B function = Alarm	L84
BBL42/h	L17	B function = Call up	L85
BBL42/d	L18	Volume per pulse B = x 0.0001 ⁴⁾	L90
Totalizer		Volume per pulse B = x 0.001 ⁴⁾	L91
Volume calculation (default totalizer 1= forward and totalizer 2 = reverse)		Volume per pulse B = x 0.01 ⁴⁾	L92
Totalizer 1 = RV, reverse flow	L20	Volume per pulse B = x 0.1 ⁴⁾	L93
Totalizer 1 = NET, net flow	L22	Volume per pulse B = x 1 ⁴⁾	L94
Totalizer 2 = FW, forward flow	L30	Device operation	
Totalizer 2 = NET, net flow	L31	Only operator menu activated	M11
		Data logger set up (default month logging)	
		DataloggerInterval = Daily	M31
		DataloggerInterval = Weekly	M32
		Factory mounted cables	
		5 m (16.4 ft) pulse cable A+B	M81
		5 m (16.4 ft) communication cable RS 232/RS 485 terminated as end device	M82

Flow Measurement

SITRANS FM

MAG 8000 for abstraction and distribution network application (7ME6810)

Selection and ordering data	Order code
Additional information	
Please add "-Z" to Article No. and specify Order code(s) and plain text.	
20 m (65.6 ft) pulse cable A+B	M84
20 m (65.6 ft) communication cable RS 232/RS 485 terminated as end device	M85
Cello 2 channel, input cable 3 m (9.84 ft) with Brad Harrison micro-change 3 way connector	M87
Cello 2 channel, input cable 5 m (16.4 ft) with MIL-C-26482 spec. connectors	M89
Encoder interface cable with connector for ITRON 200WP radio, length 25 ft	M90
Encoder interface cable with connector for ITRON 200WP radio, length 5 ft	M91
SOFREL cable 2 m for LS42 data logger	M92
Adaptors for conduit installation	M94
SOFREL cable 2 m for LS-Flow data logger	M97
FM Fire Service Approval	
(with ANSI B16.5 Class 150 flanges)	
DN 50, DN 80 and DN 100 (2", 3" and 4")	P20
DN 150 and DN 200 (6" and 8")	P21
DN 250 and DN 300 (10" and 12")	P22
Region/customer specific labels	
KCC label (South Korea)	W28
DIN 43863 label ¹⁾	H21
DIN 43863 label with SWM mark ¹⁾	H22

¹⁾ Under preparation

²⁾ 20 %, 40 %, 60 %, 80 %, 100 % of factory Q_{max}

³⁾ Ascending and descending at 20 %, 40 %, 60 %, 80 %, 100 % of factory Q_{max}

⁴⁾ Pulse width = 10 ms

Operating instructions for SITRANS F M MAG 8000

Description	Article No.
• English	A5E03071515
• German	A5E00740986

All literature is available to download for free, in a range of languages, at

<http://www.siemens.com/processinstrumentation/documentation>

Operating instructions for MAG 8000 3G/UMTS communication module

Description	Article No.
• English	A5E03644134

Overview

Benefits
Approvals

- MI-001, OIML R 49/OIML R 49 MAA
- FM Fire Service

Easy to install

- Compact or remote solution with factory mounted cable and customer setting from factory
- IP68/NEMA 6P enclosure. Sensor can be buried.
- Flexible power supply - internal or external battery pack or mains power supply with battery back-up possibilities

Long-term stability/Low cost of ownership

- No moving parts in a robust construction means less wear and tear
- Basic and advanced transmitter versions with different optional add-on communication modules fulfil various customer requirements for high cost efficiency
- Bi-directional measurement with an outstanding low flow performance
- Up to 10 years maintenance-free operation in typical applications
- Insignificant pressure drop

Intelligent information, easy to access

- Advanced information on site
- Advanced statistics and diagnostics
- Connectable to common AMR systems

Flow Measurement

SITRANS FM

MAG 8000 CT for revenue and bulk metering (7ME6820)

Technical specifications

Meter	
Accuracy	OIML R 49/OIML R 49 MAA accuracy class I for DN 50, DN 350 ... DN 600 accuracy class II for DN 50 ... DN 600 MI-001 verification for DN 50 ... DN 600 (2" ... 24"), with Q3/Q1 = 315 FM Fire Service for DN 50, DN 80, DN 100, DN 150, DN 200, DN 250, and DN 300 (2", 3", 4", 6", 8", 10", and 12") ± 1,5 % (Q _{min} to Q _{max})
Low flow cut-off (default)	15 mm/s
Media conductivity	Clean water > 20 µs/cm
Temperature	
Ambient	-20 ... +60 °C (-4 ... +140 °F) MI-001: -25 ... +55 °C (-13 ... +131 °F)
Media	0.1 ... 50 °C (32 ... 122 °F)
Storage	-40 ... +70 °C (-22 ... +158 °F)
Enclosure rating	
Remote sensor	IP68 to EN 60529/NEMA 6P, 10 mH ₂ O cont.
Compact version	IP68 to EN 60529/NEMA 6P, 3 mH ₂ O for six months
Certificates and approvals	
Calibration (standard)	2 × 25 % and 2 × 90 %
Material certificate EN 10204-3.1	Available when ordering together with meter ¹⁾
Drinking water approvals	<ul style="list-style-type: none"> • NSF/ANSI Standard 61²⁾ (cold water) USA • WRAS (BS 6920 cold water) UK • ACS Listed France • DVGW W270 Germany • Belgaqua (B) • MCERTS (GB)
Fire Service approval	FM Fire Service (1044) ³⁾
Custody transfer approval	<ul style="list-style-type: none"> • OIML R 49 and OIML R 49 MAA approval • MI-001 approval (DK-0200-MI001-011) • CEN EN 14154, ISO 4064 • PED: 2014/68/EU⁴⁾
Conformity	For pressure/temperature curves see MAG 3100 on page 3/xx <ul style="list-style-type: none"> • EMC: IEC/EN 61326 • CRN (DN 50 ... DN 1200 (2" ... 48"))

Meter	
Sensor version	DN 50 ... 600 (2" ... 24")
Sensor material	Carbon steel ASTM A 105, with corrosion resistant two-component epoxy coating (150 µm/300 µm) Corrosivity category C4M, according to ISO 12944
Measuring principle	Electromagnetic induction
Excitation frequency	
Basic version	
• Battery-powered	DN 50 ... 150 (2" ... 6"): 1/15 Hz DN 200 ... 600 (8" ... 24"): 1/30 Hz
• Mains-powered	DN 50 ... 150 (2" ... 6"): 6.25 Hz DN 200 ... 600 (8" ... 24"): 3.125 Hz
Advanced version	
• Battery-powered	DN 50 ... 150 (2" ... 6"): 1/15 Hz (adjustable up to 6.25 Hz; reduced battery lifetime) DN 200 ... 600 (8" ... 24"): 1/30 Hz (adjustable up to 3.125 Hz; reduced battery lifetime)
• Mains-powered	DN 50 ... 150 (2" ... 6"): 6.25 Hz DN 200 ... 600 (8" ... 24"): 3.125 Hz
Flanges	
EN 1092-1 (DIN 2501)	DN 50 ... 150 (2" ... 6"): PN 16 (232 psi) DN 200 ... 300 (8" ... 12"): PN 10 or PN 16 (145 psi or 232 psi) up to DN 600 (24") in preparation
ANSI 16.5 Class 150	2" ... 12": 20 bar (290 psi) up to DN 600 (24") in preparation
AWWA C-207	28" ... 48": PN 10 (145 psi)
AS 4087	DN 50 ... 300 (2" ... 12"): PN 16 (232 psi) up to DN 600 (24") in preparation
Liner	EPDM
Electrode and grounding electrodes	Hastelloy C276/2.4819
Grounding straps	Grounding straps are premounted from the factory on each side of the sensor.

¹⁾ Has to be ordered with the meter. It is not possible to order the certificate afterwards.

²⁾ Including Annex G

³⁾ Not for sensors with 300 m coating.

⁴⁾ For further information on the PED standard and requirements see page 9/6.

Technical specifications (continued)**MAG 8000 CT (Revenue program) water meter type approval**

MAG 8000 CT program is type approved and verified according to international water meter standard OIML R 49.

The custody transfer program is approved as Class 1 (DN 50, DN 350 ... DN 600) and Class 2 (DN 50 ... DN 600), at different Q3 and Q3/Q1, according to OIML R 49:2013 specification.

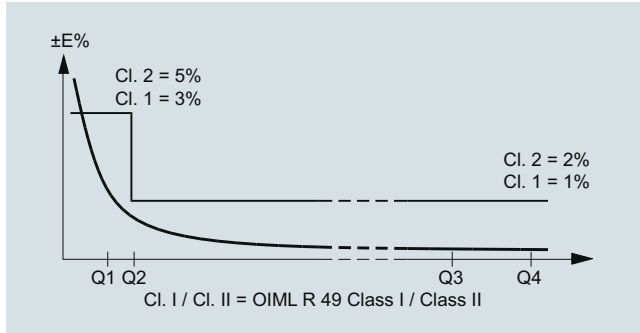

OIML R 49:2013 specification for Class 1¹⁾

7ME6820	DN 50 (2")	DN 350 (14")	DN 400 (16")	DN 450 (18")	DN 500 (20")	DN 600 (24")
R (Q3/Q1)	200	125	125	125	125	125
Q4 [m ³ /h]	78.75	3125	5000	5000	7875	7875
Q3 [m³/h]	63	2500	4000	4000	6300	6300
Q2 [m ³ /h]	0.504	32	51.200	51.200	80.640	80.640
Q1 [m ³ /h]	0.315	20	32	32	50.400	50.400

OIML R 49:2013 specification for Class 2¹⁾

7ME6820	Horizontal installation													
	DN 50 (2")	DN 65 (2½")	DN 80 (3")	DN 100 (4")	DN 125 (5")	DN 150 (6")	DN 200 (8")	DN 250 (10")	DN 300 (12")	DN 350 (14")	DN 400 (16")	DN 450 (18")	DN 500 (20")	DN 600 (24")
R (Q3/Q1)	315	315	315	315	315	315	315	315	315	200	200	200	200	200
Q4 [m ³ /h]	78.75	125	200	312.50	500	787.50	1250	2000	2000	3125	5000	5000	7875	7875
Q3 [m³/h]	63	100	160	250	400	630	1000	1600	1600	2500	4000	4000	6300	6300
Q2 [m ³ /h]	0.320	0.508	0.813	1.270	2.032	3.200	5.079	8.127	8.127	20	32	32	50.400	50.400
Q1 [m ³ /h]	0.200	0.317	0.508	0.794	1.270	2	3.175	5.079	5.079	12.500	20	20	31.500	31.500

¹⁾ The product will be delivered according to requested specifications, which may deviate from the specifications of the approval frame described in tables below.

Flow Measurement

SITRANS FM

MAG 8000 CT for revenue and bulk metering (7ME6820)

Technical specifications (continued)

MAG 8000 CT (Revenue program) MI-001

MAG 8000 CT program is type approved according to international water meter standard OIML R 49. Since the first November 2006 the MI-001 water meter directive is in force, which means that all water meters can be sold across the EU borders if the water meters contain a MI-001 label.

The MAG 8000 CT MI-001 verified and labeled products are a Class II approval according to Directive 2014/32/EU of the European Parliament and Council of 26 February, 2014 on measuring instruments, Annex III Water meters (MI-001) in the sizes from DN 50 to DN 600.

The MID certification is obtained as a B + D module approval according to the above mentioned directive.

Module B: Type approval according to OIML R 49

Module D: Quality insurance approval of production

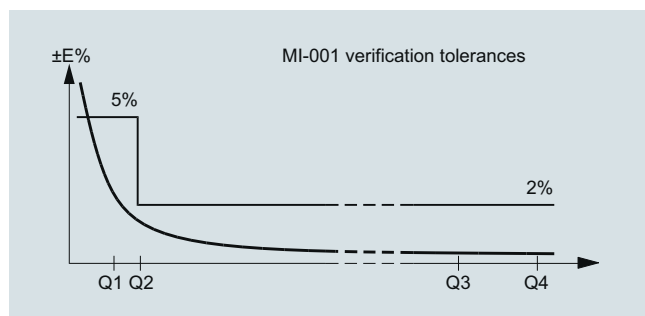

MAG 8000 CT MI-001 verified and labeled products at a given $Q3$ and $Q4/Q3 = 1.25$ and $Q2/Q1 = 1.6$ measuring ranges see below table:

Horizontal installation														
7ME6820-xxxx1	DN 50 (2")	DN 65 (2½")	DN 80 (3")	DN 100 (4")	DN 125 (5")	DN 150 (6")	DN 200 (8")	DN 250 (10")	DN 300 (12")	DN 350 (14")	DN 400 (16")	DN 450 (18")	DN 500 (20")	DN 600 (24")
R (Q3/Q1)	40	40	40	40	40	40	40	40	40	40	40	40	40	40
Q4 [m³/h]	20	31.25	50	78.75	125	200	312.50	500	787.50	787.50	1250	1250	2000	2000
Q3 [m³/h]	16	25	40	63	100	160	250	400	630	630	1000	1000	1600	1600
Q2 [m³/h]	0.640	1	1.600	2.520	4	6.400	10	16	25.200	25.200	40	40	64	64
Q1 [m³/h]	0.400	0.625	1	1.575	2.500	4.000	6.250	10	15.750	15.750	25	25	40	40

Horizontal installation														
7ME6820-xxxx2	DN 50 (2")	DN 65 (2½")	DN 80 (3")	DN 100 (4")	DN 125 (5")	DN 150 (6")	DN 200 (8")	DN 250 (10")	DN 300 (12")	DN 350 (14")	DN 400 (16")	DN 450 (18")	DN 500 (20")	DN 600 (24")
R (Q3/Q1)	63	63	63	63	63	63	63	63	63	63	63	63	63	63
Q4 [m³/h]	20	31.25	50	79	125	200	312.50	500	788	1250	3125	3125	3125	3125
Q3 [m³/h]	16	25	40	63	100	160	250	400	630	1000	2500	2500	2500	2500
Q2 [m³/h]	0.406	0.635	1.016	1.600	2.540	4.063	6.349	10.159	16	25.397	63.492	63.492	63.492	63.492
Q1 [m³/h]	0.254	0.397	0.635	1	1.587	2.540	3.968	6.349	10	15.873	39.683	39.683	39.683	39.683

Technical specifications (continued)

Horizontal installation														
7ME6820-xxxx3	DN 50 (2")	DN 65 (2½")	DN 80 (3")	DN 100 (4")	DN 125 (5")	DN 150 (6")	DN 200 (8")	DN 250 (10")	DN 300 (12")	DN 350 (14")	DN 400 (16")	DN 450 (18")	DN 500 (20")	DN 600 (24")
R (Q3/Q1)	80	80	80	80	80	80	80	80	80	80	80	80	80	80
Q4 [m³/h]	31.25	50	79	125	200	312.50	500	788	1250	2000	2000	3125	5000	5000
Q3 [m³/h]	25	40	63	100	160	250	400	630	1000	1600	1600	2500	4000	4000
Q2 [m³/h]	0.500	0.800	1.260	2	3.200	5	8	12.600	20	32	32	50	80	80
Q1 [m³/h]	0.313	0.500	0.788	1.250	2	3.125	5	7.875	12.500	20	20	31.250	50	50

Horizontal installation														
7ME6820-xxxx4	DN 50 (2")	DN 65 (2½")	DN 80 (3")	DN 100 (4")	DN 125 (5")	DN 150 (6")	DN 200 (8")	DN 250 (10")	DN 300 (12")	DN 350 (14")	DN 400 (16")	DN 450 (18")	DN 500 (20")	DN 600 (24")
R (Q3/Q1)	160	160	160	160	160	160	160	160	160	160	160	160	160	160
Q4 [m³/h]	50	79	125	200	312.50	500	788	1250	2000	3125	5000	5000	7875	7875
Q3 [m³/h]	40	63	100	160	250	400	630	1000	1600	2500	4000	4000	6300	6300
Q2 [m³/h]	0.400	0.630	1	1.600	2.500	4	6.300	10	16	25	40	40	63	63
Q1 [m³/h]	0.250	0.394	0.625	1	1.563	2.500	3.938	6.250	10	15.625	25	25	39.375	39.375

Horizontal installation														
7ME6820-xxxx5	DN 50 (2")	DN 65 (2½")	DN 80 (3")	DN 100 (4")	DN 125 (5")	DN 150 (6")	DN 200 (8")	DN 250 (10")	DN 300 (12")	DN 350 (14")	DN 400 (16")	DN 450 (18")	DN 500 (20")	DN 600 (24")
R (Q3/Q1)	200	200	200	200	200	200	200	200	200	200	200	200	200	200
Q4 [m³/h]	78.75	125	200	312.50	500	787.50	1250	2000	2000	3125	5000	5000	7875	7875
Q3 [m³/h]	63	100	160	250	400	630	1000	1600	1600	2500	4000	4000	6300	6300
Q2 [m³/h]	0.504	0.800	1.280	2	3.200	5.040	8	12.800	12.800	20	32	32	50.400	50.400
Q1 [m³/h]	0.315	0.500	0.800	1.250	2	3.150	5	8	8	12.500	20	20	31.500	31.500

Horizontal installation										
7ME6820-xxxx6	DN 50 (2")	DN 65 (2½")	DN 80 (3")	DN 100 (4")	DN 125 (5")	DN 150 (6")	DN 200 (8")	DN 250 (10")	DN 300 (12")	
R (Q3/Q1)	250	250	250	250	250	250	250	250	250	250
Q4 [m³/h]	78.75	125	200	312.50	500	787.50	1250	2000	2000	2000
Q3 [m³/h]	63	100	160	250	400	630	1000	1600	1600	1600
Q2 [m³/h]	0.403	0.640	1.024	1.600	2.560	4.032	6.400	10.240	10.240	10.240
Q1 [m³/h]	0.252	0.400	0.640	1	1.600	2.520	4	6.400	6.400	6.400

The Label is placed on the side of the encapsulation. An example of the product label is shown below:

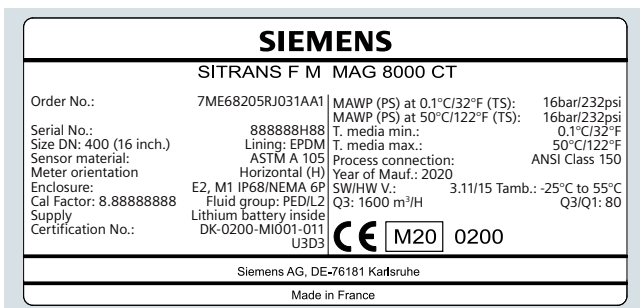

Installation conditions

Please refer to "System information SITRANS FM electromagnetic flowmeters".

Battery operation time and calculation

The battery operation time depends on the connected battery pack as well as the operation condition of the meter.

MAG 8000 calculates the remaining capacity every 4 hours and includes all consuming elements. Calculation compensates for temperature influence on battery capacity (drawing).

MAG 8000 CT (7ME6820) for Fire Service applications

MAG 8000 CT (7ME6820) is FM Fire Service approved for automatic fire protection systems according to the Fire Service Meters Standard, Class Number 1044. The approval is applicable for the sizes 50, DN 80, DN 100, DN 150, DN 200, DN 250, and DN 300 (2", 3", 4", 6", 8", 10", and 12") with ANSI B16.5 Class 150 flanges. The FM Fire Service approved product can be ordered via the Z-options P20, P21 and P22.

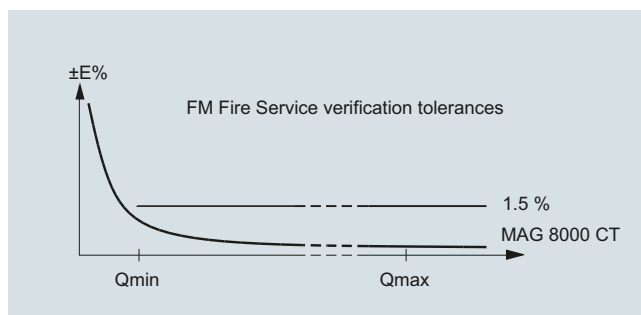

Flow Measurement

SITRANS FM

MAG 8000 CT for revenue and bulk metering (7ME6820)

Selection and ordering data

Article No.

SITRANS FM

MAG 8000 CT water meter with EPDM liner and Hastelloy electrodes

Click on the Article No. for the online configuration in the PIA Life Cycle Portal.

Diameter

DN 50 (2")

2 Y

DN 65 (2½")

3 F

DN 80 (3")

3 M

DN 100 (4")

3 T

DN 125 (5")

4 B

DN 150 (6")

4 H

DN 200 (8")

4 P

DN 250 (10")

4 V

DN 300 (12")

5 D

DN 350 (14")¹⁾

5 K

DN 400 (16")¹⁾

5 R

DN 450 (18")¹⁾

5 Y

DN 500 (20")¹⁾

6 F

DN 600 (24")¹⁾

6 P

Flange norm and pressure rating

EN 1092-1

PN 16

C

ANSI B16.5

Class 150

J

AS4087

PN 16

N

Sensor version

EPDM liner and Hastelloy electrodes, corrosion-resistant coating of category C4

0

EPDM liner and Hastelloy electrodes, 300 mm coating

4

Approval/Verification³⁾

Without verification according to OIML R 49⁴⁾

0

MI-001 Q3/Q1 = 40

1

MI-001 Q3/Q1 = 63

2

MI-001 Q3/Q1 = 80

3

MI-001 Q3/Q1 = 160

4

MI-001 Q3/Q1 = 200

5

MI-001 Q3/Q1 = 250

6

Without verification calibrated to OIML R 49-Class II (Q3/Q1 = 100)

7

Without verification calibrated to OIML R 49-Class II (Q3/Q1 = 250)

8

Region version

Europe (m³, m³/h, 50 Hz)

1

USA (m³, m³/h, 60 Hz)

2

SITRANS FM

MAG 8000 CT water meter with EPDM liner and Hastelloy electrodes

Transmitter type and installation

Basic version integral on sensor

A

Basic version, remote cables mounted on sensor with IP68/NEMA 6P plugs

B

5 m (16.4 ft)

C

10 m (32.8 ft)

D

20 m (65.6 ft)

E

30 m (98.4 ft)

K

Advanced version integral on sensor

L

Advanced version, remote cables mounted on sensor with IP68/NEMA 6P plugs

M

5 m (16.4 ft)

N

10 m (32.8 ft)

P

20 m (65.6 ft)

30 m (98.4 ft)

Communication interface

No additional "add-on" communication module installed

A

Serial RS 485 with Modbus RTU (Terminated as end device)

B

Serial RS 232 with Modbus RTU

C

Encoder interface for ITRON 200WP radio with "Sensus" protocol"

D

3G/UMTS communication module with remote antenna; 5 m (16.4 ft) cable

S

3G/UMTS communication module with analog inputs and remote antenna; 5 m (16.4 ft) cable

T

Power supply

Internal battery (no battery included)

0

Internal battery pack installed²⁾

1

Power cable (1.5 m (4.9 ft)) with IP68/NEMA 6P plugs for external battery (no battery included)

2

12/24 V AC/DC power supply with battery backup and 3 m (9.8 ft) power cable for external connection (no battery included)

3

115 ... 230 V AC power supply with battery backup and 3 m (9.8 ft) power cable for external connection (no battery included)

4

¹⁾ Under preparation.

²⁾ Lithium batteries are subject to special transportation regulations according to United Nations "Regulation of Dangerous Goods, UN 3090 and UN 3091". Special transport documentation is required to observe these regulations. This may influence both transport time and costs.

³⁾ For more details and references of the ranges please see the tables on pages 3/xxx to 3/xxx.

⁴⁾ Standard calibration or according to FM Fire Service requirements if P20, P21 or P22 is selected as Z option.

Selection and ordering data	Order code	Order code
Additional information		Additional information
Please add "-Z" to Article No. and specify Order code(s) and plain text.		Please add "-Z" to Article No. and specify Order code(s) and plain text.
Material certificate according to EN 10204-3.1 ¹⁾	C12	FM Fire Service Approval
FP2E marking (France only)	C17	(with ANSI B16.5 Class 150 flanges)
Totalizer		DN 50, DN 80 and DN 100 (2", 3" and 4")
Volume calculation (default totalizer 1 = forward and totalizer 2 = reverse)		P20
Totalizer 1 = RV, reverse flow	L20	DN 150 and DN 200 (6" and 8")
Totalizer 1 = NET, net flow	L22	P21
Totalizer 2 = FW, forward flow	L30	DN 250 and DN 300 (10" and 12")
Totalizer 2 = NET, net flow	L31	P22
Pulse set up		Region/customer specific label
(default pulse A = forward and pulse B = Alarm, pulse width = 50 ms)		KCC label (South Korea)
A function = RV, reverse flow	L62	W28
A function = FWnet, forward net flow	L63	FP2E label (France)
A function = RVnet, reverse net flow	L64	H20
A function = Off	L65	DIN 43863 label ¹⁾
Volume per pulse A = x 0.001 ²⁾	L71	H21
Volume per pulse A = x 0.01 ²⁾	L72	H22
Volume per pulse A = x 0.1 ²⁾	L73	DIN 43863 label with SWM mark ¹⁾
Volume per pulse A = x 1 ²⁾	L74	1) Under preparation
B function = FW, forward flow	L80	2) Pulse width = 10 ms
B function = RV, reverse flow	L81	
B function = FWnet, forward net flow	L82	
B function = RVnet, reverse net flow	L83	
B function = Alarm	L84	
B function = Call up	L85	
Volume per pulse B = x 0.001 ²⁾	L91	
Volume per pulse B = x 0.01 ²⁾	L92	
Volume per pulse B = x 0.1 ²⁾	L93	
Volume per pulse B = x 1 ²⁾	L94	
Data logger set up (default month logging)		
DataloggerInterval = Daily	M31	
DataloggerInterval = Weekly	M32	
Factory mounted cables		
5 m (16.4 ft) pulse cable A+B	M81	
5 m (16.4 ft) communication cable RS 232/RS 485 terminated as end device	M82	
20 m (65.6 ft) pulse cable A+B	M84	
20 m (65.6 ft) communication cable RS 232/RS 485 terminated as end device	M85	
Cello 2 channel, input cable 3 m (9.84 ft) with Brad Harrison micro-change 3 way connector	M87	
Cello 2 channel, input cable 5 m (16.4 ft) with MIL-C-26482 spec. connectors	M89	
5 ft. Encoder interface cable with connector for ITRON 200WP radio	M91	
25 ft. Encoder interface cable with connector for ITRON 200WP radio	M90	
SOFREL cable 2 m for LS42 data logger	M92	
SOFREL cable 2 m for LS-Flow data logger	M97	

Operating instructions for SITRANS FM MAG 8000

Description	Article No.
• English	A5E03071515
• German	A5E00740986

All literature is available to download for free, in a range of languages, at
<http://www.siemens.com/processinstrumentation/documentation>

Operating instructions for MAG 8000 3G/UMTS communication module

Description	Article No.
• English	A5E03644134

Flow Measurement

SITRANS FM

MAG 8000 3G/UMTS Wireless Communication Module

Overview



3G/UMTS communication module



PC-IrDA connection

MAG 8000 3G/UMTS Wireless Communication Module

The 3G/UMTS wireless communication module is a compact built-in solution which can be installed in the existing MAG 8000 with SW version 3.02 and higher, supporting HSDPA cat. 8/HSUPA Cat.6 at 5 UMTS bands, with the ability to fall back to GSM/GPRS network in case there is no 3G signal.

The 3G/UMTS module collects comprehensive measurement data from MAG 8000 at an interval down to 1 minute, allows for data transmission via numerous protocols including SMS, email via SMTP, email via SMTPS (TLS/SSL-based encryption), FTP, and FTPS (TLS/SSL-based encryption, implicit), with a customer configurable transmission interval (down to 1 hour). This provides customers with the flexibility to receive data via email, FTP or text message for the monitoring and control systems anywhere in the world.

TLS/SSL based data encryption provides a high level information security to protect customers data privacy.

The 3G/UMTS module offers

- Remote Qualification Certificate feature to enable the offsite diagnostic and audit on devices installed anywhere in the world
- 2-channel analog input measurement for external ratiometric pressure transmitter, transmission together with flow measurement (2-in-1 solution)
- 4-20 mA alarm signal detection and realtime SMS alarm for tamper protection and flooding situations
- Real-time clock synchronization with internet NTP server, ensuring that all measurement data is accurately time-stamped
- Data transmission at customer-specified points in time, allowing for synchronization of information from multiple MAG 8000 devices

The OPC server specifically designed for the MAG 8000 3G/UMTS module is offered free of charge. With this value-added package, the opportunity for measurement data collection and further processing/analyzing for system integration and automation is offered.

The package of information retrieved via the csv file includes:

- Time stamp
- Flow rate
- Tot 1
- Tot 2
- Tot 3
- Analog 1 (mA)
- Analog 2 (V)
- Battery lifetime
- Alarm list (as decimal format)

Circuit diagrams

Electrical installation of 3G/UMTS module



- 1 SIM card slot
- 2 3G module's antenna connector
- 3 Analog inputs inlet
- 4 Rechargeable battery inlet

Selection and ordering data

Accessories



Description	Article No.		Description	Article No.	
PC Flow Tool on CD (Download for free from http://www.siemens.com/flow)	FDK:087L6001		One cable entry 2 ... 5 mm (0.08 ... 0.20 ") M12 brass glands with M20 reduction ²⁾ . Package of 10 pcs, for 3G/UMTS module antenna cable, power cable of external battery pack, encoder card cable.	FDK:087L4154	
IrDA infrared interface adapter with USB for data acquisition with 1.2 m (3.9 ft) cable	FDK:087L4163		One cable entry 6 ... 8 mm (0.24 ... 0.31 ") M20 brass glands pack- age ²⁾ (10 pcs), for pulse output cable or MODBUS cable, Cello cable or mains power supply	FDK:087L4155	
Battery backup for mains power supply, 1 pc. D-cell (3.6 V, 16.5 Ah) ¹⁾	A5E03354392		One cable entry 8 ... 11 mm (0.31 ... 0.43 ") M20 brass glands package ²⁾ (10 pcs), for SOFREL cable	FDK:087L4156	
Rechargeable Lithium battery for MAG 8000 3G/UMTS communi- cation module ¹⁾	A5E03436686		One cable entry 11 ... 15 mm (0.43 ... 0.59 ") M20 brass glands package ²⁾ (10 pcs)	FDK:087L4157	
Internal battery pack, one set of 2 D-cell (3.6 V, 33 Ah) and accesso- ries for replacement ¹⁾ incl. NBR O-ring	FDK:087L4150		Two cable entries 3.5 ... 5 mm (0.14 ... 0.20 ") M20 brass glands package ²⁾ (10 pcs)	FDK:087L4158	
External battery pack IP68/ NEMA 6P with connector, 4 D-cell (3.6 V, 66 Ah) ¹⁾ . Order cable FDK:087L4152 separately.	FDK:087L4151		Two cable entries 5.5 ... 7.5 mm (0.22 ... 0.30 "), M20 brass glands package ²⁾ (10 pcs)	FDK:087L4159	
Mains power supply 12 ... 24 V AC/DC (average power consumption during line ≤ 0.1 VA) with battery backup and 3 m (9.8 ft) power cable for exter- nal connection (no battery included) Temperature range: Fixed laying: -40 ... +90 °C (-40 ... +194 °F) Flexible application: -30 ... +80 °C (-22 ... +176 °F)	FDK:087L4210		High gain antenna for MAG 8000 3G/UMTS (PVC, IP68, cable length 5 m (16.4 ft), with SMA male connector (type RG 58) and internal antenna adaptor cable, and single entry cable gland)	A5E40957990	
Mains power supply 115 ... 230 V AC, 50/60 Hz, with battery backup up and 3 m (9.8 ft) power cable for external connection (no battery included)	FDK:087L4211		Analog input cable for MAG 8000 3G/UMTS (2.5 m (8.2 ft) cable with M12 connector A-Coding female 5 pins, and two-entry cable gland)	A5E03436698	
RS 232 add-on module, point to point communication interface with Modbus RTU protocol	FDK:087L4212		Potting kit for terminal box of flow sensors for IP68/NEMA 6P	FDK:085U0220	
RS 485 add-on module, multidrop communication interface with Modbus RTU protocol	FDK:087L4213		MAG 8000 Hardware key to access protected parameters	FDK:087L4165	
Encoder interface module, with "Sensus" protocol for ITRON 200WP and 100W radio	A5E02475650		MAG 8000 demo - training unit pack operating on Alkaline batter- ies. Transmitter with Flow tool CD, IrDA interface adapter and hard- ware key (No dangerous goods limitations)	FDK:087L4080	
MAG 8000 3G/UMTS module. Rechargeable battery, antenna and analog cable input must be ordered separately	A5E41011589		Antenna adaptor cable for 3G/UMTS module (2 pieces)	A5E41896494	

Flow Measurement

SITRANS FM

Accessories and spare parts for MAG 8000

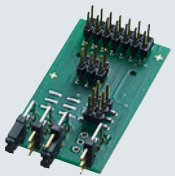
Selection and ordering data (continued)

Description	Article No.	
Service adaptor for 3G/UMTS module	A5E03436699	
Alkaline battery for MAG 8000 demo transmitter (3 V 13 Ah) (No dangerous goods limitations)	FDK:087L4142	

¹⁾ Lithium batteries are subject to special transportation regulations according to United Nations "Regulation of Dangerous Goods, UN 3090 and UN 3091". Special transport documentation is required to observe these regulations. This may influence both transport time and costs.









²⁾ For cable connection through MAG 8000 transmitter bottom part.

When MAG 8000 (7ME6810 and 7ME6820) is installed in PVC or coated pipelines, grounding rings must be installed additionally.

Grounding rings, type C must be used for the 7ME6810 and 7ME6820 routes (sizes > DN 300). Please see grounding rings in the section MAG 3100 Grounding rings and be aware that the mentioned MLFB codes include only 1 grounding ring. Grounding rings DN 25 to DN 300 in stainless steel are packed in pairs and sold as a "grounding ring kit".

Dimension	Article No.	
DN 25	A5E01002946	
DN 40	A5E01002947	
DN 50	A5E01002948	
DN 65	A5E01002950	
DN 80	A5E01002952	
DN 100	A5E01002953	
DN 125	A5E01002954	
DN 150	A5E01002955	
DN 200	A5E01002957	
DN 250	A5E01002958	
DN 300	A5E01002962	

Spare parts

Description	Article No.	
MAG 8000 transmitter compact replacement kit ¹⁾ . No battery included. With original product label. System number specified by ordering	FDK:087L4166	
MAG 8000 transmitter remote replacement kit ¹⁾ . No battery included. With original product label. System number specified by ordering	FDK:087L4202	
MAG 8000 (Advanced version) transmitter compact replacement kit ¹⁾ . No battery included. With blank product label. No system number required	FDK:087L4203	
MAG 8000 (Advanced version) transmitter remote replacement kit ¹⁾ . No battery included No system number required	FDK:087L4204	
MAG 8000 (Basic version) transmitter PCB replacement kit ¹⁾ . No system number required	A5E01171569	
MAG 8000 (advanced version) transmitter PCB replacement kit ¹⁾ . No system number required	FDK:087L4168	
Enclosure top including plastic lid, screws, O-ring and blank product label	FDK:087L4167	
Power cable 1.5 m (4.9 ft) with IP68/NEMA 6P plugs for external battery (no battery included); PE jacket, ambient temperature: -20 °C ... +60 °C (-4 °F ... 140 °F)	FDK:087L4152	

Selection and ordering data (continued)

Description	Article No.	
Encoder interface cable with IP68/NEMA 6P plugs included, for ITRON 200WP and 100W radio; 22 AWG stranded TC conductors, polypropylene insulation, twisted pair, overall Beldfoil shield, 22 AWG stranded TC drain wire, PVC jacket Length: 152.4 cm (5 ft)	A5E02551263	
Encoder interface cable with IP68/NEMA 6P plugs included, for ITRON 200WP radio; 22 AWG stranded TC conductors, polypropylene insulation, twisted pair, overall Beldfoil shield, 22 AWG stranded TC drain wire, PVC jacket Length: 762 cm (25 ft)	A5E02551182	
Service tool kit package with various component for service and replacement. Content: 10 × plastic top lids 20 × screws 10 × wire holders 10 × battery cups 10 × greased O-rings 20 × clamp kits 10 × IrDA adaptor holding rings	FDK:087L4162	
Remote cable set with IP68/NEMA 6P plugs: • 5 m (16.4 ft) – PG 13.5 ²⁾ • 5 m (16.4 ft) – M20 • 10 m (32.8 ft) – PG 13.5 ²⁾ • 10 m (32.8 ft) – M20 • 20 m (65.6 ft) – PG 13.5 ²⁾ • 20 m (65.6 ft) – M20 • 30 m (98.4 ft) – PG 13.5 ²⁾ • 30 m (98.4 ft) – M20	FDK:087L4108 A5E00862482 FDK:087L4109 A5E00862487 FDK:087L4110 A5E00862492 FDK:087L4111 A5E00862497	
Cable set with pre-mounted conduit adaptor • 10 m • 20 m	A5E33400834 A5E33400836	

¹⁾ Not applicable to custody transfer (CT) verified systems without re-verification

²⁾ For sensors produced before October 2007

MAG 8000 (7ME6880) grounding ring service kit, consisting of 2 pcs. grounding rings (AISI 304/1.4301), screws and gaskets.

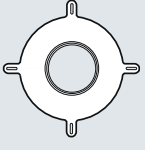
Dimension	Article No.	
Drilled pattern flanges (7 bar)		
DN 50 2"	A5E03082907	
DN 65 2½"	A5E03082908	
DN 80 3"	A5E03082909	
DN 100 4"	A5E03082910	
DN 125 5"	A5E03082911	
DN 150 6"	A5E32877967	
DN 200 8"	A5E03082913	
DN 250 10"	A5E03082914	
DN 300 12"	A5E03082915	
DN 350 14"	A5E03082916	
DN 400 16"	A5E03082917	
DN 450 18"	A5E03082918	
DN 500 20"	A5E03082919	
DN 600 24"	A5E03082920	
AS 2191 table E flanges		
DN 25 1"	A5E33474999	
DN 40 1½"	A5E33475000	
DN 125 5"	A5E33475006	
AS 4087 PN 16 flanges		
DN 50 2"	A5E33475001	
DN 65 2½"	A5E33475002	
DN 80 3"	A5E33475003	
DN 100 4"	A5E33475004	
DN 150 6"	A5E33475007	
DN 200 8"	A5E33475008	
DN 250 10"	A5E33475009	
DN 300 12"	A5E33475010	
DN 350 14"	A5E33475011	
DN 400 16"	A5E33475012	
DN 450 18"	A5E34240921	
DN 500 20"	A5E33475013	
DN 600 24"	A5E33475014	
DN 700 28"	A5E33414889	
DN 800 32"	A5E33414890	
DN 900 36"	A5E33414891	
DN 1000 40"	A5E33414892	
DN 1200 48"	A5E33414893	

Operating instructions for SITRANS FM MAG 8000

Description	Article No.
• English	A5E03071515
• German	A5E00740986

All literature is available to download for free, in a range of languages, at <http://www.siemens.com/processinstrumentation/documentation>

Operating instructions for MAG 8000 3G/UMTS communication module

Description	Article No.
• English	A5E03644134