



CMT Multilevel System

[More Info](#) | [Instructions](#) | [Get Quote](#)

Assembly Manual

February 14 2020

Solinst[®]



Table of Contents

CMT Multilevel System Pre-installation Requirements..... 1

- a) Minimum information required for effective design of the CMT Multilevel System..... 1
- b) Ensure that these additional items are available on site during installation..... 1

Introduction..... 2

Preparation 2

Assembling Standard CMT Multilevel Systems..... 3

- Marking and Cutting the Tubing4**
 - Step 1) Uncoil Tubing 4
 - Step 2) Indicate Ground Surface on Tubing..... 4
 - Step 3) Locate Channel 1 Identifier 5
 - Step 4) Mark Monitoring Port 1 5
 - Step 5) Mark Port 1 for Port Cutting Guide 6
 - Step 6) Mark all Ports and Cut Tubing at Deepest Port 6
 - Step 7) Complete Design 6
- Cutting the Outer Ports and Vent Holes7**
 - Step 8) Install the Port Cutting Guide 7
 - Step 9) Use Cutting Bolts to Cut Holes 7
 - Step 10) Cut Panel Between Upper Two Port Holes..... 8
 - Step 11) Insert Expansion Plug 9
 - Step 12) Install the Well Screen 10
 - Installing Oetiker Clamps 10
 - Step 13) Line-up Port Cutting Guide 11
 - Step 14) Create Port 2 Opening 11
 - Step 15) Finish Constructing Port 2 11
 - Step 16) Construct Ports 3 to 6 11
- Configuring the Bottom of the CMT Tubing (Zone 7)..... 12**
 - Step 17) Insert Expansion Plugs 12
 - Step 18) Attach the Guide Point Port (#105856) 12
 - Step 19) Install an Anchor 13
- Attaching Tubing Centralizers..... 13**
 - Step 20) Install Centralizers 13
- CMT Placement 14**
 - Step 21) Lower the CMT System..... 14
 - Step 22) Complete the Well Installation 14
- Attaching the Standard Wellhead (after the well has been installed)....15**
 - Step 23) Attach the Wellhead..... 15

Optional Flow Control Monitoring Assembly	16
Optional Multi-Purge Manifold Assembly	17
Monitoring Options	18
Water Level Measurement	18
Sampling Methods.....	18
Accessories.....	18
Well Completion	18
Appendix.....	19

CMT Multilevel System Pre-installation Requirements

Please complete this form to verify that proper consideration has been given to design and borehole specifications for each CMT Multilevel System to be installed. (CMT tubing 1.7" OD, Guide Point Port 1.75" OD, Guide Point Port with Anchor 3.75" OD).

a) Minimum information required for effective design of the CMT Multilevel System

Accurate borehole depth _____ Borehole angle _____
Depth to which CMT System is to be installed _____
Borehole geology _____
Drilling method _____
Casing size (minimum ID) _____
Depth to base of well casing _____
Number of monitoring zones _____
Approximate depth to static water level _____
Expected maximum pressure heads at each port location _____
Site conditions (e.g. dry field, bush, swamp, paved, etc.) _____
Any special surface requirements for completion
of installation (e.g. flush mounted, angled, etc) _____

Solinst can assist the client in the component selection for the CMT Multilevel System based on the above requested information, but final design and installation details remain the responsibility of the purchaser.

b) Ensure that these additional items are available on site during installation

- CMT Installation Hand Tools (as shown at right)
- Measuring tape
- Hacksaw
- Marking pen or wax pencil
- Adjustable wrench
- Support stand (if purchased separately)
- Model 102 or 102M Water Level Meters
- Model 103 Tag line for checking backfill depths
- At least two client representatives to supervise and assist with installation



NOTE

Optional webinar installation training is available. Contact Solinst for details.

NOTE

Always follow local health and safety guidelines. Work safely.

NOTE

Practice making one or two ports in a short section of CMT before starting out on the real thing.

Introduction

The Solinst Model 403 CMT Multilevel monitoring well system represents a revolution in multilevel groundwater monitoring. The CMT System provides the simplicity of a bundle type installation with the benefits of backfilling or sealing around a single tube.

This manual describes the above-ground assembly of CMT wells. This consists of creating intake ports in the various channels at the desired depths, installing water-tight plugs below each intake port, adding mesh screens, sealing the bottom of the tubing, and attaching low-profile borehole centralizers to the tubing. For installations in bedrock or cased 2" wells, inflatable packers can be attached to the CMT tubing to seal the borehole between the various intake ports.

Assembling CMT wells is straightforward and can be performed by either drilling contractors or environmental consultants. The wells can be assembled on site while the borehole is being drilled or off site and then transported to the job location. While the assembly of CMT wells is not difficult, it is important to follow all of the steps described in this manual. It is especially important when creating the monitoring ports to avoid cutting into one of the adjacent channels. Doing so creates a hydraulic connection between the two channels that cannot be repaired. Please read this manual carefully before assembling your first CMT well. In addition we suggest that you practice making one or two ports in a short section of CMT tubing before starting out on the real thing.

If needed, Solinst can provide one-on-one installation training in a number of different ways, such as a classroom setting, outdoors, or a webinar tutorial and presentation. Contact Solinst for details.

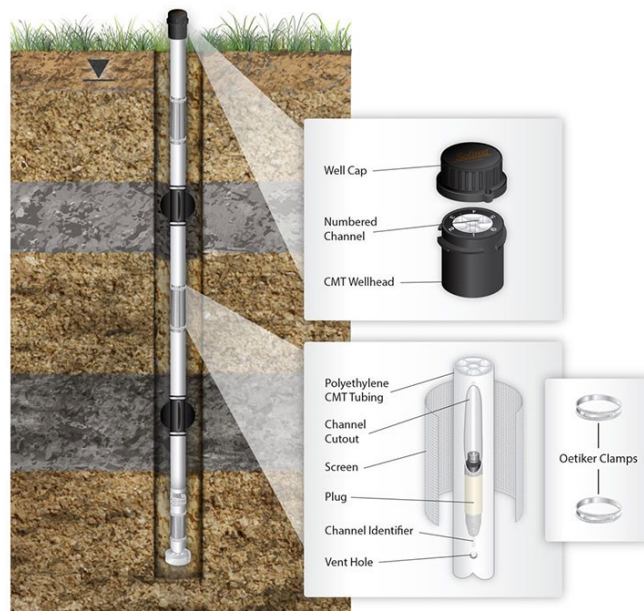

Figure 1

Preparation

Before making any ports in the CMT tubing, make a sketch of the desired well design. Show the depths of the desired monitoring zones and centralizers (if used) in feet/meters below ground surface. Also, show the depths of the desired lifts

NOTE

Avoid using "single lifts" of grout greater than 50 ft in the unsaturated zone.

of sand and bentonite graphically on the figure. This will come in handy when you are measuring the depths of the backfill materials when you are building the well. If you are building a CMT well where alternating layers of sand and bentonite backfill are added from the surface, try to allow for two feet or more of sand above and below the monitoring ports to ensure that the bentonite does not cover the monitoring ports.

Remember to allow sufficient wellhead access when you install the protective cover over the well. Plan on using a large well cover (greater than 4" diameter is recommended) to allow plenty of room to access the wellhead. A diagram showing suggested dimensions of the wellhead and protective cover is shown in Figure 2 for flushmount and above ground completions.

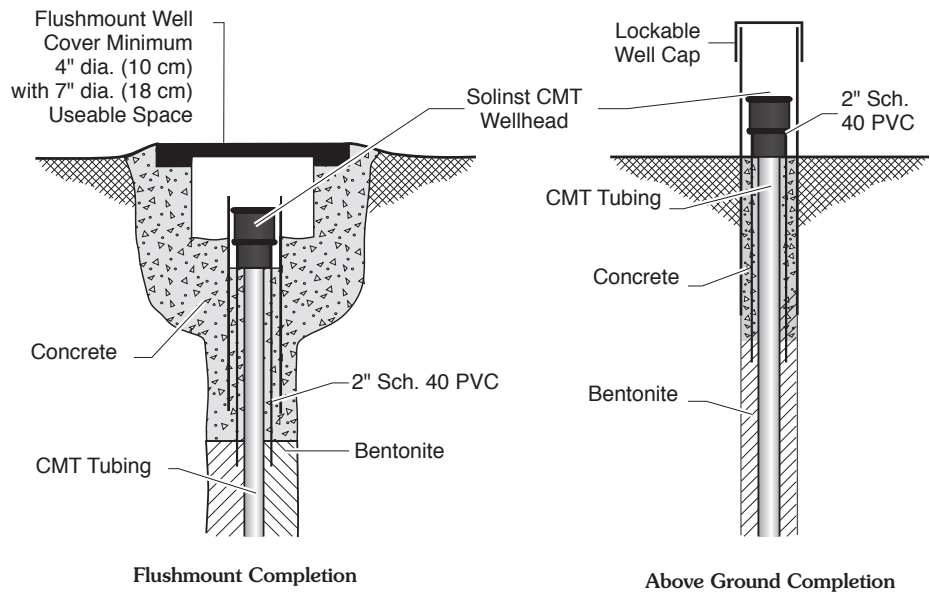

Figure 2

Assembling Standard CMT Multilevel Systems

Table 1 shows the design of a hypothetical CMT Multilevel System designated well "ML-1." Each channel in this well can be used for both collecting a groundwater sample (with either a peristaltic pump, inertial pump or micro double valve pump) and measuring the depth to water. Each channel therefore functions both as a sampling port and an observation port.

Monitored Zone	Channel Number	Depth to Center of Port (from ground surface)
1	1	23 ft (7.0 m)
2	2	34 ft (10.4 m)
3	3	48 ft (14.6 m)
4	4	55 ft (16.8 m)
5	5	69 ft (21.0 m)
6	6	77 ft (23.5 m)
7	7	92 ft (28.0 m)

Table 1
Hypothetical Design for a Standard CMT Well (Well ML-1)

NOTE

A 12.5 inch-pounds torqued port plug is designed to hold 20 psi (50 ft) of head differential.

! NOTE

Newly uncoiled CMT tubing has a memory which can make it difficult to lay out straight. Sand bags help to hold down the ends of the tubing. The "memory" goes away relatively quickly, especially in warm weather. Placing the tubing on black plastic sheeting can warm the tubing, helping it straighten out more quickly.

Marking and Cutting the Tubing**Step 1) Uncoil Tubing**

Uncoil the CMT tubing on the ground or other flat surface. Stretch out a measuring tape at least as long as the depth of the well, next to the CMT tubing.



Figure 3

Step 2) Indicate Ground Surface on Tubing

Allowing for your desired wellhead stick up (2-3 feet above ground surface), place the end of the measuring tape below the length of tubing you want above ground. This is your measuring point which represents ground surface and all depths below this point use depths below ground surface.



Figure 4

! NOTE

The channel identifier on the CMT tubing is intentionally subtle to avoid being a conduit for vertical leakage.

Step 3) Locate Channel 1 Identifier

The next step is to make marks on the CMT tubing at the depths corresponding to the midpoint of the desired monitoring ports. Before you do this, you will note that there is a faint channel identifier, a low profile repetitive marking “<< CMT >>” that runs along the entire length of the CMT tubing opposite one of the outer channels. This channel identifier facilitates identification of the various internal channels anywhere along the length of the tubing. The channel that has the identifier is always Channel 1. By convention, Channel 1 corresponds to the shallowest monitoring zone. The other five outer channels are numbered clockwise from 2 through 6 as you are looking down on the completed well from above. The center channel is Channel 7 and is always the deepest monitoring zone.

Step 4) Mark Monitoring Port 1

Make a mark across Channel 1 (Figure 5) on the exterior of the CMT tubing at the depth corresponding to the center of the uppermost monitored port (23 feet below ground surface in our hypothetical example; Table 1). A wax pencil works well for this. Write “Port 1” on the CMT tubing about 6” above the mark.

! NOTE

The Channel 1 identifier is a low profile repetitive marking “<< CMT >>”.



Figure 5

! NOTE

The next series of instructions use hand tools and materials that are sharp. Use proper protective equipment. Work safely.

Step 5) Mark Port 1 for Port Cutting Guide

Next, draw a line along the Channel 1 identifier (i.e., parallel with the tubing extending approximately 6" above and 6" below the depth mark (Figure 6). You will use this line (and other similar lines drawn at the other port depths to index the Port Cutting Guide. This ensures that you cut holes only in the intended channels corresponding to the desired monitoring zones (as shown in Table 1).



Figure 6

Step 6) Mark all Ports and Cut Tubing at Deepest Port

Make similar marks at the depths corresponding to the next five monitoring zones (i.e., 34, 48, 55, 69, and 77 feet below ground surface). Make the marks identical to the ones you drew at Port 1. That is, draw the depth mark across Channel 1 and draw the longitudinal line along the Channel 1 identifier. The Port Cutting Guide has been indexed so that it always references the Channel 1 identifier when it is used to cut holes in the five other outer channels. Label these depth marks as Port 2, Port 3, etc.....about 6" above each mark. Finally, make a mark at the depth of the deepest monitoring port (i.e., the internal channel, Port 7), which is also the bottom of the well, at 92 feet. Cut the CMT tubing at this mark using a hacksaw, sharp knife, or PVC cutter.



Figure 7

Step 7) Complete Design

The design of the well has now been transferred to the CMT tubing

Cutting the Outer Ports and Vent Holes

Step 8) Install the Port Cutting Guide

Slide the Port Cutting Guide over the CMT tubing down to Port 1. Align the notch stamped “1” on the Port Cutting Guide with the line you drew along the Channel 1 identifier. Position the Port Cutting Guide so that the depth mark “+” (indicating the centre of the Port) is visible in the window in the center of the Port Cutting Guide (Figure 8). Secure the Port Cutting Guide to the CMT tubing by tightening the knurled Locking Bolts on the underside of the guide (Figure 9). Tighten the bolts, by hand only, to prevent the Port Cutting Guide from moving.

! NOTE

When using the Port Cutting Guide, ensure that the cutting bolts are located below the number 1 on the front of the Guide. The locking bolts go below the number 4 on the back of the Port Cutting Guide.



Figure 8



Figure 9

Step 9) Use Cutting Bolts to Cut Holes

Next, cut three holes, as described below into Channel 1 using the cutting bolts screwed into the Port Cutting Guide. Do not rush when screwing the cutting bolts into the Port Cutting Guide. Ensure the bolts are properly lined up with the holes in the Port Cutting Guide so that cross threading does not occur.

Start by threading a cutting bolt into one of the holes located on the same side as the window. Use the hex wrench to tighten the Cutting Bolt. Tighten the bolt a few revolutions, then loosen it one revolution. Continue doing this until the Cutting Bolt “bottoms out” (Figure 10). Remove the Cutting Bolt. There should be a plastic disk inside of the cutting bolt. If there isn't, re-insert the cutting bolt and repeat the cutting process (make sure that the knurled Locking Bolts are tight). Push out the piece of plastic from the inside of the Cutting Bolt by inserting an Allen wrench through the small hole drilled in the head of the Cutting Bolt (Figure 11). Repeat this process to cut all three holes. The two upper holes will provide the port plug access and the lowest hole is the vent hole (Figure 12).

! NOTE

For easy effective cutting, advance the cutter bolt in alternating increments of ~1.5 turns clockwise, and then 0.5 turn counter-clockwise, repeatedly.

! NOTE

If installing numerous systems, spare cutting bolts can be ordered, as they may become dull after repeated use. It is recommended to order an extra bolt per 10 ports constructed.



Figure 10



Figure 11



Figure 12

! NOTE

The two upper holes allow you to use snips to cut away a panel of plastic between the two holes, creating a 3-inch long port in Channel 1. The bottom hole is a vent hole. A vent hole is needed to allow air to escape from the channel beneath the monitoring port when the CMT tubing is inserted into the water-filled borehole during well installation.

Step 10) Cut Panel Between Upper Two Port Holes

Loosen the cutting tool and move it “down” the CMT and out of the way. Next, use the snips as shown in Figure 13 to cut out the panel of plastic between the upper two port holes. Do this carefully and keep the snips parallel to the channel side wall to avoid cutting into the walls separating Channel 1 from Channels 2 and 6. Make the opening as large as possible to facilitate the insertion of the expansion plug as described in the next step.

**Figure 13****Figure 14**



Figure 15
Standard Port Assembly (#106278)

! NOTE

The vent hole does not allow cross connection with other monitoring zones because the bottom of the channel is sealed with a water-tight plug.

! NOTE

When installing the expansion plug, temperature of the CMT should be between -15°C and 35°C. If air temperature is above 35°C, use cold water to cool down the tubing at the port before installing the expansion plug.

Step 11) Insert Expansion Plug

Insert an expansion plug through the opening (Figure 16) so that it seals Channel 1 below the monitoring port and above the vent hole. If necessary, use the torque driver to gently push the plug into place (Figure 17). Use the snips to trim the port opening if you have difficulty inserting the plug. Tighten the plug to a torque of 12.5 inch-pounds using the supplied torque driver.



Figure 16



Figure 17

NOTE

Wetting the Oetiker Clamp reduces friction, making installation easier.

Step 12) Install the Well Screen

The last step in making the Channel 1 port consists of wrapping the stainless steel mesh around the port, forming a well screen over the opening. Center the mesh over the port opening and wrap it tightly around the CMT tubing (Figure 18). Use the low profile Oetiker clamps and pliers to firmly secure the mesh to the tubing. See the section below for more details about installing Oetiker clamps. Use two clamps for each monitoring port (Figure 20). Construction of Port 1 is now finished. You are now ready to make Port number 2.

Installing Oetiker Clamps

Wrap the Oetiker clamp around the part (eg. screen, centralizer, guide point) you are clamping. Allow the first (closest) retaining hook to pass through the long slot opening. Squeeze the clamp by hand until the retaining hook catches the end of this opening. Figure 19 shows this step. Fit the 'jaw tips' of the Oetiker pliers into each of the clamp's 'tunnels'. Squeezing/closing the Oetiker pliers simultaneously draws the two tunnels together. With the two tunnels drawn together, push down on the tail of the clamp, so that the furthest retaining hook passes through the last slot. Now release the pliers so that the retaining hook catches the clamp and holds.

**Figure 18****Figure 19****Figure 20**

! NOTE

To avoid installing ports in the wrong channels start by positioning the Port Cutting Guide so that the depth mark is visible in the window, then rotate the guide so that the appropriate number (corresponding to the port number) is indexed against the line you drew earlier along the longitudinal Channel 1 identifier. This step is very important.

! NOTE

At some sites, you may decide that it is not necessary to monitor every channel. In that case, only cut ports in the desired channels.

When constructing the bottom assembly, only insert the expandable plugs into the monitored channels, leaving the other channels open so that they can fill with water as the CMT tubing is inserted into the borehole (e.g. If only three channels are monitored, only those channels should have plugs inserted at the base.) This reduces buoyancy during well installation.

Step 13) Line-up Port Cutting Guide

Slide the Port Cutting Guide down to Port 2. Position the Port Cutting Guide exactly as you did for Port 1. The depth mark should be visible in the window of the Port Cutting Guide and the longitudinal Channel 1 identifier should be indexed to the number “1” stamped on the guide (Figure 21). Now, rotate the Port Cutting Guide (without moving its position along the CMT tubing) so that the longitudinal line is now indexed to the number “2” stamped on the guide (Figure 22). This positions the Port Cutting Guide so that the cutting bolts will cut holes only into Channel 2. Secure the Port Cutting Guide using the knurled Locking Bolts as before. Cut the two port holes and one vent hole into Channel 2. Next, loosen the cutting tool and slide it down the tubing out of the way.



Figure 21

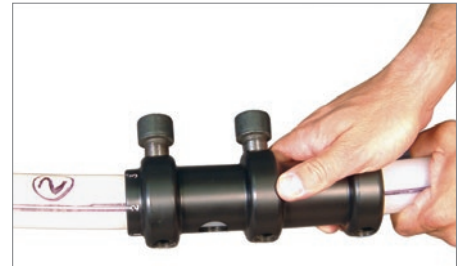

Figure 22

Step 14) Create Port 2 Opening

Snip away the panel of plastic between the upper two holes, creating an opening for Port 2.

Step 15) Finish Constructing Port 2

Next, insert an expansion plug through the opening, positioning it below the monitoring port, and tighten it to 12.5 inch-pounds as before. Finally, wrap a piece of stainless steel mesh around the opening and secure it with two stainless steel clamps. You have now finished constructing Port 2.

Step 16) Construct Ports 3 to 6

Continue the steps described above for Ports 3 through 6.

Configuring the Bottom of the CMT Tubing (Zone 7)

NOTE

Port plugs are tightened to a torque of 12.5 inch-pounds. Plugs in the base, or bottom, of the CMT should be torqued sequentially and incrementally to ensure even expansion.

Step 17) Insert Expansion Plugs

At the bottom of the CMT tubing, insert an expansion plug into each of the six channels. (Figure 23) Tighten each to a torque of 12.5 inch-pounds using the torque driver.

Step 18) Attach the Guide Point Port (#105856)

Slide the Guide Point Port Assembly (Figure 24) over the end of the CMT tubing and secure it to the tubing with the gear clamp (Figure 25). Use a torque tool and drive socket extension to tighten the gear clamp to a torque of 12.5 inch-pounds. The end of the Guide Point Port Assembly is tapered to prevent the bottom of the CMT tubing from getting snagged on a rock ledge or casing joints as it is being inserted into a borehole. The end of the Guide Point Port Assembly also has threading (3/8" – 16 UNC) to connect a weight, if desired. With the gear clamp torqued to 12.5 inch-pounds, the Guide Point Port Assembly can support up to 20 lbs of additional weight (optional).



Figure 23



Figure 24



Figure 25

Step 19) Install an Anchor

If desired, an anchor (3.75" diameter) can be attached to the Guide Point Port using a hex bolt (Figure 26). An anchor is used during installations where it is helpful to secure the bottom of the CMT to keep it from moving during well construction. Once the tubing has been inserted, use sand placed on top of the anchor to secure the well. This will prevent it from being pulled up as drive casing or augers are withdrawn from the borehole. Holes have been drilled in the anchor to allow water in the borehole to pass through the anchor when the CMT well is inserted.



Figure 26

Attaching Tubing Centralizers**Step 20) Install Centralizers**

Place the centralizers over the CMT tubing at the desired depths. Centralizers are generally placed along the CMT tubing at intervals ranging from every 5 to every 15 feet. Attach the centralizers securely to the CMT tubing using two stainless steel clamps (Figure 27).

The CMT well is now ready to be inserted into the borehole.



Figure 27
5.5" OD Centralizer (#113907)

! NOTE

Solinst has developed special tubing centralizers that ensure that the tubing is centered in the borehole during well construction. The fins on the centralizers are low-profile to prevent them from obstructing the tremie tube, or sand and bentonite pellets poured from the surface. Centralizers are available as 5.5" OD, 4.4" OD, and 3.5" OD.

CMT Placement

Step 21) Lower the CMT System

! NOTE

The Solinst Tag Line, (Model 103), is recommended for accurate sand and bentonite placement.



Figure 28

Lower the assembled CMT System into the borehole slowly.

If buoyancy is a problem, wait, as the channels below water level will slowly fill and allow the system to be lowered further. To speed this process along, pour or pump clean water into the vent holes.

When the required depth is reached, suspend the system with the System Support Clamp (Figure 29) to prevent it from moving during well construction.

! NOTE

Once the backfilling operation is complete, the System Support Clamp is removed and can be reused for the next installation.



Figure 29
CMT System Support Clamp (#105603)

! NOTE

Avoid using "single lifts" of grout greater than 50 ft in the unsaturated zone.

Step 22) Complete the Well Installation

Complete the installation by carefully pouring or using a tremie to place sand and bentonite at appropriate levels to seal the borehole annulus.

Attaching the Standard Wellhead (after the well has been installed)**Step 23) Attach the Wellhead**

After the well has been built, cut the CMT tubing to the final elevation. You may choose to finish your CMT installation above ground surface. If so, you can leave the CMT stick-up as is and install the standard wellhead register or “house” the CMT inside a cut length of 2" dia. PVC riser pipe (not supplied).

If housing in a PVC pipe, first slide the PVC pipe over the CMT stick-up, and push below the final elevation of the CMT. Slide the wellhead base over the tubing and onto the PVC pipe. The wellhead base provides a tight friction fit on the PVC pipe.

Slide the wellhead register flush with the end of the CMT tubing. Align the stamped number one on the register with the Channel 1 identifier marking on the outside of the tubing. Secure the wellhead to the CMT tubing by tightening the hex screw on the side of the wellhead register using a 1/8" Allen Key. Bring the PVC pipe up so the register seats in the wellhead base (Figure 30). Grout or cement the PVC pipe in place.

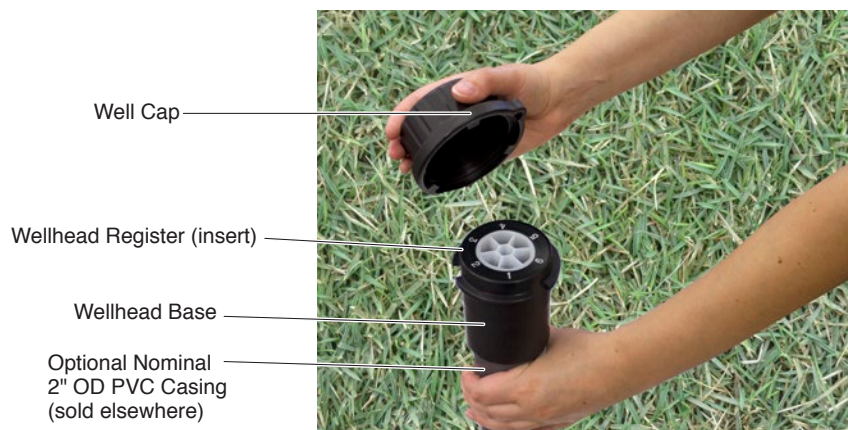

Figure 30
7CH Standard Wellhead (#110525)

Optional Flow Control Monitoring Assembly

Under flowing artesian conditions or for vapor sampling, the CMT can be fitted with a flow through seal assembly (Figure 31) to allow the user to collect a sample, measure hydraulic or pneumatic pressure, and prevent uncontrolled flow from the well.



Figure 31
Flow Through Seal Assembly (#106003)

The flow through seal assembly is tightened using a 11/32" (9 mm) wrench. Once tightened, press down on the black ring while pulling up to remove the red plug. Then push the 1/4"OD tubing into the fitting, which creates a leak proof seal.



Figure 32

! NOTE

Airflow adjustments are made using the valves on the top of the head assembly of the manifold. A clockwise turn reduces air supply, counter-clockwise increases the air supply. If a valve is all the way down, it is in the off position. Valves can be adjusted by hand, but if they are too tight, a slot head screwdriver can be used.

Optional Multi-Purge Manifold Assembly

To purge and sample up to 4 Micro Double Valve Pumps, at a single location, a Multi-Purge Manifold Assembly is available.

1. Mount the Multi-Purge Manifold over the well installation.
2. Thread the pumps down through the collar opening in the Multi-Purge Manifold below the head assembly.
3. Connect each individual pump manifold to the appropriately numbered Multi-Purge Manifold connection by pushing the male LL10 connector (on the pump manifold) into the brass quick connect fitting (on the assembly) while pulling back the brass sleeve on the fitting.
4. Connect the compressed gas source/controller to the Multi-Purge connection at the top of the head assembly, using the same method as described in step 3.
5. Open and adjust valves on the head assembly of the Multi-Purge Manifold for those pumps that require purging/sampling. Operate control box according to the instructions provided.



Figure 33

Monitoring Options

Water levels and samples can be accurately obtained using the following high quality Solinst instruments:

Water Level Measurement

Model 102 Water Level Meter

The narrow cable Model 102 Water Level Meter and 102M Mini Water Level Meter with a 4 mm (0.157") dia. P4 Probe can be used to monitor water levels in open tubes. The cable is accurately laser marked every mm or 1/100 ft.



Well Completion

Model 103 Tag Line

The Tag Line is ideal to aid accurate placement of sand and bentonite during borehole completion.

The durable cable is laser marked every 5 cm or 1/4 foot.



Sampling Methods

Depending on the depth to water at your site, and your sampling protocol, Solinst offers various sampling options.

Model 410 Peristaltic Pump

Ideal for sample retrieval from shallow water levels less than 9 m (30 ft.).



Mini Inertial Pump

This Mechanical pump uses 1/4" LDPE tubing. Typical flow rates of 50 to 250 ml/min. Suitable for use to depths of approximately 45 m (150 ft.). If the water level on your site is deeper than 15 m (50 ft.), PTFE tubing is recommended.



Model 408M (3/8" Dia.) Micro Double Valve Pump

The Small and flexible design makes this gas drive pump ideal for delivering high quality samples, in combination with the Model 464 Electronic Control Unit. Flow rates of 20 to 150 mL/min make the 408M suitable for low flow sampling applications. Constructed of stainless steel and LDPE for lengths less than 15 m (50 ft.) and PTFE tubing for any depths up to 75 m (250 ft.) applications. This is the only viable option in CMT wells with depth to water over 45 m (150 ft.).



Accessories

Multi-Purge Manifold

A multi-purge manifold can be considered for purging multiple CMT channels simultaneously using Micro Double Valve Pumps in each channel.

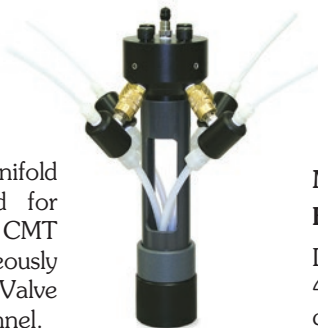

Model 464 Electronic Control Unit

Durable and easy to operate with the 408M by using built-in presets, or customized saved settings.



Vapor Monitoring & Wellhead Seal Assembly

Channel seal assemblies are available to seal the CMT channels in case of flowing artesian conditions, or for vapor monitoring. If desired, a 3-way valve can be attached to the seal assembly directing vapor to a pressure gauge connected at one end of the valve and a sample vessel at the other.



CMT Specifications		
	7-Channel	3-Channel
Material	*MDPE	*MDPE
Tubing outside diameter	1.7" (43 mm)	1.1" (28 mm)
Channel diameter	6 - Outer pie channels: nominal 0.4" (10 mm) 1 - Center hex channel: nominal 3/8" (9.5 mm)	3 - Hex channels: nominal 3/8" (9.5 mm)
Channel volume	40 mL/ft 30 mL/ft (center)	30 mL/ft
Installation options**	Sand & bentonite backfill Natural formation collapse	Bentonite & sand cartridges Sand & bentonite backfill Natural formation collapse
Coil lengths*** (Coil 4 ft dia.)	100 ft (30 m), 200 ft (60 m) & 300 ft (90 m)	100 ft (30 m), 200 ft (60 m), & 500 ft (150 m)
Tubing temperature during installation	-15°C to +35°C ****	
Port plug temperature during installation	+15°C to +35°C	
Pressure differential (water levels)	12.5 inch-pounds torqued port plugs are designed to hold 20 psi (50 ft) of head differential.	

Notes	
	* Tubing is MDPE; proprietary mix of HDPE and LDPE products.
	** Avoid using 'single lifts' of grout, greater than 50 ft in the unsaturated zone.
	*** Each CMT coil measures 1 to 2 ft longer than stated.
	**** If air temperature is above +35°C, use cold water to cool down the tubing at the port before installing the port plug.

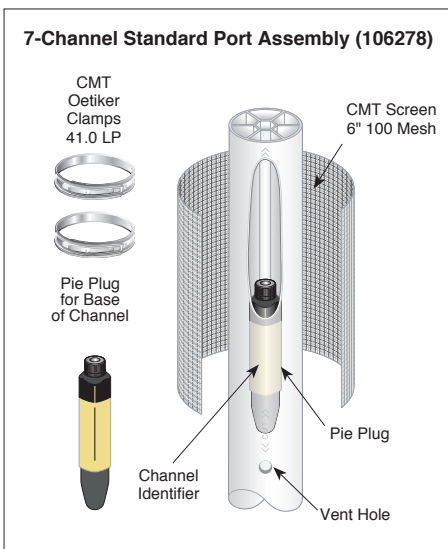

Note: Port plugs are tightened to a torque of 12.5 inch-pounds. Plugs in the base, or bottom, of the CMT should be torqued sequentially and incrementally to ensure even expansion.

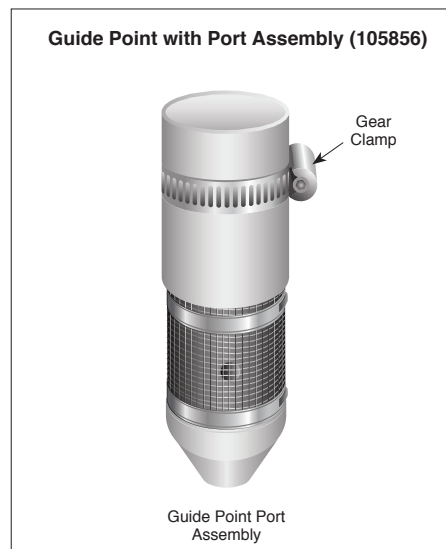

Note: Gear clamp is tightened to a torque of 12.5 inch-pounds, so guide point can support up to 20 lbs of additional weight (optional).

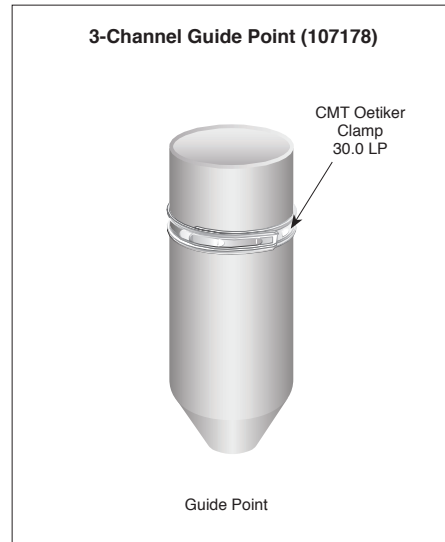
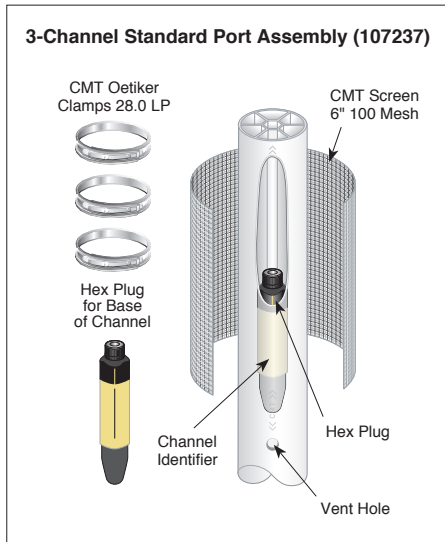

Note: Port plugs are tightened to a torque of 12.5 inch-pounds.

Hand Tools for CMT System Assembly



Terms and Conditions
for Waterloo or CMT® System Multilevel Installation Training
An Understanding of Responsibility

Solinst Canada Ltd. (Solinst) offers installation training only, which includes providing verbal and 'by example' instruction of proper methods of assembling Waterloo or CMT Multilevel Systems. Actual installation of a Solinst Multilevel System is the sole responsibility of the Customer. Solinst cannot offer guidance, nor recommend the location of a monitoring zone, nor advise on the backfilling of the System to achieve the monitoring zones your site requires.

Based on the information that you provide, Solinst may assist with determining sufficient quantities of components to construct your Multilevel System(s), however Solinst assumes no responsibility for the chemical and physical compatibility of materials, initial design or on- site layout design, in-field design changes, or the condition of the borehole(s).

All equipment received by the client for use in their installations must be inspected upon receipt, and any deficiencies noted and reported to Solinst immediately.

Solinst, at its sole discretion, reserves the right to assess the cause and liability of any System fault or equipment failure at the time of receipt, during assembly, or following installation. If the defect is determined to be caused by inadequate materials or workmanship, excluding actual installation procedures – which are the Customer's responsibility – Solinst will, at its own discretion, replace or refund the cost of the failed component. Solinst is not liable for any contingent costs which may arise from the installation for any reason including the loss of use of any part of the System(s) or borehole(s).

The undersigned understands and accepts the above terms and conditions:

Company: _____ Signature: _____

Name: _____ Date: _____

