

DigitalFlow™ GC868

Panametrics Gas Clamp-On Ultrasonic Flowmeter Programming Manual (1-Channel)



DigitalFlow™ GC868

Panametrics Gas Clamp-On Ultrasonic Flowmeter

Programming Manual (1-Channel)

BH014C31 EN G
May 2023

panametrics.com

Copyright 2023 Baker Hughes company.

This material contains one or more registered trademarks of Baker Hughes Company and its subsidiaries in one or more countries. All third-party product and company names are trademarks of their respective holders.

[no content intended for this page]

Warranty

Each instrument manufactured by Panametrics is warranted to be free from defects in material and workmanship. Liability under this warranty is limited to restoring the instrument to normal operation or replacing the instrument, at the sole discretion of Panametrics. Fuses and batteries are specifically excluded from any liability. This warranty is effective from the date of delivery to the original purchaser. If Panametrics determines that the equipment was defective, the warranty period is:

- one year for general electronic failures of the instrument
- one year for mechanical failures of the sensor

If Panametrics determines that the equipment was damaged by misuse, improper installation, the use of unauthorized replacement parts, or operating conditions outside the guidelines specified by Panametrics, the repairs are not covered under this warranty.

The warranties set forth herein are exclusive and are in lieu of all other warranties whether statutory, express or implied (including warranties of merchantability and fitness for a particular purpose, and warranties arising from course of dealing or usage or trade).

Return Policy

If a Panametrics instrument malfunctions within the warranty period, the following procedure must be completed:

1. Notify Panametrics, giving full details of the problem, and provide the model number and serial number of the instrument. If the nature of the problem indicates the need for factory service, Panametrics will issue a RETURN AUTHORIZATION number (RA), and shipping instructions for the return of the instrument to a service center will be provided.
2. If Panametrics instructs you to send your instrument to a service center, it must be shipped prepaid to the authorized repair station indicated in the shipping instructions.
3. Upon receipt, Panametrics will evaluate the instrument to determine the cause of the malfunction.

Then, one of the following courses of action will then be taken:

- If the damage is covered under the terms of the warranty, the instrument will be repaired at no cost to the owner and returned.
- If Panametrics determines that the damage is not covered under the terms of the warranty, or if the warranty has expired, an estimate for the cost of the repairs at standard rates will be provided. Upon receipt of the owner's approval to proceed, the instrument will be repaired and returned.

[no content intended for this page]

Table of Contents

Chapter 1. Programming Site Data

1.1	Introduction	1-1
1.2	Using the Keypad	1-2
1.3	Obtaining On-line Help	1-6
1.4	Using the Console Control Keys	1-7
	1.4.1 Audio Alarm Volume	1-7
	1.4.2 Stopwatch Totalizer	1-7
	1.4.3 Display Brightness	1-7
	1.4.4 Display Contrast	1-7
1.5	The User Program	1-7
	1.5.1 Entering Programming Mode	1-8
1.6	Activating the Channel	1-8
	1.6.1 Procedure Options	1-9
1.7	Entering System Data	1-9
	1.7.1 Entering System Units	1-9
	1.7.2 Entering Volumetric Data	1-9
	1.7.3 Entering Totalizer Data	1-10
	1.7.4 Mass Flow (static)?	1-10
	1.7.4.1 Procedure Options	1-10
1.8	Entering Pipe Data	1-10
	1.8.1 Special Transducers	1-10
	1.8.2 Wedge Temperature	1-11
	1.8.3 Pipe Material	1-11
	1.8.4 Pipe OD	1-11
	1.8.5 Pipe Wall	1-12
	1.8.6 Fluid Type	1-12
	1.8.7 Reynolds Correction	1-12
	1.8.8 Calibration Factor	1-12
	1.8.9 Number of Traverses	1-12
	1.8.10 Transducer Spacing	1-12
	1.8.10.1 Procedure Options	1-12
1.9	Setting Up Inputs/Outputs	1-12
	1.9.1 Selecting Error Handling	1-13
	1.9.2 Setting Up Analog Outputs	1-13
	1.9.3 Option Card Alarms	1-14
	1.9.4 Setting Up the Totalizer/Frequency Outputs	1-14
	1.9.4.1 Programming a Frequency Output	1-14
	1.9.4.2 Programming a Totalizer Output	1-15
	1.9.5 Setting up the Analog Inputs	1-15
	1.9.6 Setting up RTD Inputs	1-16
	1.9.7 Entering the Zero Cutoff	1-16
	1.9.8 Setting Up Temperature and Pressure Inputs	1-16
	1.9.8.1 Entering the Temperature Input	1-16
	1.9.8.2 Entering the Pressure Input	1-17
	1.9.8.3 Procedure Options	1-17
1.10	Entering Setup Data	1-18
	1.10.1 Setting Signal Limits	1-18
	1.10.2 Setting Response Time	1-22
	1.10.3 Initializing the System	1-22
	1.10.4 Setting Advanced Parameters	1-22
	1.10.4.1 Static Density	1-22
	1.10.4.2 Setting the A Value	1-23
	1.10.4.3 Setting Skan/Measure Parameters	1-23
	1.10.4.4 Entering Multiple K Factors	1-24

1.10.4.5	Programming a Gas Compressibility Table	1-24
1.10.4.6	Setting Correlation Parameters	1-25
1.10.4.7	Setting Skan Parameters	1-25
1.10.4.8	Synchronizing Meter Transmissions	1-25
1.10.4.9	Procedure Options	1-25
1.11	Setting the Clock	1-26
1.11.1	Setting the Date	1-26
1.11.2	Setting the Time	1-26
1.11.2.1	Procedure Options	1-26
1.12	Setting Up Serial Communications	1-26
1.12.1	Entering MODBUS Data	1-27
1.12.2	MODBUS/TCP Parameters	1-27
1.12.2.1	Procedure Options	1-28
1.12.3	MODBUS Register Map	1-28
1.13	Saving Site Data	1-29
1.14	Recalling a Site	1-30
1.15	Activating Security	1-30
1.15.1	Procedure Options	1-31

Chapter 2. Displaying Data

2.1	Introduction	2-1
2.2	The BIG Submenu	2-1
2.3	The DUAL Submenu	2-2
2.4	The GRAPH Submenu	2-3
2.4.1	Setting Up the GRAPH Format	2-3
2.4.2	Using the GRAPH Format	2-3
2.5	The LOG Submenu	2-4
2.5.1	Entering the LOG Submenu	2-4
2.5.2	Numeric Format	2-5
2.5.3	Graphical Format	2-6
2.6	Displaying the Transducer Signal	2-7
2.7	Setting the LCD Backlight	2-10
2.8	Activating Sleep Mode	2-10

Chapter 3. Logging Data

3.1	Introduction	3-1
3.2	Creating a Standard Log	3-2
3.2.1	Log Type	3-3
3.2.2	STARTTIME Prompt	3-3
3.2.3	START DATE Prompt	3-3
3.2.4	END TIME Prompt	3-3
3.2.5	END DATE Prompt	3-4
3.2.6	DURATION Prompt	3-4
3.2.7	LOG TIME Prompt	3-4
3.2.8	TIME INCREMENT Prompt	3-4
3.2.8.1	Procedure Options	3-4
3.3	Checking the Memory	3-5
3.4	Stopping a Log	3-5
3.4.1	Procedure Options	3-6
3.5	Creating an ERROR Log	3-6
3.5.1	Log Type	3-7
3.5.2	STARTTIME Prompt	3-7
3.5.3	START DATE Prompt	3-7
3.5.3.1	Procedure Options	3-7

Chapter 4. Printing Data

4.1	Introduction	4-1
-----	--------------------	-----

- 4.2 Print Live Data 4-1
 - 4.2.1 Numeric Format 4-2
 - 4.2.2 Graphical Format 4-3
- 4.3 Printing Logs 4-4
 - 4.3.1 Numeric Format 4-5
 - 4.3.2 Graphical Format 4-5
- 4.4 Print Site File 4-6
- 4.5 Stop Printing 4-7
- 4.6 Setting Up a Printer 4-7
- 4.7 Printing Signal Array Data 4-8
- 4.8 Printing RTD Data 4-9

Chapter 5. Clearing Data

- 5.1 Introduction 5-1
- 5.2 Reset Totals 5-1
 - 5.2.1 Procedure Options 5-1
- 5.3 Deleting Site Files 5-2
 - 5.3.1 Procedure Options 5-2
- 5.4 Deleting Log Files 5-2
 - 5.4.1 Procedure Options 5-2

Chapter 6. Serial Communications

- 6.1 Introduction 6-1
- 6.2 Wiring the RS232 Interface 6-1
- 6.3 Checking the GC868 Baud Rate 6-2
- 6.4 Setting Up the Terminal Software and Transferring Data 6-2
 - 6.4.1 Windows 9X/NT Systems 6-3
- 6.5 The Optional RS485 Serial Interface 6-3
 - 6.5.1 Interface Converter Mounting 6-4
 - 6.5.2 Point-To-Point Wiring 6-4
 - 6.5.3 Multi-Point Wiring 6-5
 - 6.5.3.1 Reconfiguring a Serial Interface Converter 6-5
 - 6.5.3.2 Wiring the System 6-6
- 6.6 Setting Up an Ethernet Connection 6-7
- 6.7 Setting Up a MODBUS/TCP Connection 6-7

Appendix A. Menu Maps

Appendix B. Data Records

- B.1 Option Cards Installed B-1
- B.2 Initial Setup Data B-2

Appendix C. Programming with PanaView

- C.1 Introduction C-1
- C.2 Wiring the RS232 Interface C-1
- C.3 Setting Up the Communications Port C-1
 - C.3.1 Setting up Ethernet Communications C-2
- C.4 Adding the GC868 C-4
- C.5 Editing Meter Properties C-5
 - C.5.1 Setting the Meter Clock C-7
 - C.5.2 Reading Transducer Signals C-8
 - C.5.3 Plotting Transducer Signals C-8
 - C.5.4 Saving Transducer Signals C-9
 - C.5.5 Clearing Totalizers C-9
 - C.5.6 Handling Site Files C-9
 - C.5.6.1 Saving an Existing Site to the Meter C-10
 - C.5.6.2 Saving a New Site to the Meter C-10
 - C.5.6.3 Saving a Site to the PC C-10
 - C.5.6.4 Clearing a Site from the Meter C-11

C.5.6.5 Saving a Site in Text Form	C-11
C.6 Changing Meter Settings	C-12
Appendix D. Foundation Fieldbus Communications	
D.1 Optional Measurements	D-1
D.2 Configuration Utility Setup	D-2
D.3 Selecting the Desired Measurements	D-2
D.4 Selecting Units for AI Blocks	D-4
D.5 Resetting Instrument Totalizers	D-5
D.6 Function Block Application	D-6

Chapter 1. Programming Site Data.

Introduction.....	1-1
Using the Keypad	1-2
Obtaining On-line Help.....	1-6
Using the Console Control Keys.....	1-7
The User Program	1-8
Activating the Channel.....	1-8
Entering System Data	1-9
Entering Pipe Data.....	1-10
Setting Up Inputs/Outputs.....	1-12
Entering Setup Data	1-18
Setting the Clock.....	1-26
Saving Site Data.....	1-29
Recalling a Site.....	1-30
Activating Security.....	1-30

1.1 Introduction

The Model GC868 flowmeter cannot provide accurate flow rate measurements until the instrument has been properly installed and the basic system and pipe parameters have been programmed into the meter. See the *Startup Guide* for detailed instructions on performing these tasks. After completing the installation and initial setup, use this chapter to program the Model GC868's advanced features.

Ten submenus within the *User Program* provide access to the various programmable features of the Model GC868. Step-by-step programming instructions are presented in this chapter. Refer to the appropriate section for a discussion of the following *User Program* submenus:

- **ACTIV** - select the desired measurement method
- **SYSTEM** - enter the system data
- **PIPE** - enter the pipe parameters
- **I/O** - set up the inputs and outputs
- **SETUP** - set the signal limits and response times
- **CLOCK** - set the time and date
- **COMM** - set the serial port parameters
- **SAVE** - save site files
- **RECALL** - recall stored site files
- **SECUR** - enter a passcode

As an aid in following the programming instructions, a complete menu map of the *User Program* is included in Appendix A, *Menu Maps*.

Note: *In the menu map drawings, plain text represents prompt area messages and boxed text represents option bar choices. Fx represents a function key to select an option bar choice.*

1.2 Using the Keypad

The Model GC868 keypad contains 39 keys, that are labeled with their primary (unshifted) functions. In addition, pressing the red **[SHIFT]** key will access the secondary functions assigned to most of the keys.

The complete keypad is illustrated in Figure 1-1 below and a detailed description of both the unshifted and shifted functions for each of the 39 keys is listed in Table 1-1 on page 1-3.

Note: Only the **[SHIFT]** key and the eight **[Fx]** keys have no shifted function.

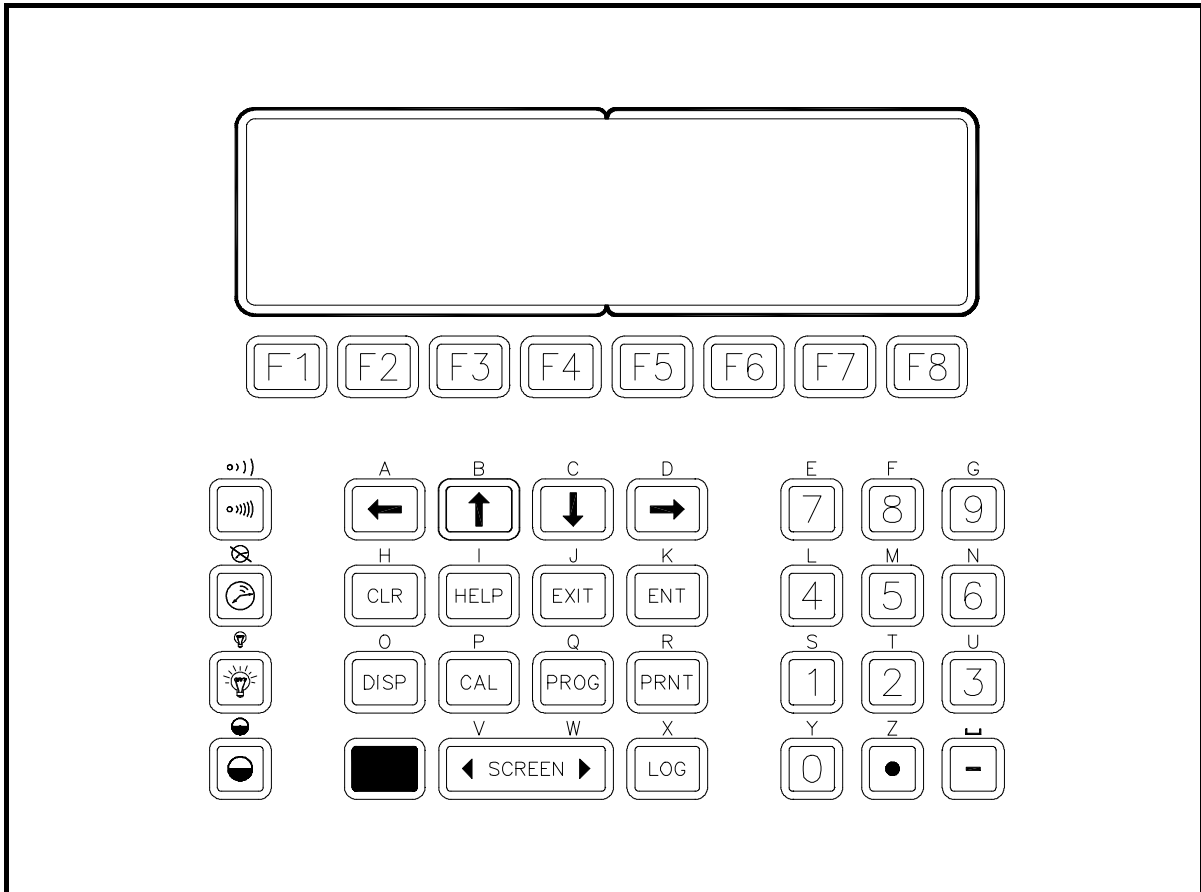

Figure 1-1: The Model GC868 Keypad

Note: Although the keypad is essentially the same, the front panel layout of meters supplied in one of the optional enclosures is different. See Appendix C, Optional Enclosures, of the Startup Guide for a picture of the applicable front panel.

Table 1-1: Model GC868 Key Functions















Key	Unshifted Function	Shifted Function
	Software Function Keys - press to select the functions displayed directly above them in the option bar. These keys apply only to the left pane of the display screen.	None
		
		
		
	Software Function Keys - press to select the functions displayed directly above them in the option bar. These keys apply only to the right pane of the display screen.	None
		
		
		
	Shift Key - use this red key to access the shifted function of the other keys. One press shifts the next keystroke only, while two presses locks the keypad in shifted mode. A third press releases the shift function.	None
	Arrow Keys - in measurement mode, use to scroll through function choices on the option bar. In programming mode, use to scroll through menu choices. The [←] also acts as a backspace key in programming mode.	Use to enter the letters A, B, C and D, respectively.
		
		
		
	Program Key - press to enter the <i>User Program</i> . See page 1-8 for details.	Use to enter the letter Q.
	Display Key - use to display data in a variety of numeric and graphic formatting options. See page 2-2 for details.	Use to enter the letter O.

Table 1-1: Model GC868 Key Functions

















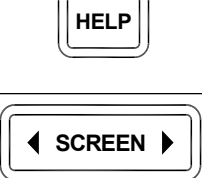





Key	Unshifted Function	Shifted Function
	Log Key - use to set up logs. See page 3-1 for details.	Use to enter the letter X.
	Print Key - use to print live measurements, log files and signal arrays. See page 4-1 for details.	Use to enter the letter R.
	Clear Key - use to reset totals and to delete site and log files from the Model GC868 memory. See page 5-1 for details.	Use to enter the letter H.
	Calibration Key - use to calibrate the analog inputs and outputs and to test the alarm relays and the totalizer/frequency outputs. See Chapter 1, <i>Calibration</i> , of the <i>Service Manual</i> for details.	Use to enter the letter P.
	Exit Key - use to move up one level in the user program or to exit the user program. See page 1-8 for details.	Use to enter the letter J.
	Enter Key - use to confirm the most recent input information.	Use to enter the letter K.
	Help Key - use to access the Model GC868's context-sensitive on-line help system. See the next section for details.	Use to enter the letter I.
	Screen Key - press the left side to select the left display pane or press the right side to select the right display pane.	Press the left side to enter the letter V or press the right side to enter the letter W.
	Decimal Point Key - press to enter a decimal point during numeric entry.	Use to enter the letter Z.
	Minus Key - use to enter a minus sign or a dash.	Use to enter a space character.
	Zero Key - use to enter the number 0.	Use to enter the letter Y.
	One Key - use to enter the number 1.	Use to enter the letter S.
	Two Key - use to enter the number 2.	Use to enter the letter T.
	Three Key - use to enter the number 3.	Use to enter the letter U.
	Four Key - use to enter the number 4.	Use to enter the letter L.

Table 1-1: Model GC868 Key Functions

Key	Unshifted Function	Shifted Function
	Five Key - use to enter the number 5.	Use to enter the letter M.
	Six Key - use to enter the number 6.	Use to enter the letter N.
	Seven Key - use to enter the number 7.	Use to enter the letter E.
	Eight Key - use to enter the number 8.	Use to enter the letter F.
	Nine Key - use to enter the number 9.	Use to enter the letter G.
	Audio Level Key - press to increase the audio alarm volume.	Press to decrease the audio alarm volume.
	Stopwatch Timer Key - press to turn the stopwatch timer on.	Press to turn the stopwatch timer off.
	Backlight Key - press to turn the display backlight on or to increase its brightness.	Press to turn the display backlight off or to decrease its brightness.
	Contrast Key - press to increase the contrast of the display screen.	Press to decrease the contrast of the display screen.

1.3 Obtaining On-line Help

A context-sensitive, on-line help system is programmed into every Model GC868 flowmeter. On-line help, which displays additional information related to the current task, may be accessed at any time by pressing the [HELP] key on the keypad. The help information will be shown on the currently selected pane of the display screen, as shown in Figure 1-2 below.

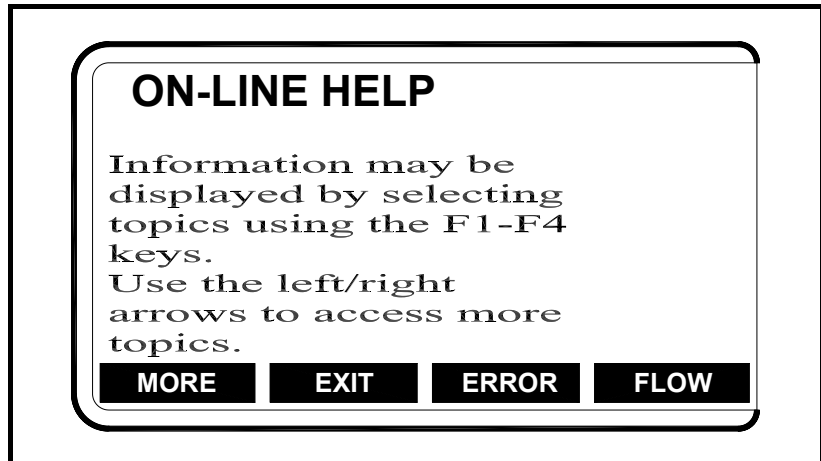

Figure 1-2: Typical On-Line Help Screen

After entering the on-line help system, the following functions are available on the option bar of the selected display pane:

- **MORE:** Press [F1] (or [F5]) to access this function, and the next screen of text is displayed in the prompt area.
- **EXIT:** Press [F2] (or [F6]) to access this function, and the Model GC868 returns to measurement mode.
- **ERROR:** Press [F3] (or [F7]) to access this function, and the various Model GC868 error codes are displayed. Use the [F1]-[F4] (or [F5]-[F8]) function keys, in conjunction with the [←] and [→] keys, to obtain additional information on the desired error code or to exit the help system.

Note: See the Service Manual for a complete listing of all error codes and messages

- **FLOW:** Press [F4] (or [F8]) to access this function, and the various flow measurement parameters are displayed. Use the [F1]-[F4] (or [F5]-[F8]) function keys, in conjunction with the [←] and [→] keys, to obtain additional information on the desired measurement parameter or to exit the help system.

1.4 Using the Console Control Keys

The Model GC868 has four console control keys, which are located on the left side of the keypad. Use these keys, which are described and pictured in Table 1-1 on page 1-3, as follows:

1.4.1 Audio Alarm Volume

Use the top console control key to adjust the audio alarm volume.



Discrete presses will incrementally increase the volume of the audio alarm. Hold the key down for continuous increase. Use the key in shifted mode to decrease the volume of the audio alarm.

1.4.2 Stopwatch Totalizer

Use the second console control key for the stopwatch totalizer.



Press the key once to start the stopwatch totalizer. Press the key once, in shifted mode, to stop the stopwatch totalizer.

Note: *Instructions on properly setting up the stopwatch totalizer are given later in this chapter. Also, the Service Manual provides information on the error response of the stopwatch totalizer.*

1.4.3 Display Brightness

Use the third console control key to adjust the display backlight.



Discrete presses of this key will increase the backlight brightness through settings of Off, Mid and Full. Discrete presses of this key in shifted mode, will decrease the backlight brightness through settings of Full, Mid and Off.

Note: *The display backlight has an automatic time-off feature. See page 1-10 for setup instructions.*

1.4.4 Display Contrast

Use the bottom console key to adjust the display contrast.



Discrete presses will incrementally increase the display contrast. Hold the key down for continuous increase. Use the same key, in shifted mode, to decrease display contrast.

1.5 The User Program

Use the keypad, as described in the previous section, to navigate through the *User Program*. The menu map may be followed in sequence, or the [↑] and [↓] keys may be used to scroll through the prompt screens. The [←] key may be used to delete the last alphanumeric character that was entered from the keypad.

The following discussion assumes that the left screen pane is active. If the right screen pane is active, only the function key designations change. That is, replace [F1]-[F4] with [F5]-[F8].

Note: *Be sure to record all the programming data entered in this chapter in Appendix B, Data Records.*

Programming of the **ACTIV**, **SYSTEM** and **PIPE** submenus is necessary for operation of the Model GC868. Failure to accurately enter all of the required information will result in unreliable flow rate data. Therefore, be sure to complete at least the sections of this chapter pertaining to those three submenus.

Note: *Because it is so essential, instructions for programming the **ACTIV**, **SYSTEM** and **PIPE** submenus are also included in the Startup Guide. If that programming has already been completed, those sections of this chapter may be skipped.*

Except for the three submenus noted above, it is not necessary to program the Model GC868 flowmeter in any particular order. Therefore, the sections of this chapter need not be completed in sequence. Proceed immediately to any section of interest.

1.5.1 Entering Programming Mode

To access the *User Program*, press the **[PROG]** key on the keypad. The standard measurement mode screen is replaced by the following initial programming mode screen:

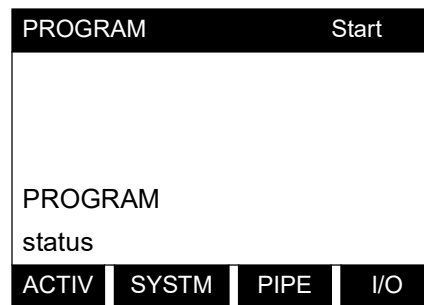

Press the **[←]** and **[→]** keys and one of the function keys **[F1]**-**[F4]** to select the desired submenu. From this screen, press **[EXIT]** to return to measurement mode.

If the security feature is active, enter the password and press the **[ENT]** key to enter the User Program. See the **SECUR** submenu section of this chapter for more information on the security feature.

1.6 Activating the Channel

The **ACTIV** submenu permits selection of the desired measurement method. While following the programming instructions, refer to Figure A-1 on page A-1 of Appendix A, *Menu Maps*.

1. Enter the **ACTIV** submenu by pressing **[F1]** at the **User PROGRAM** prompt. Then press **[F1]** to activate the channel in **BURST** mode.

Note: *The current status of the meter appears in the bottom line.*

2. Press **[F1]** to select *Skon* mode, **[F2]** to select *Skon/Measure Integrate* mode, **[F3]** to select *Skon/Measure Count* mode, or **[F4]** to select *Skon/Correlation* mode. The meter returns to the **PROG** screen.
 - a. If you select *Skon* or *Skon/Measure Count* modes, the GC868 asks if you will *Use 703-1273 DSP?* (the digital signal processing board). Press **[F2]** to apply the board, or **[F1]** to apply the onboard signal processing. (The factory recommends using the DSP for improved response time.)

The Model GC868 can take measurements in four different ways

- *Skon* is a low resolution technique for locating the acoustic signal and for high velocity measurements. It is more robust in a noisy environment than the *Measure* technique. A variation, the *Skon/Correlation* mode, is used primarily for liquid detection applications.
- *Measure* is a more precise technique best used for low velocity measurements. You can choose from *Skon/Measure Count* (the default technique) or *Skon/Measure Integrate* (the traditional *Skon/Measure* mode).

IMPORTANT: Consult with the factory before selecting the *Skon/Correlation* or *Skon/Measure Integrate* modes.

If *Skat* is selected at the next prompt, the instrument uses this technique exclusively. However, if one of the *S/M* modes is selected, the meter uses *Skat* to find the acoustic signal and then tries to use the *Measure* technique for a more precise measurement. To change the *Skat* and *Measure* parameters, see the **SIGNL** and **ADVAN** submenu sections of this chapter.

1.6.1 Procedure Options

After completing the above steps, continue as follows:

- To continue programming the meter, refer to the menu maps in Appendix A and navigate to the desired menu. Then, proceed to the appropriate section of the manual for instructions.
- To leave the *User Program* and retain the previous settings, press **[EXIT]** and then press **[F1] = NO** at the *SAVE* prompt. Any programming changes will be discarded and you will be returned to the data display.
- To leave the *User Program* and return to measurement mode, press **[EXIT]** and then press **[F2] = YES** at the *SAVE* prompt. Your programming changes will be entered into the meter's memory, and you will be returned to the data display.

1.7 Entering System Data

1. At the *User Program* screen, press the **[F2]** function key to program the **SYSTEM** submenu.
2. Enter a *Site Label* of up to 9 characters and press **[ENT]**. (While taking measurements, the site label will appear on the locator bar.)
3. Enter a *Site Message* of up to 21 characters. Press **[ENT]**.

1.7.1 Entering System Units

4. To select the *System Units*, press **[F1]** to display parameters and measurements in English units, or press **[F2]** to display parameters and measurements in Metric units.
5. Use the **[F1]-[F4]** keys to select the type of *Pressure Units* desired. The available pressure units are shown in Figure A-1 on page A-1. The choices shown on the option bar are determined by the selections made at the previous **SYSTEM UNITS** prompt.
 - a. If you have entered the local *Atmospheric Pressure* (PSig, BARg or kPag), use the numeric keys to enter the atmospheric pressure value. Press **[ENT]**.
6. At the *Stopwatch Totalizer* prompt, press **[F1]** to **totalize all liquid flow continuously**, or **[F2]** to measure totals manually with the Stopwatch Timer. (With **MNUAL** (**[F2]**), the console key on the keypad is used to start and stop the totalizer. See page 1-7 for details.)

IMPORTANT: After setting up the Stopwatch Totalizer, press **[CLR]** to clear the Stopwatch Totalizer, or the new totals will be added to any previously accumulated totals.

Note: *The manner in which the Stopwatch Totalizer responds to an error condition may be set in the I/O submenu.*

7. At the *Equation* prompt, press **[F1]** to display the measurement data in *standard* volumetric units or press **[F2]** to display the measurement data in *actual* volumetric units. The Model GC868 will use the appropriate gas equation to calculate the flow rate, corresponding to the measured data, in the volumetric units indicated.
 - a. If you selected *Standard*, press **[F1]** to have the meter treat the gas as an *ideal gas* or press **[F2]** to have the meter treat the gas as a *supercompressed gas*.
8. Use the **[F1]-[F4]** and **[→]** keys to select the desired *Volumetric Units* for the flow rate display. The available volumetric and totalizer units are shown in Figure A-1 on page A-1.
9. Use the **[F1]-[F4]** keys to select the *Volumetric Time* (units for the volumetric flow rate display).
10. Use the **[F1]-[F4]** keys to select the *Val Decimal Digits* (the desired number of digits to the right of the decimal point) in the volumetric flow rate display.

1.7.2 Entering Volumetric Data

1.7.3 Entering Totalizer Data

11. Use the **[F1]-[F4]** and **[→]** keys to select the *Totalizer Units*.
12. Use the **[F1]-[F4]** keys to select the *Total Decimal Digits* (the desired number of digits to the right of the decimal point) in the totalized flow display.

1.7.4 Mass Flow (static)?

13. If the **Static Density?** prompt in the **ADVAN** option (**SETUP** submenu) is set to **NO**, the GC868 returns to the initial *User Program* screen. Otherwise, proceed as follows:

- a. Use the **[F1]-[F4]** keys to select the *Mass Flow* units, listed in Table 1-2 below.

Table 1-2: Available Mass Flow Units

English Mass Flow Units	Metric Mass Flow Units
LB- Pounds	KG - Kilograms
KLB - Thousands of Pounds	
MMLB - Millions of Pounds	
TONS - Tons	Tonnes - Metric Tons

- b. Use the **[F1]-[F4]** keys to select the *Mass Flow Time* units.
- c. Use the **[F1]-[F4]** keys to select the *MDOT DECIMAL DIGITS* (the number of digits to the right of the decimal point) for displaying mass flow.
- d. Use the **[F1]-[F4]** keys to select the *Mass (Totalizer)* units, listed in Table 1-2 above.
- e. Use the **[F1]-[F4]** to specify the **Mass Decimal Digits** (the number of digits to the right of the decimal point) for displaying totalized mass flow. The meter returns to the initial *User (or Channel) Program* screen.

1.7.4.1 Procedure Options

After completing the above steps, the meter returns to the **User PROGRAM** prompt. Continue as follows:

- To continue programming the meter, refer to the menu maps in Appendix A and navigate to the desired menu. Then, proceed to the appropriate section of the manual for instructions.
- To leave the *User Program* and retain the previous settings, press **[EXIT]** and then press **[F1] = NO** at the *SAVE* prompt. Any programming changes will be discarded and you will be returned to the data display.
- To leave the *User Program* and return to measurement mode, press **[EXIT]** and then press **[F2] = YES** at the *SAVE* prompt. Your programming changes will be entered into the meter's memory, and you will be returned to the data display.

1.8 Entering Pipe Data

The **PIPE** submenu permits entry of the transducer and pipe specifications. To program this menu, complete the following steps:

1. At the *User Program* screen, press **[F3]** to program the **PIPE** submenu.
2. Enter the *Transducer Number* (normally engraved on the head of the transducer). Press **[ENT]**. If there is no engraved number, complete the steps below. Otherwise, proceed to step 3.

IMPORTANT: Special transducers, which have no engraved number on the head, are rarely used. Examine the transducer head carefully for a number.

1.8.1 Special Transducers

- a. Assign a number between 91 and 99 to the *Special Transducer* and press **[ENT]**. (The meter will only accept values from 1 to 199.)
- b. Press **[F2]** to select Shear wave as the *Transducer Type*.

Note: *While three choices are available (Rayleigh, Shear wave or wetted transducers), the GC868 is designed for use with Shear wave clamp-on transducers. Consult the factory before selecting Rayleigh or wetted transducers.*

1.8.2 Wedge Temperature
1.8.3 Pipe Material

- c. Use the [→] and [F1]-[F4] keys to select the **Frequency of the special transducer**. The meter can not transmit an excitation voltage at the transducer’s natural frequency without this data.
 - d. Press [F1]-[F4] to select the *Wedge Material*. The available options include **VHT** (very high temperature), **MT** (medium temperature), **HT** (high temperature) and **OTHER**. Refer to the data sheet supplied with your transducer to determine the appropriate setting.
 - e. Use the numeric keys to enter the *Wedge Angle* (the angle of the ultrasonic transmission) supplied by the factory in degrees and press [ENT].
 - If you selected **OTHER** in step d, use the numeric keys to enter the *Wedge Soundspeed* in ft/sec or m/sec supplied by Panametrics and press [ENT]. The meter proceeds to step 5.
3. Use the numeric keys to enter the *Wedge Temperature* supplied by the factory in deg F and press [ENT].
 4. Press [F1]-[F4] to select the *Pipe Material*. Press [→] to access additional options, as listed in Table 1-3 below.

Table 1-3: Pipe Materials

Category	Specific Material
Steel	Carbon Steel or Stainless Steel
Iron	Ductile Iron or Cast Iron
Cu - Copper	None
Al - Aluminum	None
Brass	None
CuNi - Copper/Nickel	70% Cu 30% Ni or 90% Cu 10% Ni
Glass	Pyrex, Flint, or Crown
Plastic	Nylon, Polyester, Polypropylene, PVC (CPVC), Acrylic
Other*	Any material

1.8.4 Pipe OD

- Depending on the pipe material choice, another prompt may ask you to select the *Specific Material*.
 - If you have selected “Other,” enter the pipe material *Sound Speed*. Press [ENT].
5. Enter the known *Pipe OD* or circumference and use the [F1]-[F4] keys to select the appropriate units. Press [ENT]. (The meter will only accept values from 1/8 to 648 in.)

The required pipe data may be obtained by measuring either the pipe outside diameter (OD) or circumference at the transducer installation site. The data may also be obtained from standard pipe size tables (see the Panametrics document *Sound Speeds and Pipe Size Data*, #914-004). For a list of the available English and Metric units and their definitions for the **PIPE OD** prompt, refer to Table 1-4 on page 1-11.

Table 1-4: Available Pipe OD Units

English	Metric
inch = pipe OD in inches	mm = pipe OD in millimeters
feet = pipe OD in feet	m = pipe OD in meters
in/PI = pipe circumference in inches	mm/PI = pipe circumference in millimeters
ft/PI = pipe circumference in feet	m/PI = pipe circumference in meters

- 1.8.5 Pipe Wall**
6. Enter the known thickness of the *Pipe Wall*, in the same units used for the pipe OD. Press **[ENT]**. (The meter will only accept values from 0 to 4 in.)
- If the pipe wall thickness is not known and cannot be conveniently measured, look up the value in a table of standard pipe size data or use the Model GC868's on-line *Help Menu*.
- 1.8.6 Fluid Type**
7. Press **[F1]** = natural gas, **[F2]** = air, **[F3]** = steam, or **[F4]** = any other gas to select the *Fluid Type*. If **OTHER** was selected, enter the speed of sound (in feet per second) in the gas to be measured. Press **[ENT]**. (The meter will only accept values from 125 to 9000 ft/sec.)
- 1.8.7 Reynolds Correction**
8. The *Reynolds Correction* factor is a number based on the kinematic viscosity and flow rate of the gas. At the prompt, press **[F1]** to turn **Reynolds Correction off**, or **[F2]** to turn it on.
- If you select Reynolds Correction, the GC868 asks for the *Kinematic Viscosity* of the gas (available in the brochure *Sound Speeds and Pipe Size Data*, 914-004). Use the numeric keys to enter the correct value and press **[ENT]**.
- 1.8.8 Calibration Factor**
9. Enter a value for the flow *Calibration Factor* and press **[ENT]**. The default value is 1.00. (The meter will only accept values from 0.5000 to 2.0000.) If you are using wetted transducers, you have completed programming in the **PIPE** menu.
- 1.8.9 Number of Traverses**
10. Press **[F1]**–**[F4]** to select the desired number of traverses (times the ultrasonic signal traverses the pipe, from 1 to 9).
- Note:** *Most clamp-on gas applications require a single traverse (1(Z)).*
- 1.8.10 Transducer Spacing**
11. The *Transducer Spacing* prompt displays the spacing of the transducers, as calculated from the information you have entered. Record this number in Appendix B, *Data Records*, and use it to properly space the transducers.
- Note:** *If necessary, you can overwrite the spacing shown at the previous prompt (using the numeric keys) to match the actual physical spacing of the transducers. Panametrics does not recommend overwriting the spacing. If you must, do not change the spacing by more than ±10% from the value shown.*
- 1.8.10.1 Procedure Options**
- After completing the above steps, the meter returns to the *User Program* prompt. Continue as follows:
- To continue programming the meter, refer to the menu maps in Appendix A and navigate to the desired menu. Then, proceed to the appropriate section of the manual for instructions.
 - To leave the *User Program* and retain the previous settings, press **[EXIT]** and then press **[F1] = NO** at the *SAVE* prompt. Any programming changes will be discarded and you will be returned to the data display.
 - To leave the *User Program* and return to measurement mode, press **[EXIT]** and then press **[F2] = YES** at the *SAVE* prompt. Your programming changes will be entered into the meter's memory, and you will be returned to the data display.
- 1.9 Setting Up Inputs/Outputs**
- Set up the GC868's inputs and outputs via the four options in the **I/O** submenu. While following the programming instructions, refer to Figure A-2 on page A-2 of Appendix A, *Menu Maps*.
- ERROR** - program the meter's response during an error condition
 - OPTN** - set up the **Slot 0** analog outputs and any option cards
 - ZERO** - set the meter's zero point cutoff value
 - T,P** - set up the temperature and pressure inputs

Enter the **I/O** submenu by pressing **[F4]** at the initial *User Program* screen. Then press **[F1]-[F4]** to select the desired **I/O** option.

Note: *In this section, a slot's number will appear on the option bar only if an option card is installed in that slot. The generic designations **Slot x** and **Fx** are used to indicate any one of the expansion slots and the function key used to select it.*

Proceed to the appropriate section to program the option selection made at the above prompt. Remember to record all programmed data in Appendix B, *Data Records*.

1.9.1 Selecting Error Handling

This menu option permits programming of the manner in which the Model GC868's totalizers respond during an error condition. See Chapter 2, *Error Codes and Screen Messages*, of the *Service Manual* for a discussion of the built-in error codes.

1. At the **I/O** prompt, press **[F1]** = Error.
2. Press **[F1]** if you want the **GC868** to Hold the last "good" reading and continues to totalize, based on that reading, or press **[F2]**, **No Up**, if you want the meter to stop totalizing.

1.9.2 Setting Up Analog Outputs

The Model GC868 has two built-in analog outputs, which are assigned to **Slot 0**. Also, a variety of option cards may be installed in the six expansion slots. See Chapter 1, *Installation*, of the *Startup Guide* for a complete description of the available option cards.

This menu option is used to set up and/or scale the analog inputs and outputs. To accomplish this, complete the following steps:



Use the **[←]** and **[→]** and the **[F1]-[F4]** keys to select the desired slot number. (Only those slots which contain an option card will appear on the option bar.)

If the number of a slot with an installed option card does not appear, the card may not have been initialized or it may be defective. Call the factory for assistance.

Complete the following steps to set up the **Slot x** analog outputs:

1. Use the **[F1]-[F4]** keys to set up outputs A, B, C or D, respectively.
- Note:** *The set up of output A is used as an example. Identical procedures would be used to set up the other outputs.*
2. Press **[F1]** = **OFF** to disable output A and return to the previous prompt, or press **[F2]** = **0-20 m** or **[F3]** = **4-20 mA** to specify the desired range for output A.
 3. Use the **[←]** and **[→]** and **[F1]-[F4]** keys to specify the desired *Output Measurement* parameter (see Figure A-2 on page A-2).
 4. Enter the *Zero* value for the low end of the chosen output range. Press **[ENT]**.
 5. Enter the *Full* value for the high end of the chosen output range. Press **[ENT]**.
 6. Press **[F1]-[F4]** to select the desired *Error Response* option, as described in Table 1-5 on the next page.

Table 1-5: Error Response Options

Option	Display Response
HOLD	Holds the last "good" reading.
LOW	Forces the outputs to the low set point.
HIGH	Forces the outputs to the high set point.
OTHER	Allows user to enter 4-20 mA error level in mA.

- Use the **[F1]**-**[F4]** keys to set up another output or press **[EXIT]** to select another slot for setup.

For instructions on setting up additional inputs and/or outputs proceed to the appropriate section. Otherwise, press **[EXIT]** to return to the main **I/O** menu prompt.

1.9.3 Option Card Alarms

- Use the **[←]** and **[→]** and the **[F1]**-**[F4]** keys to select the desired slot number.
- Use the **[F1]**-**[F3]** keys to set up alarm relays A, B, or C, respectively.

Note: *The set up of alarm A is used as an example. Identical procedures would be used to set up the other alarms.*

- Press **[F1] = OFF** to disable Alarm A and return to the previous prompt, or press **[F2] = HIGH**, **[F3] = LOW** or **[F4] = FAULT** to specify the type for Alarm A.
- Press **[F1] = NO** for standard operation or **[F2] = YES** for *Failsafe* operation.
- Do one of the following:
 - If you selected **FAULT**, proceed to step 6.
 - If you selected **HIGH** or **LOW**, complete the steps below.
 - Use the **[←]** and **[→]** and **[F1]**-**[F4]** keys to specify the desired *Output Measurement* parameter, as shown in Figure A-2 on page A-2.
 - Enter a value for the trigger point of the alarm and press **[ENT]**.
- Press **[F1]**-**[F3]** to set up another alarm or press **[EXIT]** to select another slot for set up.

For instructions on setting up additional inputs and/or outputs proceed to the appropriate section. Otherwise, press **[EXIT]** to return to the main **I/O** menu prompt.

1.9.4 Setting Up the Totalizer/Frequency Outputs

- Use the **[←]** and **[→]** and the **[F1]**-**[F4]** keys to select the desired slot number.
- Press **[F1]**-**[F4]** to set up outputs A, B, C or D, respectively.
- Press **[F1] = OFF** to disable output A and return to the previous prompt, or press **[F2] = FREQ** or **[F3] = TTLZR** to designate output A as a frequency or a totalizer output, respectively.

Note: *The setup of output A is used as an example. Identical procedures would be used to set up the other outputs.*

- To program a frequency output, go to step 4.
- To program a totalizer output, go to step 5.

1.9.4.1 Programming a Frequency Output

- The **FREQ** output, **[F2]**, produces a frequency pulse that is proportional to the output measurement. Complete the steps below to program the frequency output.
 - Use the **[←]** and **[→]** and **[F1]**-**[F4]** keys to specify the desired *Output Measurement* parameter.
 - Enter the *Base* value for the low end of the frequency output range and press **[ENT]**.
 - Enter the *Full* value for the high end of the frequency output range. Press **[ENT]**.

- d. Enter a value between 1 and 10,000 for the *Full Scale Frequency*. Press **[ENT]**.
- e. Use the **[F1]**-**[F4]** keys to select the desired *Error Option*, the way the display responds during an error condition. Available options are shown in Table 1-6 below. Then skip to step 6 on the next page.

Table 1-6: Error Response Options for Frequency Output

Option	Display Response
HOLD	Holds the last "good" reading.
LOW	Forces the outputs to the low setpoint.
HIGH	Forces the outputs to the high setpoint.
OTHER	Allows user to enter Hertz error level.

1.9.4.2 Programming a Totalizer Output

5. The **TTLZR** output, **[F3]**, issues one pulse per selected volume of flow. The meter produces a pulse each time the programmed amount of flow passes through the pipe. Complete the steps below to program the totalizer output.

- a. Press **[F1] = +TOTL** to totalize the forward flow, **[F2] = -TOTL** to totalize the reverse flow, **[F3] = +MASS** (if available) to totalize the forward mass flow or **[F4] = -MASS** (if available) to totalize reverse mass flow.
- b. Enter a value from 50 to 500,000 μ sec for the *Minimum Pulse ON Time* and press **[ENT]**.

Note: *A complete pulse consists of equal amounts of ON and OFF times. Choose a value that is compatible with the frequency counter to be used.*

- c. Enter a value for the number of measurement *Units/Pulse* and press **[ENT]**.

6. Press **[F1]**-**[F4]** to set up another totalizer/frequency output or press **[EXIT]** to select another slot for setup.

1.9.5 Setting up the Analog Inputs

1. Use the **[←]** and **[→]** and the **[F1]**-**[F4]** keys to select the desired slot number.
2. Press **[F1]** to set up input A or **[F2]** to set up input B.

Note: *The set up of input A is used as an example in this manual. Identical procedures would be used to set up input B. (An analog input option card may contain one standard analog input and one RTD analog input.)*

3. Enter a *Label* of up to eight characters for input A and press **[ENT]**.
4. At the *Input Measurement* prompt, press **[F1] = OFF** to disable input A and return to the previous prompt, or press **[F2] = PRESR (pressure)**, **[F3] = TEMP (temperature)** or **[F4] = SPEC (special)** to designate the input.
5. Do one of the following:
 - If you selected **PRESR** or **TEMP**, proceed to step 6.
 - If you selected **SPEC**, complete the steps below.
 - a. Enter an *Input Name* and press **[ENT]**.
 - b. Enter the *Input Units* of measurement and press **[ENT]**.
6. Enter the *Zero Value* for the low end of the chosen input range and press **[ENT]**.
7. Enter the *Full Scale Value* for the high end of the chosen input range and press **[ENT]**.
8. Press **[F1]**-**[F2]** to set up another input or press **[EXIT]** to select another slot for setup.

For instructions on setting up additional inputs and/or outputs proceed to the appropriate section. Otherwise, press **[EXIT]** to return to the main **I/O** menu prompt.

1.9.6 Setting up RTD Inputs

Option cards with RTD inputs have a temperature range of -100° to 350°C . Complete the following steps to set up the two RTD inputs of an option card installed in Slot x:

1. Use the [←] and [→] and the [F1]-[F4] keys to select the desired slot number.
2. Press [F1] to set up RTD input A or [F2] to set up RTD input B.

Note: *The setup of RTD input A is used as an example. Identical procedures would be used to set up RTD input B.*

3. Enter a label of up to eight characters and press [ENT].
4. At the Input Measurement prompt, press [F1] = OFF to disable RTD input A and return to the previous prompt, or press [F2] = TEMP to enable RTD input A.
5. Enter the *Zero Value* for the low end of the chosen input range and press [ENT].
6. Enter the *Full Scale Value* for the high end of the chosen input range and press [ENT].
7. Press [F1]-[F2] to set up another input or press [EXIT] to select another slot for set up.

For instructions on setting up additional inputs and/or outputs proceed to the appropriate section. Otherwise, press [EXIT] to return to the main I/O menu prompt.

1.9.7 Entering the Zero Cutoff

Near zero flow, the Model GC868's readings may fluctuate due to small offsets caused by thermal drift or similar factors. To force a zero reading when there is minimal flow, enter a zero cutoff value as described below:

1. At the main I/O menu prompt, press [F3] = ZERO.
2. Enter the desired **Zero Cutoff** value and press the [ENT] key. A value of 0.1 ft/s (0.03 m/s) is recommended, but values from 0–1 ft/s (0–0.3 m/s) are acceptable. The menu returns to the main I/O prompt.

1.9.8 Setting Up Temperature and Pressure Inputs

Note: *This option only appears if you have selected "Standard" as the equation type in the SYSTM submenu, as shown on page 1-9.*

The Model GC868 can use either fixed temperature and pressure quality values or live measurement inputs to calculate standard volumetric or mass flow. Complete the following steps to configure these inputs:

1. At the main I/O menu prompt, press [F4] = T,P.
2. At the *Temperature Input* prompt, press [F1] to enter a constant temperature value or press [Fx] to select the option card in Slot x that will supply the live temperature input.

1.9.8.1 Entering the Temperature Input

Note: *Each slot that contains an option card with an analog input assigned to TEMP or an RTD input will appear on the option bar. If the process temperature is stable, a fixed value may be used, but most applications require a live temperature input.*

3. Do one of the following:
 - If you selected **FIXED**, enter the known fixed process temperature. Press [ENT]. (The meter will only accept values from -148° to 662°F .)
 - If you selected **SLOT X**,
 - a. Press [F1] to select input A or press [F2] to select input B. The inputs were labeled during setup.

Note: *The set up of input A is used as an example. Identical procedures would be used to set up input B.*

- b. Enter the *Base Temperature* (from -148° to 662°F), and press [ENT]. The ratio of this value to the actual temperature is used to calculate the standard volumetric flow.

1.9.8.2 Entering the Pressure Input

4. At the *Pressure Input* prompt, press **[F1]** to enter a constant pressure value or press **[Fx]** to select the option card in Slot X that will supply the live pressure input.

Note: *Each slot that contains an option card with an analog input assigned to **PRESR** will appear on the option bar. If the process pressure is stable, a fixed value may be used, but most applications require a live pressure input.*

5. Do one of the following:
 - If you selected **FIXED**, enter the known fixed process pressure. Press **[ENT]**. (The meter will only accept values from 0–5000 psia.)
 - If you selected **SLOT X**,
 - a. Press **[F1]** to select input A or press **[F2]** to select input B. The inputs were labeled during setup.
 - b. Enter the *Base Pressure* (standard) value for the process, and press the **[ENT]** key. (The meter will only accept values from 0 to 7508 psia, or 0 to 500 bar.)

If you selected a supercompressed gas in the **SYSTM** menu, a series of additional prompts appears. Otherwise, the program returns to the main **I/O** menu prompt.

- c. Enter the *Specific Gravity for the Forward Flow* and press **[ENT]**. (The meter will only accept values from 0.1000 to 1.5000.)
- d. Enter the *Specific Gravity for the Reverse Flow* and press **[ENT]**. (The meter will only accept values from 0.1000 to 1.5000.)
- e. Enter the *Percentage of Carbon Dioxide for the Forward Flow* and press **[ENT]**. (The meter will only accept values from 0 to 40%.)
- f. Enter the *Percentage of Carbon Dioxide for the Reverse Flow* and press **[ENT]**. (The meter will only accept values from 0 to 40%.)
- g. Press **[F1]** to select a *Fixed Nitrogen Forward Input*.
- h. Enter the *Percentage of Nitrogen for the Forward Flow* and press **[ENT]**. (The meter will only accept values from 0 to 40%.)
- i. Press **[F1]** to select a *Fixed Nitrogen Reverse Input*.
- j. Enter the *Percentage of Nitrogen for the Reverse Flow* and press **[ENT]**. (The meter will only accept values from 0 to 40%.)

Press **[F1]-[F4]** to select another option or press **[EXIT]** to return to the initial *User Program*.

1.9.8.3 Procedure Options

After completing the above steps, the meter returns to the main **I/O** prompt. Continue as follows:

- To continue programming the meter, refer to the menu maps in Appendix A and navigate to the desired menu. Then, proceed to the appropriate section of the manual for instructions.
- To leave the *User Program* and retain the previous settings, press **[EXIT]** and then press **[F1] = NO** at the *SAVE* prompt. Any programming changes will be discarded and you will be returned to the data display.
- To leave the *User Program* and return to measurement mode, press **[EXIT]** and then press **[F2] = YES** at the *SAVE* prompt. Your programming changes will be entered into the meter's memory, and you will be returned to the data display.

1.10 Entering Setup Data

The signal limits and response times for the Model GC868 are specified via the **SETUP** submenu. While following the programming instructions, see Figure A-3 and Figure A-4 in Appendix A, *Menu Maps*. The following four submenus are included in this section:

- **SIGNL** – set the parameters related to the transducer signal
- **AVRG** – specify the response of the meter to step changes
- **INIT** – initialize all parameters to default values.
- **ADVAN** – setting parameters for special operations.

Enter the **SETUP** submenu by pressing [→] and [F1] at the initial *User Program* screen and complete the following steps:

SETUP	Press [F1]–[F3] to select the desired SETUP option.
PROGRAM	
SET UP	
SET UP	
last selection appears here	
SIGNL AVRG INIT ADVAN	

Proceed to the appropriate section to program the option selection made at the above prompt. Remember to record all programmed data in Appendix B, *Data Records*.

1.10.1 Setting Signal Limits

Use this option to set the limits for the incoming signal and other parameters affecting the transducer signal. For example, the programmed signal strength low limit may be used to determine the trigger point for an alarm.



CAUTION! The **SIGNL** default settings are suitable for most applications. Before changing any of these parameters, consult the factory.

Complete the following steps to enter the signal parameters:

1. To enter the **SIGNL** submenu, press [F1] at the **SETUP** window.
2. Press [ENT] to accept the current **Signal Low Limit** value or enter a new value and press [ENT].

The default value for this parameter is 50 and values from –20 to 100 are acceptable. The **E1: LOW SIGNAL** error message appears when the signal strength falls below the programmed **SIGNAL LOW LIMIT** value. See the *Service Manual* for a discussion of error codes.

3. Press [ENT] to accept the current **Signal High Limit** value or enter a new value and press [ENT].

The default value for this parameter is 68 and values from 25 to 100 are acceptable. The **E16: HIGH SIGNAL** error message appears when the signal strength falls above the programmed **SIGNAL HIGH LIMIT** value. See the *Service Manual* for a discussion of error codes.

4. Press [ENT] to accept the current **Cor. Peak Limit** value or enter a new value and press [ENT].

The default value for this parameter is 100 and values from 0 to 500 are acceptable. The **E4: SIGNAL QUALITY** error message appears when the signal quality falls below the programmed **COR. PEAK LIMIT** value. See the *Service Manual* for a discussion of error codes.

5. Press **[ENT]** to accept the current **Soundspeed +- Limit** value or enter a new value and press **[ENT]**.

The default value for this parameter is 10% and values from 1% to 50% are acceptable.

6. Press **[ENT]** to accept the current **Velocity Low Limit** value or enter a new value and press **[ENT]**.

The default value for this parameter is -75.0 ft/sec (-23 m/sec) and values from -500 to 500 ft/sec (-150 to 150 m/sec) are acceptable. The **E3: VELOCITY RANGE** error message appears when the calculated fluid velocity is less than the programmed **VELOCITY LOW LIMIT** value. See the *Service Manual* for a discussion of error codes.

Note: *The actual maximum velocity depends on your application. Refer to Tables 1-1 to 1-3 of the Startup Guide for a list of maximum velocities.*

7. Press **[ENT]** to accept the current **Velocity High Limit** value or enter a new value and press **[ENT]**.

The default value for this parameter is 75.0 ft/sec (23 m/sec) and values from -500 to 500 ft/sec (-150 to 150 m/sec) are acceptable. The **E3: VELOCITY RANGE** error message appears when the calculated fluid velocity exceeds the programmed **VELOCITY HIGH LIMIT** value. See the *Service Manual* for a discussion of error codes.

8. Press **[ENT]** to accept the current **Acceleration** value or enter a new value and press **[ENT]**.

The default value for this parameter is 5.0 ft/sec² (4.6 m/sec²) and values from 0 to 100 ft/sec² (0 to 30 m/sec²) are acceptable. The **E6: CYCLE SKIP** error message appears when the calculated fluid velocity changes by more than the programmed **ACCELERATION LIMIT** value from one reading to the next. See the *Service Manual* for a discussion of error codes.

9. Press **[ENT]** to accept the current **Amp. Discrim Low** value or enter a new value and press **[ENT]**.

IMPORTANT: Consult the factory before performing this step.

The amplitude discriminator measures the size of the transducer signal received by the Model GC868. The default value for this parameter is 14 and values from 0 to 100 are acceptable. The **E5: AMPLITUDE** error message appears when the amplitude discriminator falls below the programmed **AMP. DISCRIM LOW** value. See the *Service Manual* for a discussion of error codes.

10. Press **[ENT]** to accept the current **Amp. Discrim High** value or enter a new value and press **[ENT]**.

IMPORTANT: Consult the factory before performing this step.

The amplitude discriminator measures the size of the transducer signal received by the Model GC868. The default value for this parameter is 34 and values from 0 to 100 are acceptable. The **E5: AMPLITUDE** error message appears when the amplitude discriminator exceeds the programmed **AMP. DISCRIM HIGH** value. See the *Service Manual* for a discussion of error codes.

11. Press **[ENT]** to accept the current **Delta T Offset** value or enter a new value and press **[ENT]**.

IMPORTANT: Consult the factory before performing this step.

An offset between the upstream and downstream transit times is specified at this prompt. The default value for this parameter is 0 μ sec and values from -1000 to 1000 μ sec are acceptable.

12. Press **[ENT]** to accept the current **Skam T Offset** value or enter a new value and press **[ENT]**.

At this prompt, specify a time measurement offset that compensates for any shift resulting from cross-correlation. The default value for this parameter is 12.6 μ sec and values from -500 to 500 μ sec are acceptable.

Note: *If you enter a value of 0 for this command, you enable a special mode of operation, ACTIVE SKAN T-OFFSET, that dynamically calculates the offset.*

13. Press **[ENT]** to accept the current **% of Peak** value or enter a new value and press **[ENT]**.

The percentage of peak used to calculate the transit times and Delta T is specified at this prompt. The default value for this parameter is 50% and values from 1 to 100% are acceptable.

14. Use the **[→]** and **[F1]-[F4]** keys to select one of the preset values for the **XMIT Sample Size** from the option bar.

IMPORTANT: Consult the factory before performing this step.

Both the upstream and downstream transducers transmit ultrasonic pulses in bursts, which consist of a series of transmit pulses. **XMIT SAMPLE SIZE** determines how many bursts are sent in one direction before sending in the other direction. The default value for this parameter is 8 and values of 2, 4, 8, 16 and 32 are acceptable.

15. Press **[ENT]** to accept the current **M>S_Switch** value or enter a new value and press **[ENT]**.

IMPORTANT: Consult the factory before performing this step.

If the burst mode is set to Skan/Measure (S/M), the meter switches from Skan to Measure Mode when Delta T is less than the **M>S_Switch** value. **DO NOT** change this value unless advised to do so by the factory. The default value for this parameter is 50 μ sec and values from 0 to 250 μ sec are acceptable.

16. Press **[ENT]** to accept the current **# shifts** value or enter a new value and press **[ENT]**.

The number of shifts corresponds to the actual number of transmits per cycle (number of signals added together in one direction to produce an averaged signal for one interrogation of the fluid) and need only be changed if the environment is very noisy or the acoustic signal is weak. The default value for this parameter is 3 and values from 0 to 10 are acceptable.

17. Press **[ENT]** to accept the current **A Divisor** value or enter a new value and press **[ENT]**.

A Divisor is used in the calculation of the Measure Mode integrated threshold level and is not normally changed. The default value for this parameter is 2.5 and values from 0.1 to 10 are acceptable.

18. Press **[ENT]** to accept the current **# Transmit Pulses** value or enter a new value and press **[ENT]**.

IMPORTANT: Consult the factory before performing this step.

Transmit Pulses specifies the number of pulses in a burst. The default value for this parameter is 1 and values from 1 to 16 are acceptable. For difficult conditions (i.e., long paths, high velocity or high temperature), settings as high as 16 may be necessary.

19. Press **[ENT]** to accept the current **T Window (Cycles)** value or enter a new value and press **[ENT]**.

IMPORTANT: Consult the factory before performing this step.

Normally, the Model GC868 calculates the size of the transmit window based on pipe size and fluid sound speed. However, for special diagnostic purposes, it may sometimes be necessary to reset the window size. The default value for this parameter is 0 and values from 0 to 1,000 are acceptable. If you select 0 or 1, the GC868 applies automated calculation, and the following prompt does not appear.

20. Press **[ENT]** to accept the current **R WINDOW (cycles)** value or enter a new value and press **[ENT]**.

IMPORTANT: Consult the factory before performing this step.

Normally, the Model GC868 calculates the size of the receive window based on pipe size and fluid sound speed. However, for special diagnostic purposes, it may sometimes be necessary to reset the window size. The default value for this parameter is 10 and values from 10 to 128 are acceptable.

After completing these steps, the program returns to the **SETUP window**. Table 1-7 on the next page lists the default values and limits for SETUP parameters.

**Table 1-7: Default Values and Limits for GC868
SETUP Parameters**

Parameter	Default Value	Low Limit	High Limit
Signal Low Limit	50	-20	100
Signal High Limit	68	25	100
Cor. Peak Limit	400	0	500
Soundspeed ± Limit	10%	1%	50%
Velocity Low Limit	-75.0 ft/sec (-23 m/sec)	-500 ft/sec (-150 m/sec)	+500 ft/sec (+150 m/sec)
Velocity High Limit	75.0 ft/sec (23 m/sec)	-500 ft/sec (-150 m/sec)	+500 ft/sec (+150 m/sec)
Acceleration Limit	5.0 ft/sec ² (4.6 m/sec ²)	0	100 ft/sec ² (30 m/sec ²)
Amp. Discrim Low	14	0	100
Amp. Discrim High	34	0	100
Delta T Offset	0	-1,000 μsec	1,000 μsec
Skat T Offset	12.6 μsec	-500 μsec	500 μsec
% of Peak	80%	1%	100%
XMIT Sample Size	8	2	32
M>S Switch	5 μsec	0 μsec	250 μsec
# shifts	3	0	10
A Divisor	2.5	0.1	10
# Transmit Pulses	1	1	16
T Window	1	0	1,000
R Window	10	10	128

1.10.2 Setting Response Time

Use this option to specify the number of readings that occur before the meter will respond to a step change in flow rate. In general, the smaller the number of readings, the less steady the display will appear.

1. To enter the **AVRG** submenu, press **[F2]** at the **SETUP** window.
2. Use the **[→]** and **[F1]-[F4]** keys to select the desired option. The available response time options are **1, 2, 5, 10, 30, 60 and STATS**. For best results, select **STATS** (statistics), as this increases the response time under steady flow conditions while still allowing a rapid response to changes in flow rate.

The GC868 program returns to the **SETUP** window. Remember to record all programmed data in Appendix B, *Data Records*.

1.10.3 Initializing the System

Use this option to initialize (reset) all of the parameters within the **SETUP** menu to their default values.

1. To enter the **INIT** submenu, press **[F3]** at the **SETUP** window.
2. Press **[F1] = NO** to keep the current values or press **[F2] = YES** to reset all values to their default settings.

1.10.4 Setting Advanced Parameters

In the **ADVAN** option, you can enter parameters for a variety of specialized operations. You can set parameters for static density, program tables for steam or natural gas and for multiple K factors, and modify parameters for the Skan and Skan/Measure techniques. While following the programming instructions, refer to Figure A-4 on page A-4 of Appendix A, *Menu Maps*. To enter the **ADVAN** submenu, press **[F4]** at the **SETUP** window.

1.10.4.1 Static Density

Use this option to specify basic parameters for mass flow measurement.

1. To enter the **MASS** submenu, press **[F1]** at the **ADVAN** window.
2. At the *Static Density?* prompt, press **[F1] = NO** or **[F2] = YES**. If you press **NO**, the GC868 returns to the **ADVAN** window.
3. If you press **YES**, select the *Density Type to calculate Mass Flow*: **[F1] = Rho** (Fluid Density) or **[F2] = Mw** (Molecular Weight).
4. The next prompt depends upon your selection in step 3.
 - If you select *Rho*,
 - a. The GC868 asks for the type of volumetric flow. Press **[F1]** to select **AcVOL (Actual Volumetric Flow)** or **[F2]** to select **StVOL (Standard Volumetric Flow)**.
 - b. Then enter the *Fluid Density* of the gas to be measured and press **[ENT]**. (The meter will only accept values from 0.00001–100 lb/ft³.)
 - If you select *Mw*,

Enter the Molecular Weight of the gas to be measured and press **[ENT]**.

The GC868 program returns to the **ADVAN** window.

1.10.4.2 Setting the A Value

In the Skan/Measure Integrate mode, the A value aids in minimizing cycle skipping. Use this option to specify parameters for the A value.

IMPORTANT: The **AVAL** default settings are suitable for most applications. Before changing any of these parameters, consult the factory.

1. To enter the **AVAL** submenu, press **[F2]** at the **ADVAN** window.
2. Use the numeric keys to enter the desired *A_ Value Minimum*, and press **[ENT]**. (The available range is from 75 to 100, and the default value is 75.)
3. Use the numeric keys to enter the desired *A_ Value Maximum*, and press **[ENT]**. (The available range is from 100 to 125, and the default value is 125.)
4. Enter the desired *-Offset % of Peak* from 0 to 95%, and press **[ENT]**. (The default value is 20%.)
5. Enter the number of *Cycle Count Samples* (from 1 to 40) and press **[ENT]**. (The default number is 8.)
6. Enter the *Cycle #* (from 1 to 100) and press **[ENT]**. (The default number is 1.)

The GC868 returns to the **ADVAN** window.

1.10.4.3 Setting Skan/Measure Parameters

Use the **MEAS** option to modify the parameters of the Skan/Measure modes.

IMPORTANT: The **MEAS** default settings are suitable for most applications. Before changing any of these parameters, consult the factory.

1. Press **[F3]** to enter the *Measurement Settings* option.
2. The first prompt asks for the number of cycles in the *MEAS R Window*. While this window is normally 24 cycles wide, the option allows you to customize the width from 1 to 60. Press **[ENT]** to accept the current value, or enter a new value and press **[ENT]**.
3. Press **[F1]** to use both skan and measure times, or **[F2]** to *Use Meas Times only*. (The default setting is "Yes".)
4. Press **[F1]** to retain skan, or **[F2]** to *Skip Skan*. If **[F2]** is selected, the GC868 will skip skan except for every 10th reading, when an error appears, or when the Delta-T exceeds the M>S Switch limit.
5. At the *SkanDT>MeasDT Check?*, press **[F1]** to omit a test to determine whether the Skan Delta T is greater than the Measure Delta T, or **[F2]** to apply the test. (The default setting is "No".)
6. Enter a value (from 0 to 100 μ sec) for the *Absolute Skan Delta T* to be used in the test in step 5, and press **[ENT]**. (The default is 4.)
7. The next prompt, *Normalize to 100?*, asks if the program will keep the Skan Delta T within the 0 to 100 range (?), rather than the actual amplitude. Press **[F1]** to use actual amplitude, or **[F2]** to normalize the parameter. (The default setting is "No".)
8. Press **[F1]** to omit measurement of SNR (signal to noise ratio), or **[F2]** to measure SNR. (The default setting is "Yes.")
 - a. If you measure SNR, the program asks for the *Minimum SNR for Error 4*. (The default is 7.0.) Enter the desired value, and press **[ENT]**.

The GC868 returns to the **ADVAN** window.

1.10.4.4 Entering Multiple K Factors

In the **MULTK** option, you can enter velocity or Reynolds Correction values into a K-Factor table. You can thus “curve fit” velocity or Reynolds calibration multiple data points (from several different data sources or flow variables) to the flow rate reported by the GC868.

1. Press **[F4]** to enter the *Multiple K Factors* option.
2. Press **[F1] = NO** to disable or **[F2] = YES** to enable *Multiple K-factors*.
 - If you press **NO**, the GC868 returns to the **ADVAN** window.
3. If you press **YES**, the program asks for the *Custom type* of data. Press **[F1]** to select velocity data, or **[F2]** to select Reynolds data.
 - a. If you select a Reynolds table, the meter asks for the *Kinematic Viscosity*. Enter the appropriate value, and press **[ENT]**.
4. Press **[F1] = NO** to retain the current K-factor table and return to the **ADVAN** window, or press **[F2] = YES** to *Edit The K-factor Table*.

Note: *If velocity vs. K-factor data was not provided with the Model GC868, the K-factor table can not be edited.*

- a. Enter the *Number of K-factors* to be entered into the table. Press **[ENT]**. (The meter will only accept values from 2 to 20.)

IMPORTANT: When editing the K-factor table, the velocities must be entered in increasing order.

- b. Enter the *Velocity (or Reynolds) Value* for K-factor number “x”. Press **[ENT]**. (The meter will only accept values from –30,000 to +30,000 ft/sec.)
- c. Enter the *K-factor* corresponding to velocity or Reynolds number “x”. Press **[ENT]**.
- d. Repeat steps b and c until all of the data points have been entered.

The GC868 returns to the **ADVAN** window.

1.10.4.5 Programming a Gas Compressibility Table

In the **ZTABL** option, you can enter data into a global table to define particular compressibility values. The GC868 can thus implement SonicWare® and other data tables to meet specific applications.

1. Press **[→]** and **[F1]** to enter the **ZTABL** option.
2. Press **[F1]** if you do not want to *Use Global Z-table*, or **[F2]** to program the table. (If you press **[F1]**, the GC868 returns to the **ADVAN** window.)
3. Use the numeric keys to enter the *Base Compressibility* of the gas, and press **[ENT]**.
4. Enter the number of desired *Pressure Columns*, from 1 to 10. Press **[ENT]**.
 - a. Enter the *Pressure Value* for Column 1. Press **[ENT]**.
 - b. Repeat step a for each succeeding column, until you have programmed all the desired columns.
5. Enter the number of desired *Temperature Rows*, from 1 to 10. Press **[ENT]**.
 - a. Enter the *Temperature Value* for Row 1. Press **[ENT]**.
 - b. Repeat step a for each succeeding row, until you have programmed all the desired rows.
6. Enter the *Z-Factor* for column 1, row 1 (1,1).
7. Repeat step 6 for each succeeding column, row location, until you have programmed the entire table.

The GC868 returns to the **ADVAN** window.

1.10.4.6 Setting Correlation Parameters

The **CORR** option allows you to adjust parameters for the Skan/Correlation technique in the **ACTIV** menu.

IMPORTANT: The **CORR** default settings are suitable for most applications. Before changing any of these parameters, consult the factory.

1. Press [→] and [F2] to enter the **CORR** option.
2. Use the [→] and [F1]-[F4] keys to select the desired *Signals per reading*, from 8 to 128. (The default is 8.)
3. Use the numeric keys to enter the desired *# Correlation Xmit Pulses*, from 1 to 16. Press [ENT].
4. Use the [→] and [F1]-[F4] keys to select the desired *Correlation Xmit Code*. The available choices include None, Code A, Code B, Code C and Code D.
5. Enter the value (from 0 to 250 μ sec) for the *C>S (Correlation>Skan) Switch*, and press [ENT].
6. Enter the *% of Peak (Correlation)* from -100 to 100%, and press [ENT].
7. Enter the *Minimum Peak % limit* from -100 to 100%, and press [ENT].
8. Enter the *Maximum Peak % limit* from -100 to 100%, and press [ENT].

The GC868 returns to the **ADVAN** window.

1.10.4.7 Setting Skan Parameters

In the **SKAN** option, you can activate and set parameters for a negative peak percent for both the Skan measurement technique (in the **ACTIV** submenu) and the Skan portion of the Skan/Measure technique. When negative peak percent is active, the GC868 searches for the maximum negative peak before the positive peak, and then calculates the T at both negative peak percents entered; these times are averaged for the T measurement.

IMPORTANT: The **SKAN** default settings are suitable for most applications. Before changing any of these parameters, consult the factory.

1. Press [→] and [F3] to enter the **SKAN** option.
2. Press [F1] if you do not want to *Use Negative Peak*, or [F2] to activate negative peak. (If you press [F1], the GC868 returns to the **ADVAN** window.)
3. Enter the *Minimum Negative Peak %* from -100 to -10%, and press [ENT].
4. Enter the *Maximum Negative Peak %* from -100 to -10%, and press [ENT].

The GC868 returns to the **ADVAN** window.

1.10.4.8 Synchronizing Meter Transmissions

The **TRANS** (Transmit) option appears only if an alarm card has been installed in the GC868. It allows the GC868 and its transducers to operate synchronously with another meter on the same flowcell. When triggered, the alarm card can close a relay when the other meter is transmitting, to prevent conflicting signals.

1. Press [→] and [F4] to enter the **TRANS** option.
2. Press [F1] if you do not want to activate the *Gate Alarm*, or [F2] to activate the alarm.

1.10.4.9 Procedure Options

After completing the above steps, the meter returns to the **ADVAN** prompt. Continue as follows:

- To continue programming the meter, refer to the menu maps in Appendix A and navigate to the desired menu. Then, proceed to the appropriate section of this manual for instructions.
- To leave the *User Program* and retain the previous settings, press [EXIT] twice and then press [F1] = **NO** at the *SAVE* prompt. Any programming changes will be discarded and you will be returned to the data display.

- To leave the *User Program* and return to measurement mode, press **[EXIT]** twice and then press **[F2] = YES** at the *SAVE* prompt. Your programming changes will be entered into the meter's memory, and you will be returned to the data display.

1.11 Setting the Clock

Use the **CLOCK** submenu to enter the current date and time. Refer to *Figure A-3 on page A-3*.

1.11.1 Setting the Date

1. To program the **CLOCK** submenu, press **[→]** and **[F2]** at the initial *User Program*.
2. The first prompt displays the programmed *Date*.
 - If the displayed date is correct, press **[F1] = OK** and proceed to step 2.
 - If the displayed date is incorrect, press **[F2] = EDIT** to change the date, and complete the steps below.
 - a. Enter the current *Year* and press **[ENT]**. The allowable range is 0 to 99.
 - b. Use the **[←]**, **[→]** and **[F1]-[F4]** keys to select the current *Month*.
 - c. Enter the current *Day* and press **[ENT]**. The allowable range is 1 to the number of days in the current month.

1.11.2 Setting the Time

3. The next prompt displays the programmed *Time*.
 - If the displayed time is correct, press **[F1] = OK** to return to the **User Program**.
 - If the displayed time is incorrect, press **[F2] = EDIT** to change the time, and complete the steps below.
 - a. Press **[F1] = AM** or **[F2] = PM**. Then enter the current *Hour* and press **[ENT]**. The allowable range is 1 to 12.

Note: *A time of 12 PM represents Noon and a time of 12 AM represents Midnight.*

- b. Enter the current *Minutes* and press **[ENT]**. The allowable range is 0 to 59.
- c. Enter the current *Seconds* and press **[ENT]**. The allowable range is 0 to 59.

1.11.2.1 Procedure Options

After completing the above steps, the meter returns to the *User Program*. Continue as follows:

- To continue programming the meter, refer to the menu maps in Appendix A and navigate to the desired menu. Then, proceed to the appropriate section of this manual for instructions.
- To leave the *User Program* and retain the previous settings, press **[EXIT]** and then press **[F1] = NO** at the *SAVE* prompt. Any programming changes will be discarded and you will be returned to the data display.
- To leave the *User Program* and return to measurement mode, press **[EXIT]** and then press **[F2] = YES** at the *SAVE* prompt. Your programming changes will be entered into the meter's memory, and you will be returned to the data display.

1.12 Setting Up Serial Communications

The Model GC868 flowmeter can transmit stored data and displayed readings to a remote ANSI terminal or a personal computer by connecting the meter's RS232 interface to the serial port of the PC. In addition, the Model GC868 can receive and execute remote commands via this link. The meter can also be configured with a MODBUS option card for MODBUS communications, a Foundation Fieldbus option card for Foundation Fieldbus communications, an Ethernet option card for Ethernet communications, or with a MODBUS/TCP option card for MODBUS communication over the Ethernet, if desired.

Note: *To set Fieldbus communications parameters, see Appendix D, Foundation Fieldbus Communications.*

Use the **COMM** submenu to set the RS232, MODBUS, Ethernet and MODBUS/TCP communications port parameters and to enter a network identification number. A network identification number is required to use the Panametrics *Instrument Data Manager* or *PanaView* software. While following the programming instructions, refer

to the menu map in Figure A-3 on page A-3. Enter the **COMM** submenu by pressing [→] and [F3] at the initial *User Program* screen and complete the following steps:

1. Use the [←] and [→] and [F1]-[F4] keys to select the desired *Baud Rate*. The available rates are 300, 600, 1200, 2400, 4800, 9600 and 19,200 baud.
2. Use the [←] and [→] and [F1]-[F4] keys to select the number of *UART Bits*, as listed in Table 1-8 below.

Table 1-8: UART Bits Options

Option Bar	# Data Bits	# Stop Bits	Parity
8,no	8	0	None
8,odd	8	0	Odd
8even	8	0	Even
7,odd	7	1	Odd
7even	7	1	Even

3. Enter a *Network ID* number between 1 and 254 and press [ENT]. The default number is 1.

A network ID number is only necessary for communication with the Panametrics *Instrument Data Manager* or *PanaView* software. See the software *User's Manual* for more information.

IMPORTANT: If the network ID number is changed, communication with the *Instrument Data Manager* or *PanaView* must be re-established with the new ID number.

1.12.1 Entering MODBUS Data

4. If your GC868 does not include an option card for MODBUS communications, you have completed programming the **COMM** submenu. However, if you have installed a MODBUS option card, complete the following steps:
 - a. Use the [F1]-[F3] keys to select the desired *MODBUS Baud Rate* from four selections: 2400, 4800, 9600 and 19200.
 - b. Use the [F1]-[F3] keys to select the desired *MODBUS Parity* from three selections: none, odd and even.
 - c. Press [F1] to select one *MODBUS Stop Bit*, or [F2] to select two stop bits.
 - d. Use the numeric keys to enter a *MODBUS Address* (from 1 to 247) and press [ENT].

Note: *If you change any of these MODBUS options, you will need to power down your meter and power up again to load the changes into the MODBUS option card.*

1.12.2 MODBUS/TCP Parameters

If your GC868 does not include an option card for MODBUS/TCP communications, you have completed programming the **COMM** submenu. However, if you have installed a MODBUS/TCP option card, you must complete the following steps:

1. Press [F3] to select the appropriate *MODBUS Baud Rate* of 9600.
2. Press [F1]-[F3] to set the *MODBUS Parity* as none, odd or even.
3. Press [F1] to select one *MODBUS Stop Bit*, or [F2] to select two stop bits.
4. Use the numeric keys to enter a *MODBUS Address* (from 1 to 247) and press [ENT].

Programming of the **COMM** submenu has now been completed. To leave the *User Program*, press [EXIT]. If changes have been made in any of the submenus, the **SAVE** screen (shown above) appears. Press [F1] to return to measurement mode without saving the file or press [F2] to enter the **SAVE** submenu and save the file.

- 1.12.2.1 Procedure Options** After completing the above steps, the meter returns to the *User Program*. Continue as follows:
- To continue programming the meter, refer to the menu maps in Appendix A and navigate to the desired menu. Then, proceed to the appropriate section of this manual for instructions.
 - To leave the *User Program* and retain the previous settings, press **[EXIT]** and then press **[F1] = NO** at the *SAVE* prompt. Any programming changes will be discarded and you will be returned to the data display.
 - To leave the *User Program* and return to measurement mode, press **[EXIT]** and then press **[F2] = YES** at the *SAVE* prompt. Your programming changes will be entered into the meter's memory, and you will be returned to the data display.

1.12.3 MODBUS Register Map When equipped with the optional MODBUS output card, the GC868 flow transmitter can send flow data and diagnostic information to a flow computer (or SCADA) serially, using a Gould-type RTU protocol. In this case, only the MODBUS function command, 3 (read multiple registers), 6 (write multiple registers) is valid. The format for the data exchange is as follows:

- The **send** command (initiated by the host flow computer or controller) comes in the form:
[time delimiter]<Addr><3><First Register MSB>
<First Register LSB><Register Count MSB>
<Register Count LSB><CRC Low><CRC High>[time delimiter]
- The response (initiated by the host flow computer or controller) comes in the form:
[time delimiter]<Addr><3><Byte count><Data.....>
<CRC Low><CRC High>[time delimiter]

The format for the returned data types is as follows:

- Integer (16 bit Integer) <MSB><LSB>
1 Register - 16 bit integer
- Integer (32 bit Integer) <MSB><LSB><LSB><LSB>
2 Register - 32 bit integer
- Floating Point (FP) <EXP><MAN><MAN><MAN>
2 Registers - 32 bit IEEE floating point number

To request specific parameters from the GC868 via the MODBUS, the control system must enter the appropriate register number. Only registers 1 through 90 are available for MODBUS communications, while registers 508 through 512 are used by the GC868 to store the MODBUS parameters. For details, see Table 1-9 on page 1-28.

Note: *If you request Ch2 or AVE data from a 1-Channel meter, the values will all be zero.*

Table 1-9: MODBUS Registers for a 1-Channel GC868

MODBUS Reg #	DPR Hex Addr	Description	Scaling (decimal places)	Size in Bytes
1	0	1" Clear Ch1 Totalizers"	--	2 (16 bit signed)
2	2	Not Used	--	2 (16 bit signed)
3	4	Velocity	2	4 (2 16-bit int)
5	8	Act Volumetric	#Q DIGITS	4 (IEEE 32 bit)
7	C	Std Volumetric	#Q DIGITS	4 (IEEE 32 bit)
9	10	Fwd Totals	#T DIGITS	4 (2 16 bit int)
11	14	Rev Totals	#T DIGITS	4 (2 16 bit int)
13	18	#Tot Digits	0	2
14	1A	Mass Flow	#M DIGITS	4 (IEEE 32 bit)

Table 1-9: MODBUS Registers for a 1-Channel GC868

MODBUS Reg #	DPR Hex Addr	Description	Scaling (decimal places)	Size in Bytes
16	1E	Fwd Mass Totals	#MT DIGITS	4 (2 16-bit int)
18	22	Rev Mass Totals	#MT DIGITS	4 (2 16-bit int)
20	26	#Mass Tot Digits	0	2
21	28	Timer	2	4 (2 16-bit int)
23	2C	Error Code	0	2
24	2E	Sound Speed	3	4 (2 16-bit int)
26	32	Density	4	4 (2 16-bit int)
28	36	Signal Strength Upstream	1	4 (2 16-bit int)
30	3A	Signal Strength Downstream	1	4 (2 16-bit int)
32	3E	Temperature	2	4 (2 16-bit int)
34	42	Pressure	3	4 (2 16-bit int)
508	3F6	² MODBUS baud rate	0	2
509	3F8	³ MODBUS parity	0	2
510	3FA	⁴ MODBUS stop bits	0	2
511	3FC	MODBUS meter addr	0	2
512	3FE	RESERVED	---	---

Notes:

- Clear Totalizers:**
flag from the 8051 to clear either the Channel 1 or Channel 2 totalizers.
- MODBUS baud rate:**
5 = 2400, 6 = 4800, 7 = 9600, 8=19,200
- MODBUS parity:**
0 = none, 1 = odd, 2 = even
- MODBUS stop bits:**
1 = 1 stop bit, 2 = 2 stop bits
- AVG Error Code:**
0=Both Ch1 and Ch2 are in error.
1=Ch1 only is in error
2=Ch2 only is in error
3=Both channels are error free

1.13 Saving Site Data

The currently programmed site data may be stored in the Model GC868's non-volatile memory by saving it as a site file. Up to ten site file names, consisting of up to five characters each, may be stored at any given time. While following the programming instructions, refer to Figure A-3 on page A-3 of Appendix A, *Menu Maps*. Enter the **SAVE** submenu by pressing [→] and [F4] at the initial *User Program* screen and complete the following steps:

- Enter a new site file name and press [ENT], or use the [←]. [→] and [F1]-[F4] keys to select and overwrite an existing site file.

Note: *The option bar will show only as many choices as there are existing site files.*

If ten site files are already stored in memory, an existing site file must be deleted before a new site file name can be assigned. See Chapter 5, *Clearing Data*, for details.

When a site file is stored in memory, it becomes the active site file until another site file is created or retrieved. (See the next section for instructions on retrieving a site file.) To verify that the site file has been saved, use the [↑] key to scroll back to the **SITE NAME** prompt and see if the name appears on the option bar (use the [←] and [→] keys to scroll through the list, if necessary). Whenever a new site file name is saved, it is automatically assigned to the next available function key. Press [EXIT] to leave the **SAVE** submenu.

- Use the [←] and [→] and [F1]-[F4] keys to select another menu, or press [EXIT] to leave the *User Program* and return to measurement mode.

1.14 Recalling a Site

Any site file currently stored in the Model GC868's non-volatile memory may be recalled at any time. Up to ten site file names, consisting of up to five characters each, may be stored at any given time. While following the programming instructions, see Figure A-3 on page A-3 of Appendix A, *Menu Maps*. Enter the **RECLL** submenu by pressing [→] twice and [F1] at the initial *User Program* screen and complete the following steps:

- Use the [←], [→] and [F1]-[F4] keys to select and recall an existing site file.

Note: *The option bar shows only as many choices as there are existing site files. The files are listed in chronological order by creation date.*

Upon recall, the selected site file becomes active and all of its programmed parameters become current.

IMPORTANT: The **CLOCK** and **I/O** data is not recalled with the site file, while the **SYSTEM** and **COMM** data is recalled with the site file.

Note: *If you have loaded a site file into a GC868, but the option cards are not in the same slots or programmed the same way as when the site file was first saved, the GC868 displays a warning to review slot information. This display does not mean that the option cards have lost their program information!*

- Use the [←] and [→] and [F1]-[F4] keys to select another menu, or press [EXIT] to leave the *User Program* and return to measurement mode.

1.15 Activating Security

In order to prevent unauthorized tampering with the flowmeter's programming, the Model GC868 is equipped with a security feature that locks out the following menus:

- Program Menu [PROG]
- Calibration Menu [CAL]
- Log Menu [LOG]
- Clear Menu [CLR]

When the system is locked, access to the above menus will be denied unless the correct password is entered. The Model GC868 is shipped with a *default password*, which is given later in this section. For increased security, the default password should be changed.

IMPORTANT: Once the system has been locked, it can only be unlocked by entering the password, because access to the **SECUR** submenu is restricted.

To program the **SECUR** submenu, press [→] twice and [F2] at the initial *User Program* screen. Refer to Figure A-3 on page A-3.

IMPORTANT: It is recommended that all program parameters be recorded before changing the password. (This information should be recorded in Appendix B, Data Records, as a matter of routine.) If the password is lost, the site data is not retrievable and will have to be re-entered.

1. At the *Lock Out* prompt, press **[F1] = UNlck** to unlock the system and return to the **Global PROGRAM** prompt, or press **[F2] = LOCK** to lock the system.

Note: *If the system was unlocked at the above prompt, the following three prompts do not appear.*

2. Enter the current *Password* (**2719** is the default password) and press **[ENT]**.
3. At the *?Edit Password* prompt, press **[F1] = NO** to leave the password unchanged and proceed to *Procedure Options* on the next page, or press **[F2] = YES** to enter a new password.

IMPORTANT: Since the default password is printed in this manual, a new password should be entered. If the password is ever lost, contact the factory for assistance.

4. Enter the *New Password* and press **[ENT]**. Any combination of letters and numbers up to a total of 21 characters may be used as a password.

Note: *Keep in mind that the password may have to be entered frequently from the keypad. A long and/or complex password may soon become annoying to use.*

5. *Verify* the *New Password* by entering it again and press **[ENT]**. Be sure to record the new password in a safe place.

1.15.1 Procedure Options

After completing the above steps, the meter returns to the *User Program* prompt. Continue as follows:

- To continue programming the meter, refer to the menu maps in Appendix A and navigate to the desired menu. Then, proceed to the appropriate section of this manual for instructions.
- To leave the *User Program* and retain the previous settings, press **[EXIT]** and then press **[F1] = NO** at the *SAVE* prompt. Any programming changes will be discarded and you will be returned to the data display.
- To leave the *User Program* and return to measurement mode, press **[EXIT]** and then press **[F2] = YES** at the *SAVE* prompt. Your programming changes will be entered into the meter's memory, and you will be returned to the data display.

Chapter 2. Displaying Data.

Introduction.....	2-1
The BIG Submenu	2-1
The DUAL Submenu.....	2-2
The GRAPH Submenu.....	2-3
The LOG Submenu.....	2-4
Displaying the Transducer Signal.....	2-7
Setting the LCD Backlight.....	2-10
Activating Sleep Mode.....	2-10

2.1 Introduction

This chapter explains how to display measurement data in various formats. Each of the two display screen panes may be programmed independently.

Note: *The instructions in this chapter assume that the left display pane is active. If the right display pane is active, simply change all [F1]-[F4] designations to [F5]-[F8].*

The following submenus are included in the *Display Menu*:

- **BIG** - displays a single measurement in large size text
- **DUAL** - permits the simultaneous display of two measurements, in the same screen pane, in standard size text
- **GRAPH** - displays a graph of either velocity or volumetric flow versus time
- **LOG** - displays the data stored in a log file either graphically or numerically
- **SIGNL** - graphically displays any one of five transducer signals versus time
- **BACKL** - sets the time that the LCD display backlight remains on before it is automatically turned off.
- **SLEEP** - blanks out the display screen until a key is pressed.

Refer to Figure A-5 on page 5 and proceed to the appropriate section to set up the Model GC868 display screen(s), using one of the listed submenus.

2.2 The BIG Submenu

The **BIG** format, which is the Model GC868's default power up format, displays one measurement in large print. To select the **BIG** format and the measurement to display in this format, follow the instructions in this section.

Upon power up, a standard measurement mode display (similar to the one shown below) appears. Press the appropriate side of the [**SCREEN**] key to activate the desired pane of the display screen, and complete the following steps:

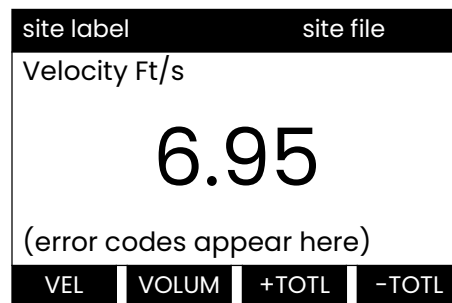

The default power up screen is already in **BIG** mode. If a different display mode is active, access the *Display Menu* by pressing the [**DISP**] key.

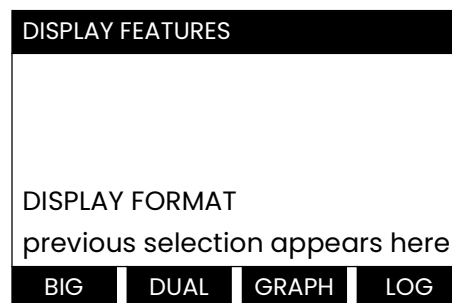

Press [**F1**] to select the **BIG** option. The measurement mode screen reappears with the display in the **BIG** format.

site label	site file
Velocity Ft/s	
6.95	
(error codes appear here)	
VEL	VOLUM +TOTL -TOTL

Use the **[F1]-[F4]**, **[←]** and **[→]** keys to select the desired display parameter option. See Table 2-1 below for a complete description of the available options.

Table 2-1: Measurement Parameter Options

Option Bar Choice	Description
[F1] = VEL	Flow Velocity
[F2] = VOLUM	Volumetric Flow
[F3] = +TOTL	Forward Totalized Volume Flow
[F4] = -TOTL	Reverse Totalized Volume Flow
[→] + [F1] = TIME	Total Flow Measurement Time
[→] + [F2] = MDOT	Mass Flow
[→] + [F3] = +MASS	Forward Totalized Mass Flow
[→] + [F4] = -MASS	Reverse Totalized Mass Flow
[→] + [←] + [F1] = DIAG	Diagnostic

Note: See Chapter 3, Operation, of the Startup Guide for more details on selecting a measurement parameter to display.

2.3 The DUAL Submenu

The **DUAL** format displays two measurements simultaneously in normal print. To select the **DUAL** format and the measurements to display in this format, follow the instructions in this section.

Upon power up, a standard measurement mode display (similar to the one shown below) appears in **BIG** format. Press the appropriate side of the **[SCREEN]** key to activate the desired pane of the display screen, and complete the following steps:

1. To access the *Display Menu*, press the **[DISP]** key.
2. Press **[F2]** = **DUAL**. The measurement mode display reappears and the display is now in the **DUAL** format.
3. Use the **[F1]-[F4]**, **[←]** and **[→]** keys to select the desired display parameter option. See Table 2-1 on page 2-2 for a complete description of the available options.

Note: See Chapter 3, Operation, of the Startup Guide for more details on selecting a measurement parameter to display.

With the **DUAL** format display screen active, when a measurement parameter is selected, the top line of the prompt area will be changed to show that parameter. The parameter previously displayed at the top of the display is moved to the bottom of the display, and the previous bottom parameter is no longer shown.

2.4 The GRAPH Submenu

2.4.1 Setting Up the GRAPH Format

The **GRAPH** submenu permits the display of either the flow velocity, mass flow or the volumetric flow on an XY bar graph, with a specified time interval on the x-axis. This section describes the procedures for setting up and using the graph format.

Press the appropriate side of the **[SCREEN]** key to activate the desired pane of the display screen, and complete the following steps:

1. To access the *Display Menu*, press the **[DISP]** key.
2. Press **[F3] = GRAPH**.
3. Press **[F1]-[F3]** to graph the *Flow Velocity*, *Volumetric Flow* or *Mass Flow*, respectively.
4. Use the **[←]**, **[→]** and **[F1]-[F4]** keys to select the desired *Time Increment*.
5. Enter a maximum value for the *Y-axis* (vertical) scale that is larger than the maximum expected reading and press **[ENT]**.
6. At the *Y Range* prompt, press **[F1]** to graph only positive Y values or press **[F2]** to graph both positive and negative Y values.

After the **Y RANGE** is entered, the Model GC868 automatically begins taking measurements and displays them in the specified graphical format. Proceed to the next section for a discussion of manipulating the graphical display.

2.4.2 Using the GRAPH Format

While viewing data in the **GRAPH** format, the function keys are programmed to permit a variety of actions. These options are described in detail below.

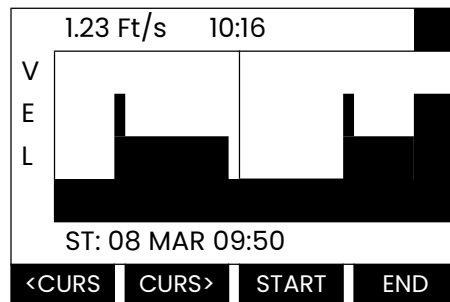

Use the **[←]**, **[→]** and **[F1]-[F4]** keys to select the desired option. See Table 2-2 on page 2-4 for a listing of the available choices.

At any given time, 120 data points will be shown on the **GRAPH** screen. The *cursor*, which is displayed as a vertical line that extends the full height of the graph window, can be used to select any one of these data points.

The typical screen shown above is for a *Velocity vs. Time* graph with only the positive y-axis displayed. The measurement parameter (**VEL**) is shown to the left of the y-axis and there is a *message line* below the graph that initially indicates the starting date and time of the graphed data. Notice that most of the locator bar has been replaced by a *status line* in standard video that shows the value, units and time of the measurement at the current cursor location. However, there is still an inverse video *pointer* at the far right of this line to indicate that additional option bar choices are available.

Note: *The date in the message line includes only the day and the month (not the year), and the times in the status line and the message line include only the hours and minutes (not the seconds).*

Because the times displayed in the **GRAPH** format are in whole minutes only, movement of the cursor may not result in a visible change in the posted times. For example, if a **TIME INCREMENT** of 30 seconds has been programmed, two presses of either cursor movement key will be required to change the displayed time by one minute.

Table 2-2: Graph Display Options

Option Bar Choice	Description
[F1] = <CURS	Moves the cursor to the left and displays the corresponding measurement value and time in the status line: (i.e. 6.85 Ft/s 10:38)
[F2] = CURS>	Moves the cursor to the right and displays the corresponding measurement value and time in the status line: (i.e. 5.31 Ft/s 10:38)
[F3] = START	Moves the cursor all the way to the left side of the graph and posts the starting date and time in the message line: (i.e. ST: 08 MAR 10:38)
[F4] = END	Moves the cursor all the way to the right side of the graph and posts the ending date and time in the message line: (i.e. END 08 MAR 11:14)
[→] + [F1] = YMAX	Displays the programmed maximum Y value in the message line: (i.e. YMAX 25.0 Ft/s)
[→] + [F2] = T INC	Displays the programmed time increment value in the message line: (i.e. T INC 30 seconds)
[→] + [F3] = EXIT	Leaves the GRAPH format and returns the display to the previous data format. (The [EXIT] key on the keypad will also perform this function.)

2.5 The LOG Submenu

The **LOG** submenu permits the display of the data in a log file either graphically or numerically. Although the Model GC868 can display all of the data in a log file, screen size limitations prevent the simultaneous display of the complete log file. Therefore, the function keys must be used to view the remaining data. Follow the instructions in this section to display a log file in the desired format.

2.5.1 Entering the LOG Submenu

Press the appropriate side of the **[SCREEN]** key to activate the desired pane of the display screen, and complete the following steps:

1. To access the *Display Menu*, press the **[DISP]** key.
2. Press **[F4] = LOG**.
3. Use the **[←]**, **[→]** and **[F1]–[F4]** keys to select the desired log file to display. At the **NAME** prompt, the option bar will show the names of all log files that are currently stored in memory. If there are no log files currently stored in memory, the following prompt will appear instead:

DISPLAY FEATURES
DISPLAY FORMAT
logging
All Logs Cleared!
hit key

There are no log files currently stored in memory. Either all of the log files have been cleared or no log files have yet been created. Press any key to return to measurement mode.

If the **All Logs Cleared!** prompt appears, at least one log file must be created and stored in memory before the *Display Log* function can be accessed. See Chapter 3, *Logging Data*, for instructions on creating a log file. After at least one log file is stored in memory and selected at the **NAME** prompt of the **LOG** submenu, proceed to the next step.

4. At the *Format* prompt, press **[F1]** to display the selected log in numeric format or press **[F2]** to display the selected log in graphical format.
 - If you pressed **[F1]**, go to the next page.
 - If you pressed **[F2]**, go to page 2-9.

2.5.2 Numeric Format

The Model GC868 can log up to three parameters simultaneously. Each set of data values is called a *record*, and up to 120 consecutive records can be stored in a *page*. A *log file* can consist of up to 120 pages. The numeric log display, which shows one record at a time, includes the following components:

- page number
- record number
- time and date of creation
- measurement value set
- error messages (if any)

Upon choosing **NUM** at the **FORMAT** prompt, the first record of the selected log file is displayed in a screen similar to the following:

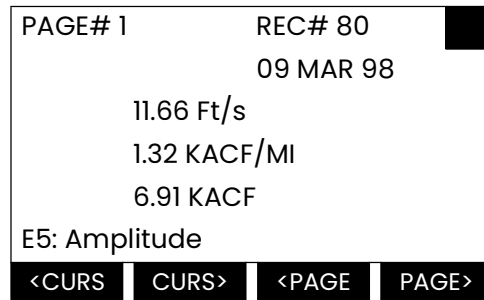

Use the **[←]**, **[→]** and **[F1]-[F4]** keys to view additional records or to exit the log display. The options are listed in Table 2-3 below.

In the numeric display screen, the locator bar (except for the inverse video pointer at the far right) is replaced by a standard video display of the page number and record number. The first line of the prompt area shows the time and date that the record was created, and the next three lines list the values for the three logged parameters. Finally, any error condition that existed at the time the record was taken is indicated by an error code in the bottom line of the prompt area.

Table 2-3: Numeric Log Display Options

Option Bar Choice	Description
[F1] = <CURS	display previous record on the current page
[F2] = CURS>	display the next record on the current page
[F3] = <PAGE	display the previous page
[F4] = PAGE>	display the next page
[→] + [F1] = START	display the first record on the current page
[→] + [F2] = END	display the last record on the current page
[→] + [F3] = EXIT	Leave the numeric LOG display and return to the previous data format. (The [EXIT] key on the keypad will also perform this function.)

2.5.3 Graphical Format

After choosing **PLOT** at the **FORMAT** prompt, the programming sequence continues as follows:

5. Enter a maximum value for the *Y-axis* (vertical) scale that is larger than the maximum expected reading. Press **[ENT]**.
6. At the *Y Range* prompt, press **[F1]** to graph only positive Y values or press **[F2]** to graph both positive and negative Y values.

After the **Y RANGE** is entered, the Model GC868 automatically displays the chosen log file records in the specified graphical format.

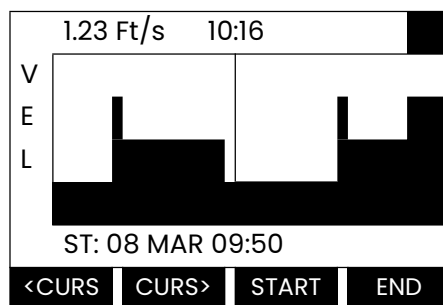

Use the **[←]**, **[→]** and **[F1]**-**[F4]** keys to select the desired option. The options are listed in Table 2-4 on page 2-6.

At any given time, the 120 records stored in one page of the log file will be graphed on the display screen. The *cursor*, which is shown as a vertical line that extends the full height of the graph window, can be used to highlight any one of these records.

IMPORTANT: Only the first of the three logged parameters is displayed in the graphical format of the **LOG** submenu. Therefore, when creating a log file, be sure to specify the parameter to be graphed at the **1st Value Logged** prompt. See Chapter 3, Logging Data, for details on creating a log file.

In the typical graphical display shown, the first logged parameter (**VEL**) is shown to the left of the *y-axis* and there is a *message line* below the graph that initially indicates the starting date and time of the current page. Notice that most of the locator bar has been replaced by a *status line* in standard video that shows the value, units and time of the record at the current cursor location. However, there is still an inverse video *pointer* at the far right of this line to indicate that additional option bar choices are available.

Note: *The date in the message line includes only the day and the month (not the year), and the times in the status line and the message line include only the hours and minutes (not the seconds).*

Because the times displayed in the **LOG** graph are in whole minutes only, movement of the cursor may not result in a visible change in the posted times. For example, if a **TIME INCREMENT** of 30 seconds has been programmed, two presses of either cursor movement key will be required to change the displayed time by one minute.

Table 2-4: Graphical Log Display Options

Option Bar Choice	Description
[F1] = <CURS	Move the cursor one record to the left and display the value and time of that record in the status line: (i.e. 6.85 Ft/s 10:38)
[F2] = CURS>	Move the cursor one record to the right and display the value and time of that record in the status line: (i.e. 5.31 Ft/s 10:38)
[F3] = <PAGE	Display the previous page of records

Table 2-4: Graphical Log Display Options (cont.)

Option Bar Choice	Description
[F4] = PAGE>	Display the next page of records
[→] + [F1] = START	Move the cursor to the first record on the current page and post the date and time of that record in the message line: (i.e. ST: 08 MAR 10:38)
[→] + [F2] = END	Move the cursor to the last record on the current page and post the date and time of that record in the message line: (i.e. END 08 MAR 11:14)
[→] + [F3] = YMAX	Display the programmed maximum Y value in the message line: (i.e. YMAX 25.0 Ft/s)
[→] + [F4] = T INC	Display the time increment value, as set when the log file was created, in the message line: (i.e. T INC 30 seconds)
[←] + [F1] = EXIT	Leave the graphical LOG display and return the display to the previous data format. (The [EXIT] key will also perform this function.)

2.6 Displaying the Transducer Signal

The **SIGNL** submenu permits the direct graphical display of several transducer signals. Specifically, the signals listed in Table 2-5 below may be viewed in this format.

Note: *Only one side of the display (either left or right) can show a signal at any given time.*

Table 2-5: Available Transducer Signals

Transducer Signal	Description
Skam Types	
Sup	upstream Skam signal
Sdown	downstream Skam signal
Cup	upstream Skam correlation
Cdown	downstream Skam correlation
Measure Types	
Mup	upstream Measure signal
Mdown	downstream Measure signal

Note: *The Measure type signals (Mup and Mdown) are only available if the S/M burst technique was selected in the **ACTIV** menu.*

Refer to Figure A-5 on page A-5 and complete the following steps to display the transducer signals. Press the appropriate side of the **[SCREEN]** key to activate the desired pane of the display screen, then proceed as follows:

Note: *For this discussion, it is assumed that the left pane of the display screen is active. If the right pane is active, it is only necessary to replace the **[F1]**-**[F4]** keys designations by the **[F5]**-**[F8]** keys.*

1. To access the *Display Menu*, press the **[DISP]** key.
2. Press **[→]** and **[F1] = SIGNL**.

3. Press **[F1]** to display the **Sk**an type signals or press **[F2]** to display the **Measure** type signals.

Note: *If the Skan burst technique was selected in the ACTIV menu, the Signal to Display prompt does not appear and the Measure type signals are not available. To access these signals, the S/M burst technique must be selected.*

The signal graph is a plot of signal amplitude (y-axis) vs. time in microseconds (x-axis). When the **SIGNL** display screen first appears, it may briefly remain blank. As soon as the signal is acquired, processed and loaded into the display memory, the graph will appear. A *cursor*, which is displayed as a vertical line that extends the full height of the graph window, is used to highlight any point in time along the x-axis.

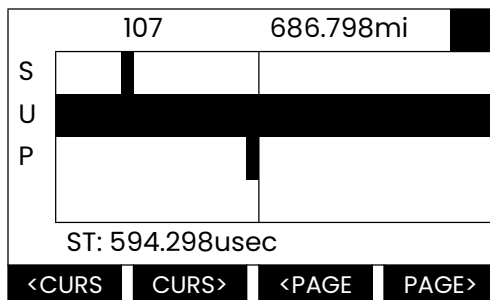

Use the **[←]**, **[→]** and **[F1]**-**[F4]** keys to select the desired option. The options are listed in Table 2-6 below.

The typical display screen shown has the **Sup** transducer signal listed to the left of the y-axis and there is a *message line* below the graph that initially indicates the starting date and time of the graphed signal. Notice that most of the locator bar has been replaced by a *status line* in standard video that shows the signal amplitude and the time (in microseconds) of the measurement at the current cursor location. However, there is still an inverse video *pointer* at the far right of this line to indicate that additional option bar choices are available.

Table 2-6: Graphical Log Display Options

Option Bar Choice	Description
[F1] = <CURS	Move the cursor to the left and display the amplitude and time in the status line: (i.e. 107 686.798mi)
[F2] = CURS>	Move the cursor to the right and display the amplitude and time in the status line: (i.e. 107 686.798mi)
[F3] = <PAGE	Display the previous page
[F4] = PAGE>	Display the next page
[→] + [F1] = START	Move the cursor to the start of the current page and post the starting date and time in the message line: (i.e. ST: 451.798usec)
[→] + [F2] = END	Move the cursor to the end of the current page and post the ending date and time in the message line: (i.e. END: 744.298usec)
[→] + [F3] = YMAX	Display the maximum Y value, which is set to 128 divisions in arbitrary units, in the message line.

Table 2-6: Graphical Log Display Options

Option Bar Choice	Description
[→] + [F4] = T INC	Display the time increment value in the message line. This is based on the frequency of the transducers and would equal 0.125 μsec for a 1 MHz transducer.
[←] + [F1] = EXIT	Leave the graphical SIGNL display and return the display to the previous data format. (The [EXIT] key on the keypad will also perform this function.)

In addition to the functions available on the option bar, some of the numeric keys are used to specify which transducer signal is displayed and to scale the resulting graph. Table 2-7 below lists these functions.

Table 2-7: Numeric Key Functions

Key	Function
1	Scroll down the transducer signal list
2	Scroll up the transducer signal list
4	Expand the graph vertically
5	Return expanded graph to previous size
7	Compress graph horizontally
8	Return compressed graph to previous size

In summary, three basic functions are performed with the numeric keys:

- **Signal Selection:** use the “1” and “2” keys to select a transducer signal for display by scrolling through the list of available signals.
- **Vertical Scaling:** The “4” and “5” keys are used to scale the graph vertically. Each press of the “4” key doubles the height of the graph, while each press of the “5” key halves the height of the graph. The three available scale factors are 1x, 2x and 4x.
- **Horizontal Scaling:** The “7” and “8” keys are used to scale the graph horizontally. Each press of the “7” key doubles the **T INC** value (2x horizontal compression), while each press of the “8” key halves the **T INC** value (2x horizontal expansion). The four available compression ratios are 1x, 2x, 4x and 8x.

To return to the standard data screen either select **EXIT** from the option bar or press the **[EXIT]** key on the keypad.

2.7 Setting the LCD Backlight

Use the **BACKL** submenu to specify the number of minutes the LCD display backlight remains on before it is automatically turned off. Press the appropriate side of the **[SCREEN]** key to activate the desired pane of the display screen, then proceed as follows:

Note: *For this discussion, it is assumed that the left pane of the display screen is active. If the right pane is active, replace the **[F1]**-**[F4]** keys designations by the **[F5]**-**[F8]** keys.*

1. To access the *Display Menu*, press the **[DISP]** key.
2. Press **[→]** and **[F2]** = **BACKL**.
3. Use the numeric keys to enter a value from 1 to 60 minutes and press **[ENT]**. To keep the backlight on constantly, enter a value of 0 and press **[ENT]**.

The Model GC868 will automatically return to the previous data display screen and the programmed backlight timeout interval will begin.

If no entries are made from the keypad before the backlight timeout interval expires, the backlight will automatically be turned off. At the next keypad entry, the backlight will be turned on and the specified timeout interval will begin again.

2.8 Activating Sleep Mode

During times when the display is not in use, use the **SLEEP** submenu to temporarily suspend LCD display activity, which allows the Model GC868 to process data more quickly. Press the appropriate side of the **[SCREEN]** key to activate the desired pane of the display screen, then proceed as follows:

Note: *For this discussion, it is assumed that the left pane of the display screen is active. If the right pane is active, replace the **[F1]**-**[F4]** keys designations by the **[F5]**-**[F8]** keys.*

1. To access the *Display Menu*, press the **[DISP]** key.
2. Press **[→]** and **[F3]** = **SLEEP**. The message "LCD SLEEP MODE -Press any key . . ." appears.
3. To reactivate the display and return to the previous data screen, press any key on the keypad. The Model GC868 will automatically return to the previous data display screen.

Note: *With **BIG** as the selected display format, exiting **SLEEP** mode may not erase the sleep mode message and the data screen will be superimposed on the message. If this occurs, simply enter the **DISP** menu and reselect the **BIG** format to refresh the screen. See the instructions earlier in this chapter.*

[no content intended for this page]

Chapter 3. Logging Data.

Introduction.....	3-1
Creating a Standard Log	3-2
Checking the Memory.....	3-5
Stopping a Log	3-5
Creating an ERROR Log	3-6

3.1 Introduction

This chapter explains how to use the Model GC868's data logging capability. The **LOG** menu, which is accessed by pressing the **[LOG]** key on the keypad, is divided into four submenus:

- **STD** - used to log up to three of the available measurement data parameters
- **MEM** - used to check the data logger memory to determine if the specified log will exceed the available memory
- **STOP** - used to terminate current data logging activity
- **ERROR** - used to log any generated error messages.

Up to twenty standard or error log files may be created and stored in battery-backed memory. Each log file contains up to three measurement parameters, the log start time and date, the log end time and date, the time interval between updates, and any error messages. Error logs record data only when an error message is generated.

The Model GC868 allocates up to 120 *pages* of memory, each of which can contain up to 120 *records*, for data logging. Each page is assigned a *header*, to distinguish one page from another. The header contains the log title, start date and time, end date and time, and the time increment. Each record contains the date and time of the measurement and the values for the three logged parameters.

Note: *Each log file uses at least one page of memory, and the same page can not be shared by two different logs.*

Since a fixed amount of memory is allocated for data logging, the number of active logs, the log time increments, and the length of the log runs will all affect how much memory is available for additional logging. For example, a log that updates every 5 seconds will use more memory than a log that updates every 6 minutes, assuming that they both run for the same length of time.

After a log file has been created, it may be displayed, printed, cleared or uploaded to a personal computer. Refer to the appropriate chapters of this manual for specific instructions.

Refer to Figure A-7 on page A-7 and proceed to the appropriate section for the desired **LOG** submenu. Each submenu may be followed in the sequence shown or the **[↑]** and **[↓]** keys may be used to scroll through the prompts.

3.2 Creating a Standard Log

Use the **STD** submenu to create a new standard log and to select the parameters to log, the log start time and date, the log end time and date, and the time increment. Also, any log file already stored in memory may be inspected and/or changed.

Press the appropriate side of the **[SCREEN]** key to activate the desired pane of the display screen, and complete the following steps:

1. To access the *Log Menu*, press the **[LOG]** key.
 - a. If you have activated the security feature (see Chapter 1, *Programming Site Data*, page 1-30 for details), enter the assigned password and press **[ENT]**.
2. Press **[F1] = STD**.
3. Use the **[←]**, **[→]** and **[F1]-[F4]** keys to inspect a completed log or to change an active log, or enter a new name (up to 5 characters) and press **[ENT]** to create a new log file.

Note: At the **NAME** prompt, the option bar will show the names of all completed or active log files that are currently stored in memory. Recall that a flashing asterisk (*) appears at the far right of the locator bar if the Model GC868 is currently logging data (see Chapter 3, *Operation, of the Startup Guide*).

4. At the *Log Message* prompt, enter a brief description (up to 21 characters) of the log. Press **[ENT]**.
5. Use the **[←]**, **[→]** and **[F1]-[F4]** keys to select the first parameter to be logged. See Table 3-1 below for a list of the available options.

IMPORTANT: Only the first parameter logged may be graphically displayed in the **LOG** Submenu of the Display Menu. Keep this in mind when selecting a parameter. See Chapter 2, *Displaying Data*, for instructions.

Table 3-1: Measurement Parameter Options

Option Bar Choice	Description
[F1] = VEL	Flow Velocity
[F2] = VOLUM	Volumetric Flow
[F3] = +TOTL	Forward Totalized Volume Flow
[F4] = -TOTL	Reverse Totalized Volume Flow
[→] + [F1] = MDOT	Mass Flow
[→] + [F2] = +MASS	Forward Totalized Mass Flow
[→] + [F3] = -MASS	Reverse Totalized Mass Flow
[→] + [F4] = DIAG	Diagnostic

Refer to Chapter 3, *Diagnostics*, of the *Service Manual* for a discussion of the many parameters accessible via the **DIAG** option.

Note: The units assigned to the parameters in Table 3-1 on page 3-2 are those selected in the User Program (**SYSTM** submenu).

6. Use the **[←]**, **[→]** and **[F1]-[F4]** keys to select the second parameter to be logged.
7. Use the **[←]**, **[→]** and **[F1]-[F4]** keys to select the third parameter to be logged.
 - If you selected a totalized value for display, go to step 8.
 - If you did not, go to step 9.
8. At the *Set Log Totals to 0* prompt, press **[F1]** to leave the log totals at their present value or press **[F2]** to reset the log totals to zero. Choosing **YES** at this prompt only resets the log totals to zero and has no effect on the meter totals.

3.2.1 Log Type

9. Press **[F1]** to create a non-circular log or press **[F2]** to create a circular log.

A non-circular log automatically stops when the meter runs out of memory or the specified **END TIME** is reached. A circular log runs continuously until manually stopped, but only the data from the most recent log cycle is saved. At the start of each cycle, the oldest recorded data is overwritten by the new data from the current cycle.



CAUTION! If data from one circular log cycle exceeds the meter's memory capacity, the earliest logged data will be lost.

3.2.2 STARTTIME Prompt

10. Press **[F1]** to accept the displayed start time or press **[F2]** to enter a different start time. To start logging immediately, press **[F3]**.
- If **OK** was selected, proceed to step 11.
 - If **NOW** was selected, proceed to step 12 if you selected a the non-circular log or to step 14 for a circular log.
 - If **EDIT** was selected, complete the steps listed on the next page.
 - a. Press **[F1]**-**[F2]** to select **AM** or **PM**. Then, enter the desired *Hour* (1-12) and press **[ENT]**. (Entry of a start time earlier than the current time will generate an error message.)
 - b. Enter the desired *Minutes* and press **[ENT]**. The acceptable range is 0 to 59.
 - c. Enter the desired *Seconds* and press **[ENT]**. The acceptable range is 0 to 59.

3.2.3 START DATE Prompt

11. Press **[F1]** to accept the displayed *Start Date* or press **[F2]** to enter a different start date. To start logging today, press **[F3]**.
- If **OK** or **TODAY** was selected, proceed to step 12 for a non-circular log or to step 13 for a circular log.
 - Otherwise, complete the following steps to *Edit* the Start Date.
 - a. Enter the desired *Year* and press **[ENT]**. The acceptable range is 0 to 99.
 - b. Use the **[←]**, **[→]** and **[F1]**-**[F4]** keys to select the desired *Month*.
 - c. Enter the desired *Day* and press **[ENT]**. The acceptable range is 1 to the number of days in the selected month (28, 29, 30 or 31).

3.2.4 END TIME Prompt

12. Press **[F1]** to accept the displayed *End Time* or press **[F2]** to enter a different end time. To select a specific time period for the log to run, press **[F3]**.
- If **OK** was selected, proceed to the **END DATE** prompt.
 - If **TIMED** was selected, proceed to the **LOG TIME** prompt.
 - If **EDIT** was selected, complete the steps on the next page.

Note: *The log END TIME must exceed the log START TIME by at least five minutes. Failure to observe this restriction will result in an error message.*

- a. Press **[F1]**-**[F2]** to select **AM** or **PM**. Then, enter the desired *Hour* (1-12) and press **[ENT]**. (Entry of a start time earlier than the current time will generate an error message.)
- b. Enter the desired *Minutes* and press **[ENT]**. The acceptable range is 0 to 59.
- c. Enter the desired *Seconds* and press **[ENT]**. The acceptable range is 0 to 59.

- 3.2.5 END DATE Prompt**
13. Press **[F1]** to accept the displayed end date or press **[F2]** to enter a different end date. To end the log today, press **[F3]**.
- If **OK** or **TODAY** was selected, proceed to the **TIME INCREMENT** prompt. Refer to Figure A-7 on page A-7 for a flow diagram of the programming sequences.
 - Otherwise, complete the steps below.
 - a. Enter the desired *Year* and press **[ENT]**. The acceptable range is 0 to 99.
 - b. Use the **[←]**, **[→]** and **[F1]-[F4]** keys to select the desired *Month*.
 - c. Enter the desired *Day* and press **[ENT]**. The acceptable range is 1 to the number of days in the selected month (28, 29, 30 or 31). The program proceeds to step 15.

3.2.6 DURATION Prompt If a circular log was specified, the programming sequence continues here after the log start time and/or start date is entered.

14. Press **[F1]** and enter a log duration in hours or press **[F2]** and enter a log duration in days. When the desired value has been entered, press **[ENT]**. The program proceeds to step 16.

3.2.7 LOG TIME Prompt If **TIMED** was selected at step 12, the programming sequence continues here.

15. Use the **[←]**, **[→]** and **[F1]-[F4]** keys to select the desired log duration. The available options are: 10min, 30min, 60min, 3 HR, 6 HR, 12 HR and 24 HR.

3.2.8 TIME INCREMENT Prompt Regardless of which of the various options were selected during the previous programming steps, all of the paths converge at this point.

16. Use the **[←]**, **[→]** and **[F1]-[F4]** keys to select the desired *Time Increment*. The available options are: 5sec, 10sec, 30sec, 1min, 3min, 6min, 12min, 30min and 60 min.

The time increment is the frequency at which the Model GC868 takes and records data measurements. If any reading takes longer than the programmed time increment, the log is filled in with the next consecutive reading. For example, assume that a velocity value of 3 ft/sec is recorded at 12:00:00 in a log with a time increment of five seconds. If the next reading is 8 ft/sec and it takes the meter 12 seconds to read this value, then both of the missed readings (12:00:05 and 12:00:10) will be filled in with the 8 ft/sec value.

3.2.8.1 Procedure Options You have completed entering data for a standard log. You can now do one of the following:

- Use **[↑]** and **[↓]** to review the previous menu prompts.
- Press **[F1]-[F4]** to select one of the **LOG** submenus.
- To return to the data screen and begin logging data, press the **[ENT]** key.

Although each log is restricted to only three logged parameters, it is still possible to log more than three parameters. Simply re-enter the **STD** submenu as many times as necessary to set up additional logs. Select the other desired parameters, and run these logs simultaneously with the first log.

3.3 Checking the Memory

Use the **MEM** submenu to verify that the available log memory is sufficient for the desired log. If the expected amount of logged data will exceed the remaining memory capacity, the Model GC868 suggests that some old logs be cleared to make room for the new log.

Press the appropriate side of the **[SCREEN]** key to activate the desired pane of the display screen, and complete the following steps:

1. To access the *Log Menu*, press the **[LOG]** key.
 - a. If you have activated the security feature (see Chapter 1, *Programming Site Data*, page 1-30 for details), enter the assigned password and press **[ENT]**.
2. Press **[F2] = MEM**.
3. After noting the information, press **[ENT]** to return to the main *Log Menu* screen.

The **MEM** screen lists the number of remaining unused memory pages out of the total number of 120 available pages. Also, the number of pages expected to be used by all currently programmed logs is given. If the number of pending pages exceeds the number of free pages, additional memory may be made available by clearing some old logs (see Chapter 5, *Clearing Data*).

If it is undesirable to delete old logs to free up additional memory, the number of pages pending may be reduced by altering the parameters of one or more of the currently active logs. For example, either increasing the time increment or decreasing the total logging time will reduce the memory requirements for a log file. Use the following equations to calculate the number of pages used by a log:

$$\text{number of records} = \frac{\text{length of log}}{\text{time increment}}$$

$$\text{number of pages} = \frac{\text{number of records}}{120}$$

Consider a log that is set to run for 24 hours with a time increment of 3 minutes. From Equation 3-1, the number of records = $(24 \times 60)/3 = 480$ records. Then, from Equation 3-2 above, the number of pages = $480/120 = 4$ pages. Thus, at least four pages of memory must be available for this log to run to completion. Notice that increasing the time increment to 6 minutes or decreasing the length of the log to 12 hours would reduce the memory requirement to only 2 pages.

3.4 Stopping a Log

Use the **STOP** submenu to terminate a logging process that is currently active. Press the appropriate side of the **[SCREEN]** key to activate the desired pane of the display screen, and complete the following steps:

1. To access the *Log Menu*, press the **[LOG]** key.
 - a. If you have activated the security feature (see Chapter 1, *Programming Site Data*, page 1-30 for details), enter the assigned password and press **[ENT]**.

Note: *Once a log is stopped it cannot be restarted, but the log remains in memory. To clear the log from memory, refer to Chapter 5, Clearing Data, for instructions.*

2. Press **[F3] = STOP**.
3. Use the **[←]**, **[→]** and **[F1]-[F4]** keys to select a log file to stop.

Note: *At the **NAME** prompt, the option bar will show the names of all completed or active log files that are currently stored in memory. Recall that a flashing asterisk (*) appears at the far right of the locator bar if the Model GC868 is currently logging data (see Chapter 3, Operation, of the Startup Guide).*

4. Press **[F1]** to continue logging and return to the initial *Log Menu* screen. Press **[F2]** to stop logging and return to the initial *Log Menu* screen.

3.4.1 Procedure Options

- Do one of the following:
- Press **[F1]-[F4]** to enter another **LOG** submenu.
 - Press **[EXIT]** to return to the data screen.

3.5 Creating an ERROR Log

Use the **ERROR** submenu to create a new error log and to select the logging parameters. An error log updates every 5 seconds (when the display updates), but only if a new error condition occurs. Error logs have a fixed length of 2 pages and contain sixty records per page. Each record shows the time of the error, the measurement parameter values at that time, and the error code message. The logged values of the chosen measurement parameters at the time of the error condition provide valuable troubleshooting information.

Press the appropriate side of the **[SCREEN]** key to activate the desired pane of the display screen, and complete the following steps:

1. To access the *Log Menu*, press the **[LOG]** key.
 - a. If you have activated the security feature (see Chapter 1, *Programming Site Data*, page 1-30 for details), enter the assigned password and press **[ENT]**.
2. Press **[F4] = ERROR**.
3. Use the **[←]**, **[→]** and **[F1]-[F4]** keys to inspect a completed log or to change an active log, or enter a new *Name* (up to 5 characters) and press **[ENT]** to create a new log file.

Note: *The option bar lists all error logs currently stored in memory. Recall that a flashing asterisk (*) appears at the far right of the locator bar if the Model GC868 is currently logging data (see Chapter 3, Operation, of the Startup Guide).*

4. At the Log Message prompt, enter a brief description (up to 21 characters) of the log. Press **[ENT]**.
5. Use the **[←]**, **[→]** and **[F1]-[F4]** keys to select the first parameter to be logged. See Table 3-2 below for a list of the available options.

IMPORTANT: Only the first parameter logged may be graphically displayed (see Chapter 2, *Displaying Data*).

Table 3-2: Measurement Parameter Options

Option Bar Choice	Description
[F1] = VEL	Flow Velocity
[F2] = VOLUM	Volumetric Flow
[F3] = +TOTL	Forward Totalized Volume Flow
[F4] = -TOTL	Reverse Totalized Volume Flow
[→] + [F1] = MDOT	Mass Flow
[→] + [F2] = +MASS	Forward Totalized Mass Flow
[→] + [F3] = -MASS	Reverse Totalized Mass Flow
[→] + [F4] = DIAG	Diagnostic

In addition, refer to Chapter 3, *Diagnostics*, of the *Service Manual* for a discussion of the many parameters accessible via the **DIAG** option.

Note: *The units assigned to the parameters in Table 3-2 on page 3-6 are those selected in the User Program (SYSTEM submenu).*

6. Use the **[←]**, **[→]** and **[F1]-[F4]** keys to select the second parameter to be logged.

3.5.1 Log Type

7. Use the [←], [→] and [F1]-[F4] keys to select the third parameter to be logged.
 - If you selected a totalized value for display, go to step 8.
 - If you did not, go to step 9.
8. At the *Set Log Totals to 0* prompt, press [F1] to leave the log totals at their present value or press [F2] to reset the log totals to zero. Choosing **YES** at this prompt only resets the log totals to zero and has no effect on the meter totals.
9. Press [F1] to create a non-circular log or press [F2] to create a circular log.

A non-circular log automatically stops when the meter runs out of memory or the specified **END TIME** is reached. A circular log runs continuously until manually stopped, but only the data from the most recent log cycle is saved. At the start of each cycle, the oldest recorded data is overwritten by the new data from the current cycle.



CAUTION! If data from one circular log cycle exceeds the meter's memory capacity, the earliest logged data will be lost.

3.5.2 STARTTIME Prompt

10. Press [F1] to accept the displayed start time or press [F2] to enter a different start time. To start logging immediately, press [F3].
 - If **OK** was selected, proceed to step 11.
 - If **NOW** was selected, you have finished setting up the error log. Proceed to *Procedure Options* on the next page.
 - If **EDIT** was selected, complete the steps listed on the next page.
 - a. Press [F1]-[F2] to select **AM** or **PM**. Then, enter the desired *Hour* (1-12) and press [ENT]. (Entry of a start time earlier than the current time will generate an error message.)
 - b. Enter the desired *Minutes* and press [ENT]. The acceptable range is 0 to 59.
 - c. Enter the desired *Seconds* and press [ENT]. The acceptable range is 0 to 59.

3.5.3 START DATE Prompt

11. Press [F1] to accept the displayed *Start Date* or press [F2] to enter a different start date. To start logging today, press [F3].
 - If **OK** or **TODAY** was selected, you have finished setting up the error log. Proceed to *Procedure Options* below.
 - Otherwise, complete the following steps to *Edit* the Start Date.
 - a. Enter the desired *Year* and press [ENT]. The acceptable range is 0 to 99.
 - b. Use the [←], [→] and [F1]-[F4] keys to select the desired *Month*.
 - c. Enter the desired *Day* and press [ENT]. The acceptable range is 1 to the number of days in the selected month (28, 29, 30 or 31).

3.5.3.1 Procedure Options

You have completed setting up the error log. Do one of the following:

- Use [↑] and [↓] to review the previous menu prompts.
- Press [F1]-[F4] to select one of the **LOG** submenus.
- To return to the data screen and begin logging data, press the [ENT] key. The * on the locator bar indicates that the Model GC868 is now compiling the specified error log.

The error log will continue to run until it is manually stopped, the meter runs out of memory (for a non-circular log), or the entire 120 records (2 pages x 60 records/page) have been logged.

Chapter 4. Printing Data

Introduction.....	4-1
Print Live Data.....	4-1
Printing Logs.....	4-4
Print Site File.....	4-6
Stop Printing.....	4-7
Setting Up a Printer.....	4-7
Printing Signal Array Data.....	4-8
Printing RTD Data.....	4-9

4.1 Introduction

The Model GC868 flowmeter has the capability to print any of the data stored in its memory via the built-in RS232 communications port. In order to use the function, the RS232 port must be connected to a printer with a serial port input. A printer with a parallel port input may be used with a third-party serial-to-parallel adapter.

Note: See Chapter 1, Installation, of the Startup Guide for instructions on wiring the RS232 port. For additional information, refer to Chapter 6, Serial Communications.

After connecting the Model GC868 to a printer, the *Print Menu* is used to print live or logged data in either numeric or graphical format. In addition, any site files stored in memory may be printed. The *Print Menu* is divided into the following submenus:

- **DATA** - use to print live data in numeric or graphical format
- **LOG** - use to print a log file in numeric or graphical format
- **PROG** - use to print a site file
- **STOP** - use to terminate any active print jobs
- **PRNTR** - use to specify the printer currently connected
- **SGNLS** - use to print transducer signal array data
- **RTDs** - use to send the numeric point value of a connected RTD device to the RS232 port.

For purposes of this discussion it is assumed that the left pane of the data display screen is active. If the right pane of the data display screen is active, all of the instructions remain the same, except that any references to the [F1]-[F4] keys should be replaced by the [F5]-[F8] keys.

Refer to Figure A-6 on page A-6 and proceed to the desired section for detailed instructions. As an additional aid, the relevant portion of the full menu map is reproduced in each section of this chapter. Any submenu may be followed in the sequence shown or the [↑] and [↓] keys may be used to scroll through the prompts.

Note: If a printer has not yet been set up, the instructions in "The PRNTR Submenu" must be completed before proceeding to any of the other submenus.

4.2 Print Live Data

Use the **DATA** submenu to print live measurement data, as it is collected. The data may be printed in either numeric or graphical format, with a user specified time increment.

IMPORTANT: Make sure that a printer has been properly set up before proceeding with this section.

To print live measurement data, refer to Figure A-5 on page A-5 and complete the following steps:

1. To access the *Print Menu*, press the [PRNT] key.

Note: The *Print Menu* is not protected by the security feature and a password is never required to access this menu.

2. Press [F1] to select the **DATA** option.
3. Press [F1] = **NUM** to print the data in numeric format or press [F2] = **PLOT** to print the data in graphical format.
 - If you press [F1], go to step 4.
 - If you press [F2], go to step 8.

4.2.1 Numeric Format

- Use the [←], [→] and [F1]-[F4] keys to select the first parameter to be printed. See Table 4-1 below for a list of the available options.

Table 4-1: Measurement Parameter Options

Option Bar Choice	Description
[F1] = VEL	Flow Velocity
[F2] = VOLUM	Volumetric Flow
[F3] = +TOTL	Forward Totalized Volume Flow
[F4] = -TOTL	Reverse Totalized Volume Flow
[→] + [F1] = MDOT	Mass Flow
[→] + [F2] = +MASS	Forward Totalized Mass Flow
[→] + [F3] = -MASS	Reverse Totalized Mass Flow
[→] + [F4] = DIAG	Diagnostic

Refer to Chapter 3, *Diagnostics*, of the *Service Manual* for a discussion of the many parameters accessible via the **DIAG** option.

Note: *The units assigned to the parameters in Table 4-1 above are those selected in the User Program (SYSTM submenu).*

- Use the [←], [→] and [F1]-[F4] keys to select the second parameter to be printed.
- Use the [←], [→] and [F1]-[F4] keys to select the third parameter to be printed.
- Use the [←], [→] and [F1]-[F4] keys to select the desired time increment (the frequency at which measurements are taken). The available options are: 5sec, 10sec, 30sec, 1min, 3min, 6min and 12min.

After the time increment is chosen, the Model GC868 returns to the standard data display screen and continues to take measurements. The live data is printed at the specified time intervals, until a **STOP** command is issued (see the instructions for the **STOP** submenu). A portion of a typical printout is shown in Figure 4-1 below.

```

DATA_DUMP OF (SITE NAME)
Channel LABEL  Channel MESSAGE

Start Date           20 OCT 97
Start Time           03:08:40 PM

                CH1      CH1      CH1
                VOLUM    +TOTL    SNDSP
HH:MM:SS           ACF/HR    ACF      FT/S

03:08:40 P    686.85    218.92    1039.147
03:08:50 P    666.71    220.83    1039.003
03:09:00 P    662.28    222.70    1039.511
03:09:10 P    675.59    224.84    1039.509
03:09:20 P    669.79    226.71    1039.470
03:09:30 P    675.99    228.58    1039.137
03:09:40 P    670.70    230.45    1039.105
03:09:50 P    684.00    232.57    1039.082
03:10:00 P    680.58    234.46    1039.255
03:10:10 P    678.12    236.34    1038.860

      :           :           :           :
      .           .           .           .

```

Figure 4-1: Typical Numeric Printout

4.2.2 Graphical Format

To print live data in graphical format, continue as follows:

- Use the [←], [→] and [F1]–[F4] keys to select the first parameter to be printed. See Table 4-2 on page 4-3 for a list of the available options.

Table 4-2: Measurement Parameter Options

Option Bar Choice	Description
[F1] = VEL	Flow Velocity
[F2] = VOLUM	Volumetric Flow
[F3] = +TOTL	Forward Totalized Volume Flow
[F4] = -TOTL	Reverse Totalized Volume Flow
[→] + [F1] = MDOT	Mass Flow
[→] + [F2] = +MASS	Forward Totalized Mass Flow
[→] + [F3] = -MASS	Reverse Totalized Mass Flow
[→] + [F4] = DIAG	Diagnostic

Refer to Chapter 3, *Diagnostics*, of the *Service Manual* for a discussion of the many parameters accessible via the **DIAG** option.

Note: *The units assigned to the parameters in Table 4-2 above are those selected in the User Program (SYSTEM submenu).*

- Enter the desired maximum value for the Y (vertical) axis and press [ENT].

Note: *Enter a Y AXIS MAX value that is larger than the largest expected measurement value.*

10. At the *Y Range* prompt, press **[F1]** to show only the positive Y axis or press **[F2]** to display both the positive and negative y axis.
11. Use the **[←]**, **[→]** and **[F1]-[F4]** keys to select the desired *Time Increment* (the frequency at which measurements are taken). The available options are: 5sec, 10sec, 30sec, 1min, 3min, 6min and 12min.

After the time increment is chosen, the Model GC868 returns to the standard data display screen and continues to take measurements. The live data is printed at the specified time intervals, until a **STOP** command is issued (see the instructions for the **STOP** submenu). A portion of a typical printout is shown in Figure 4-2 below.

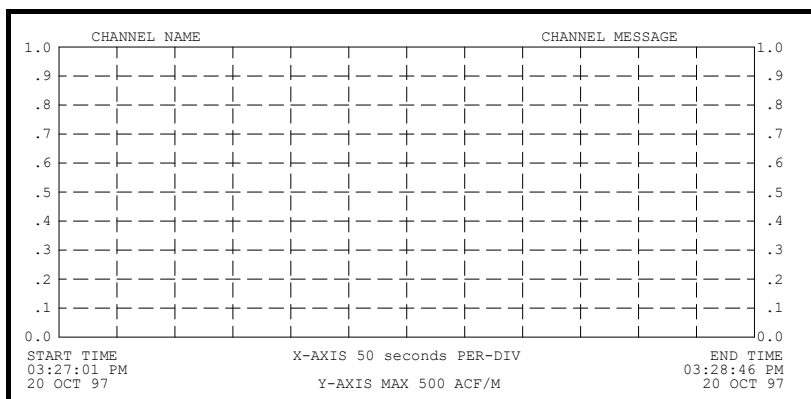

Figure 4-2: Typical Graphical Printout

4.3 Printing Logs

Use the **LOG** submenu to print logged measurement data, from a log file in the meter's memory. The data may be printed in either numeric or graphical format, with a user specified time increment.

IMPORTANT: Make sure that a printer has been properly set up before proceeding with this section.

To print logged measurement data, refer to Figure A-6 on page A-6 and complete the following steps:

1. To access the *Print Menu*, press the **[PRNT]** key.

Note: *The Print Menu is not protected by the security feature and a password is never required to access this menu.*

2. Press **[F2] = LOG**.
3. At the *Format* prompt, press **[F1]** to print the log in numeric format or press **[F2]** to print the log in graphical format.
4. Use the **[←]**, **[→]** and **[F1]-[F4]** keys to select a log file to print.

Note: *At the NAME prompt, the option bar shows the names of all completed or active log files currently stored in memory. If an active log is selected for printing, only the data already accumulated at the time of the print command will be printed.*

5. Enter the number of the *First Page* of the log to print and press **[ENT]**. (This prompt does not appear if the log file is only one page long.)
6. Enter the total number of log *pages* to print and press **[ENT]**. (This prompt does not appear if the log file is only one page long.)
 - If you chose **[F1] (Numeric)** at step 3, see the section below.
 - If you chose **[F2] (Graphic)** at step 3, go to the next page.

4.3.1 Numeric Format

After the numeric format (and starting page and number of pages, if applicable) is chosen, the Model GC868 returns to the standard data display screen and begins printing the log file. The printout continues until the entire log has been printed or until a **STOP** command is issued (see the instructions for the **STOP** submenu). A portion of a typical printout is shown in Figure 4-3 below.

LOG DUMP			
LOG NAME	Page# 1		
LOG MESSAGE			
Start Date	09 SEP 97		
Start Time	11:50:43 AM		
End Date	09 SEP 97		
End Time	11:54:45 PM		
	Ch1	Ch1	Ch2
	VOLUM	+TOTL	SNDSP
HH:MM:SS	ACF/HR	ACF	FT/S
11:50:45 A	686.85	218.92	1039.147
11:50:55 A	666.71	220.83	1039.003
11:51:05 A	662.28	222.70	1039.511

Figure 4-3: Typical Numeric Printout

4.3.2 Graphical Format

After the graphical format (and starting page and number of pages, if applicable) is chosen, complete the following additional steps:

7. Enter the desired maximum value for the *Y* (vertical) axis and press **[ENT]**.

Note: Enter a **Y AXIS MAX** value that is larger than the largest logged measurement value.

8. At the *Y Range* prompt, press **[F1]** to show only the positive *Y* axis or press **[F2]** to display both the positive and negative *y* axis.

The Model GC868 returns to the standard data display screen and begins printing the log file. The printout continues until the entire log has been printed or until a **STOP** command is issued (see the instructions for the **STOP** submenu). A typical printout is shown in Figure 4-4 below.

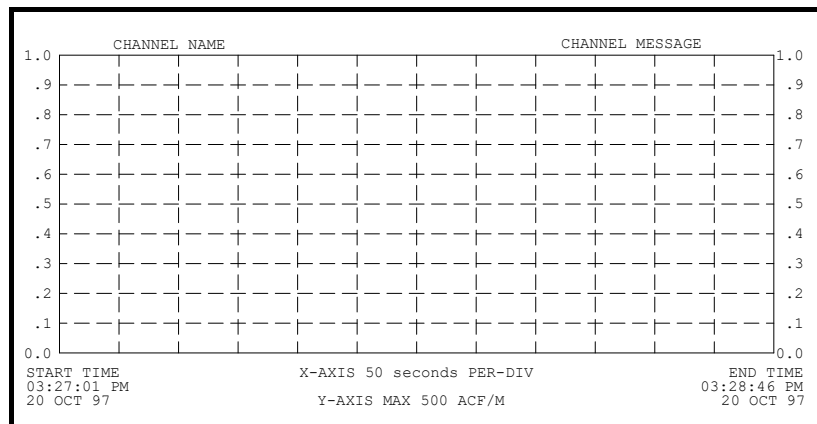

Figure 4-4: Typical Graphical Printout

4.4 Print Site File

Use the **PROG** submenu to print the data in a site file that was set up and saved as described in Chapter 1, *Programming Site Data*. To print a site file, refer to Figure A-6 on page A-6 and complete the following steps:

IMPORTANT: Make sure that a printer has been properly set up before proceeding with this section.

1. To access the *Print Menu*, press the **[PRNT]** key.

Note: *The Print Menu is not protected by the security feature and a password is never required to access this menu.*

2. Press **[F3] = PROG**.

3. Use the **[←]**, **[→]** and **[F1]-[F4]** keys to select the desired *Site File* to print.

Note: *All site files currently in memory appear on the option bar. The active site file is always listed as the first choice (**Work**).*

The Model GC868 returns to the standard data display screen and generates a site file printout similar to the one shown in Figure 4-5 below. The printout continues until the entire file has been printed or until a **STOP** command is issued (see the instructions for the **STOP** submenu on the next page).

```

PROGRAM PARAMETERS of SITE NAME
Model GF868 GF3G
With 1K FIFO and 1113 receiver board.
At 9:54:39 AM on 11 FEB 99

ACTIVE PARAMETERS:

Site status           Burst
Skon/measure mode    Skon Only

SYSTEM PARAMETERS:

no LABEL      No MESSAGE
System Units   ENGLISH
Totalizer Option Automatic
Volumetric Units Thousands ACF
Volumetric Time /min
VOL Decimal Digits 0
Totalizer Units Actual cubic ft
TOT Decimal Digits 0
Mass Flow Units Pounds
MDOT Decimal Digits 0
Mass Units Pounds
Mass Decimal Digits 0

PIPE PARAMETERS:

Transducer number 81
Pipe OD           12.000 inches
Pipe Wall         0.200 inches
Path Length       16.97 inches
Axial Dimension L 12.00 inches
Multi K-factors   OFF

```

Figure 4-5: Typical Site File Printout

4.5 Stop Printing

Use the **STOP** submenu to terminate the printing of live, logged or site data. To stop any active printing activity, see Figure A-6 on page A-6 and complete the following steps:

IMPORTANT: Make sure that a printer has been properly set up before proceeding with this section.

1. To access the *Print Menu*, press the **[PRNT]** key.

Note: *The Print Menu is not protected by the security feature and a password is never required to access this menu.*

2. Press **[F4]** = **STOP**.

3. Press **[F1]** to continue printing or press **[F2]** to *Stop* the currently active printing job.

Note: *After the STOP command has been issued, the printer will complete the printing of any data already in the printer buffer. Either wait for the printer to finish or turn the printer off to empty the buffer immediately.*

The Model GC868 returns to the standard data display screen and normal measurement taking.

4.6 Setting Up a Printer

Use the **PRNTR** submenu to specify the type of printer connected to the Model GC868. To set up a printer, refer to Figure A-6 on page A-6 and complete the following steps:

IMPORTANT: A printer must be properly set up before proceeding to any of the other sections in this chapter

1. To access the *Print Menu*, press the **[PRNT]** key.

Note: *The Print Menu is not protected by the security feature and a password is never required to access this menu.*

2. Press the **[←]** or **[→]** key to display the option bar shown, and then press **[F1]** to select the **PRNTR** submenu.

3. Use the **[←]**, **[→]** and **[F1]**-**[F4]** keys to select the desired *Printer Type*. See Table 4-3 below for a complete list of the available options.

Note: *For compatibility with the Model GC868, the printer must have an RS232 serial interface. To use a printer with a parallel interface, a serial-to-parallel adapter must be used.*

Table 4-3: Available Printer Options

Key(s)	Printer Type	Description
[F1]	DP411	Seiko Model DPU-411 Type II
[F2]	XTECH	Extech Mini Serial Printer 42
[F3]	EPSON	Epson or Epson-compatible
[F4]	KODAK	Kodak Diconix 150 Plus
[→]+[F1]	SP401	Syntest SP-401

After the desired printer type has been selected, the meter returns to the standard data display screen and normal measurement taking.

4.7 Printing Signal Array Data

Use the **SGNLS** submenu to print signal array data, to help diagnose certain problems. To print the signal data, see Figure A-6 on page A-6 and complete the following steps:

IMPORTANT: Make sure that a printer has been properly set up before proceeding with this section.

1. To access the *Print Menu*, press the **[PRNT]** key.

Note: *The Print Menu is not protected by the security feature and a password is never required to access this menu.*

2. Press the **[←]** or **[→]** key to display the option bar shown, and then press **[F2]** to select the **SGNLS** submenu.

3. Press the **[F1]**-**[F3]** keys to select the desired *Signal Array* data to print. To abort the procedure, press the **[EXIT]** key.

Note: *The **SIGNL** option causes the raw signal array data to print, while the **CROSS** option causes the cross-correlation data to print. The **BOTH** option prints both sets of data.*

After the desired print selection has been made, the Model GC868 returns to the standard data display screen and normal measurement taking. The specified signal array data is printed continuously, until it is manually stopped. To terminate signal array printing, use the **STOP** submenu, as described earlier in this chapter. A portion of a typical printout is shown in Figure 4-6 below.

CH1	SKAN	SIGNAL
0	0	0
1	0	0
2	0	0
.		
.		
757	40	44
758	41	45
759	40	42
760	34	34
761	32	34
762	36	38
763	36	36
.		
.		
.		

Figure 4-6: Typical Signal Array Printout

The data printed via the **SIGNL** submenu consists of 1024 lines, each of which lists the following three values:

- **Index** – this is the printout line number, which locates the data point within the complete body of data.
- **Upstream** – this is the amplitude of the signal from the upstream transducer at the listed index number.
- **Downstream** – this is the amplitude of the signal from the downstream transducer at the listed index number.

Note: *The printouts generated from the **CROSS** and **BOTH** submenus will appear after the **SIGNL** printout, as separate listings.*

The data printed in this array permits a comparison of the relative signal strengths of the upstream and downstream transducers, which are used to calculate a single flow measurement.

4.8 Printing RTD Data

Use the RTDs submenu to send the numeric point value of a connected RTD device to the RS232 port for display on a terminal or RS232 printer. By viewing the point value of the meter at a given temperature, you can calculate the points at the Set Temperature, and the slope of the RTD input in points/degree. (See Chapter 1, *Calibration*, of the *Service Manual* for more details.)

1. To access the *Print Menu*, press the **[PRNT]** key.

Note: *The Print Menu is not protected by the security feature and a password is never required to access this menu.*

2. Press the **[←]** or **[→]** key to display the option bar shown, and then press **[F3]** to select the **RTDs** submenu.
3. At the *Dump RTD Data* prompt, press **[F1]** to leave the **PRINT** menu without dumping data, or **[F2]** to send the RTD data to the RS232 port.

After the selection has been made, the Model GC868 returns to the standard data display screen and normal measurement taking. If you have selected **YES** at the **DUMP RTD DATA** prompt, the meter continues to send data until you reenter the **PRINT** menu and select the **STOP** option.

Chapter 5. Clearing Data.

Introduction.....	5-1
Reset Totals	5-1
Deleting Site Files.....	5-2
Deleting Log Files.....	5-2

5.1 Introduction

This chapter explains how to purge the Model GC868's memory of various measurement totals and/or files. The *Clear Menu*, which is accessed by pressing the **[CLR]** key on the keypad, is divided into three submenus:

- **TOTAL** - used to reset totalized measurement values
- **SITE** - used to remove site parameter files from memory
- **LOG** - used to clear log files from memory.

Note: *For detailed information on creating a log file, see Chapter 3, Logging Data. For detailed information on creating a site file and for setting up the stopwatch totalizer, see Chapter 1, Programming Site Data.*

For purposes of this discussion it is assumed that the left pane of the data display screen is active. If the right pane of the data display screen is active, all of the instructions remain the same, except that any references to the **[F1]-[F4]** keys should be replaced by the **[F5]-[F8]** keys.

IMPORTANT: None of the clearing procedures available via the Clear Menu can be undone. Be very sure that the exact consequences of a selected option are thoroughly understood before proceeding.

Refer to Figure A-7 on page A-7 and proceed to the desired section for detailed instructions. Each submenu may be followed in the sequence shown or the **[↑]** and **[↓]** keys may be used to scroll through the prompts.

5.2 Reset Totals

The **TOTAL** submenu permits the user to reset volumetric totals to zero and to reset the stopwatch totalizer. Press the appropriate side of the **[SCREEN]** key to activate the desired pane of the display screen, and complete the following steps:

1. To access the *Clear Menu*, press the **[CLR]** key.
 - a. If you have activated the security feature (see Chapter 1, *Programming Site Data*, page 1-30 for details), enter the assigned password and press **[ENT]**.
2. Press **[F1]** = **TOTAL**.
3. Press **[F1]** to abort the procedure or press **[F2]** to clear all volumetric totals and reset the stopwatch totalizer. In either case, the initial *Clear Menu* prompt returns.

5.2.1 Procedure Options

Do one of the following:

- Press **[F1]-[F3]** to enter one of the **CLR** submenus.
- Press the **[EXIT]** key to return to the data measurement display.

5.3 Deleting Site Files

Use the **SITE** submenu to clear site files from the GC868's memory. Use the **[SCREEN]** key to activate the desired display pane, and complete the following steps:

1. To access the *Clear Menu*, press the **[CLR]** key.
 - a. If you have activated the security feature (see Chapter 1, *Programming Site Data*, page 1-30 for details), enter the assigned password and press **[ENT]**.
2. Press **[F2] = SITE**.
3. At the *Site Name* prompt, use the **[←]**, **[→]** and **[F1]-[F4]** keys to select a site file for deletion. To leave the **SITE** submenu, press the **[EXIT]** key.

Note: *At the Site Name prompt, the option bar shows the names of all site files currently stored in memory.*

4. Press **[F1]** to abort the procedure or press **[F2]** to *Clear* the specified site file. If any site files remain in memory, the **Site Name** prompt repeats.

When all of the stored site files have been cleared or the **[EXIT]** key has been pressed at the **SITE NAME** prompt, the programming sequence resumes at this point.

5.3.1 Procedure Options

Do one of the following:

- Press **[F1]-[F3]** to enter one of the **CLR** submenus.
- Press the **[EXIT]** key to return to the data measurement display.

5.4 Deleting Log Files

Use the **LOG** submenu to clear log files from the Model GC868's memory. Press the appropriate side of the **[SCREEN]** key to activate the desired pane of the data display screen, and complete the following steps:

1. To access the *Clear Menu*, press the **[CLR]** key.
 - a. If you have activated the security feature (see Chapter 1, *Programming Site Data*, page 1-30 for details), enter the assigned password and press **[ENT]**.
2. Press **[F3] = LOG**.
3. At the **Name** prompt, the option bar shows the names of all log files currently stored in memory. Use the **[←]**, **[→]** and **[F1]-[F4]** keys to select a log file for deletion. To leave the **LOG** submenu, press the **[EXIT]** key.
4. Press **[F1]** to abort the procedure or press **[F2]** to *Clear* the specified log file. If any log files remain in memory, the **Name** prompt repeats.

When all of the stored log files have been cleared or the **[EXIT]** key has been pressed at the **Name** prompt, the programming sequence resumes at this point.

5.4.1 Procedure Options

Do one of the following:

- Press **[F1]-[F3]** to enter one of the **CLR** submenus.
- Press the **[EXIT]** key to return to the data measurement display.

[no content intended for this page]

Chapter 6. Serial Communications.

- Introduction..... 6-1
- Wiring the RS232 Interface..... 6-1
- Checking the GC868 Baud Rate 6-2
- Setting Up the Terminal Software and Transferring Data..... 6-2
- The Optional RS485 Serial Interface..... 6-3
- Setting Up an Ethernet Connection 6-7
- Setting Up a MODBUS/TCP Connection..... 6-7

6.1 Introduction

The Model GC868 flowmeter is equipped with a standard RS232 serial interface. By using this interface, any log files stored in the GC868's memory may be easily uploaded to a personal computer. In order to accomplish this, the following steps must be completed:

- Connect the GC868 to the personal computer
- Check the GC868 baud rate setting
- Set up the personal computer's terminal software
- Transfer the log files to the personal computer.

This section also contains instructions for setting up an RS485 serial interface.

6.2 Wiring the RS232 Interface

The first step is to connect the built-in RS232 port in the GC868 to one of the serial ports (COM1 or COM2) on the personal computer. Table 6-1 below lists the standard cables available from the factory for this purpose.

Table 6-1: Panametrics Serial Cables

Part Number	PC Connector	GC868 Connector
704-659	DB-25 Male	Flying Leads (5)
704-660	DB-9 Male	Flying Leads (5)
704-661	DB-25 Female	Flying Leads (5)
704-662	DB-9 Female	Flying Leads (5)

Each of the cables listed in Table 6-2 above is available in several standard lengths. However, a user-supplied cable may be used, if preferred. In either case, wire the GC868 end of the serial cable in accordance with the pin designations listed in Table 6-2 below.

Table 6-2: RS232 Pin Connections

GC868 Pin #	Panametrics Cable Color	DB-25 Cable Pin #	DB-9 Cable Pin #
1 (RTN)	Green	7	5
2 (TX)	Black	3	2
3 (RX)	Red	2	3
4 (DTR)	White	20	4
5 (CTS)	Yellow	5	8

Note: *For basic serial communications between a single GC868 and a personal computer, no connections are required to pins 4 and 5 of the GC868's serial connector. However, these pins should be jumpered together to ensure proper operation.*

6.3 Checking the GC868 Baud Rate

For successful serial communications, the GC868 and the personal computer must be set up to send/receive data at the same speed. To verify or change the *baud rate* setting of the GC868, proceed as follows:

Access the *User Program*, by pressing the [**PROG**] key on the keypad. The standard measurement mode screen will be replaced by the following initial programming mode screen:

PROGRAM		Start	
PROGRAM status			
SETUP	CLOCK	COMM	SAVE

Press the [←] and [→] keys and the [**F3**] key to select the **COMM** submenu.

COMM PROGRAM			
PROGRAM			
Comm port			
BAUD RATE			
current setting appears here			
4800	9600	19200	

To change the baud rate, press the [→] key until the desired baud rate appears on the option bar, and then press the appropriate [**Fx**] function key.

The available rates are 300, 600, 1200, 2400, 4800, 9600 and 19200 baud. After verifying or changing the baud rate setting, press the [**EXIT**] key twice to return to standard measurement mode.

Note: Refer to Chapter 1, Programming Site Data, for a detailed description of using the **COMM** submenu on page 1-26. The description includes information on checking UART bits and network ID.

6.4 Setting Up the Terminal Software and Transferring Data

Specific instructions are given in this manual for communicating with personal computers running under the Windows 9X/NT (page 6-3) operating systems. Proceed to the appropriate section for detailed set up procedures.

Note: For computers operating under other operating systems, contact the factory for assistance or consult the operating system manual supplied with the computer.

6.4.1 Windows 9X/NT Systems

Windows 9X/NT systems use a program called *Hyperterminal* to access the serial ports. To set up serial communications with a personal computer running under Windows 95, Windows 98 or Windows NT, make sure the GC868 is powered on and complete the following steps:

1. From the Windows START menu, select **PROGRAMS > ACCESSORIES > HYPERTERMINAL > HYPERTERMINAL**.
2. The **NEW CONNECTION** window should appear (if it does not, select it from the **FILE** menu). After entering the desired **CONNECTION NAME** and selecting an **ICON**, click on **OK**.
3. When the **CONNECT TO** window appears, select the serial communications port (**COM1** or **COM2**) to which the GC868 is connected and click on **OK**.
4. When the **COMx PROPERTIES** window appears, make sure the settings are as follows:
 - Bits per Second: 9600 (must match the GC868 setting)
 - Data Bits: 8
 - Parity: None
 - Stop Bits: 1
 - Flow Control: None

After making any necessary changes, click on **OK**.

5. Open the **TRANSFER** menu and select **CAPTURE TEXT**. Enter the desired **DRIVE: \ DIRECTORY \ FILENAME** for the file about to be transmitted, and click on **OK**.
6. From the keypad on the GC868, enter the **PRINT** menu and select the log file to be uploaded to the computer in numeric format. See Chapter 4, *Printing Data*, for detailed instructions on this procedure.
7. The logged data will begin appearing on the computer screen. When the transfer has been completed, open the **TRANSFER** menu and select **CAPTURE TEXT > STOP**. The uploaded file may now be used in any software program, just like any other text file.

Note: *If the RS232 link does not function, switching the leads to pins 2 (TX) and 3 (RX) at the RS232 connector on the meter often solves the problem.*

6.5 The Optional RS485 Serial Interface

Although the standard RS232 serial interface included with the Model GC868 is adequate for most applications, Panametrics offers an optional RS485 serial interface upgrade for special situations. The Model GC868 is easily modified to provide RS485 communications, and this section describes the wiring and use of the special RS232 to RS485 converter.

Note: *For compliance with the European Union's Low Voltage Directive (73/23/EEC), this unit requires an external power disconnect device such as a switch or circuit breaker. The disconnect device must be marked as such, clearly visible, directly accessible, and located within 1.8 m (6 ft) of the electronics console.*

6.5.1 Interface Converter Mounting

A special bracket containing the serial interface converter and a three-terminal barrier strip is mounted inside the Model GC868, just below the RS232 terminal block (see Figure 6-1 below). The standard **RS232** terminal block is wired to the input of the serial interface converter, and the RS485 output of the serial interface converter is wired to the barrier strip.

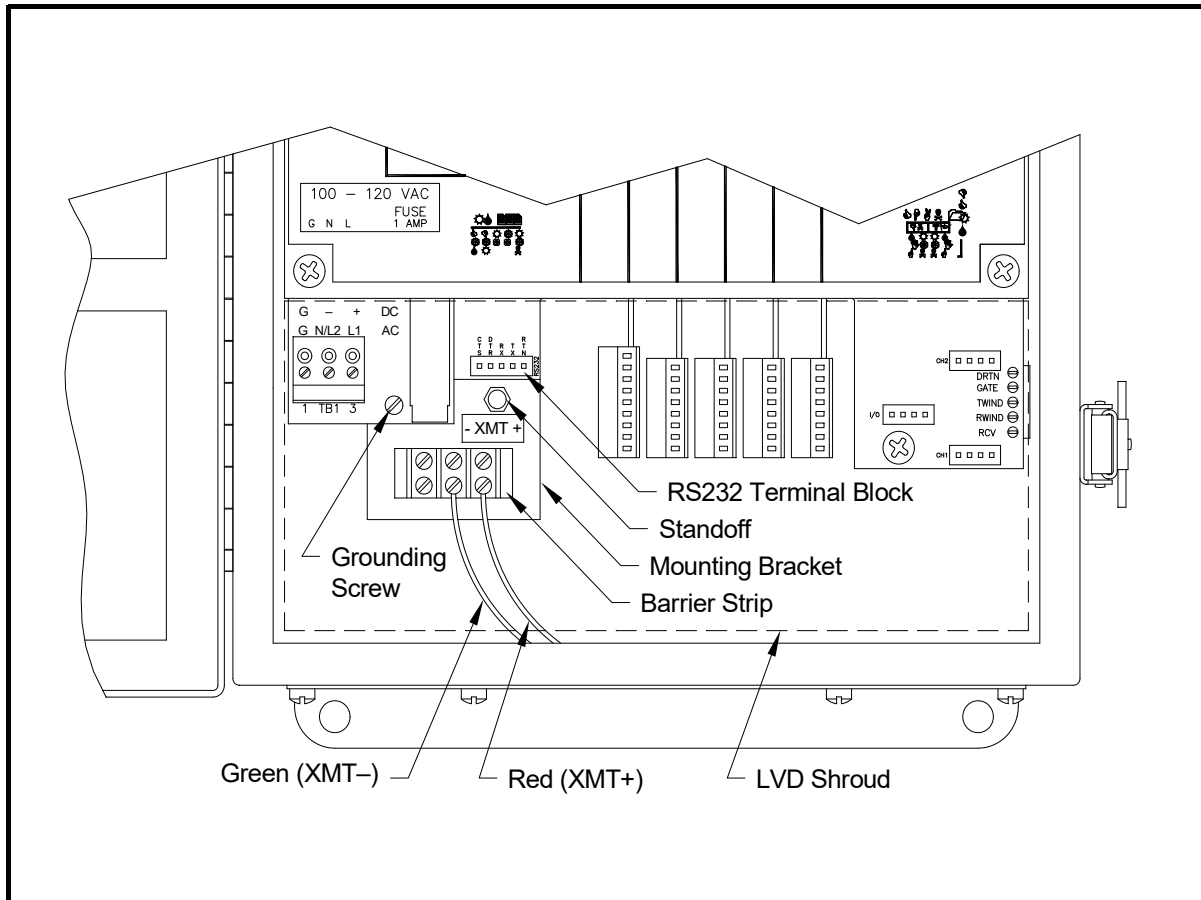

Figure 6-1: Interface Converter Mounting

6.5.2 Point-To-Point Wiring

Standard factory wiring of the RS485 serial interface is configured for point-to-point wiring. That is, a single Model GC868 may be wired directly to a single personal computer. To connect the RS485 serial interface, refer to Figure 6-1 on page 6-4 and complete the following steps:

Note: For compliance with the European Union's Low Voltage Directive (73/23/EEC), a transparent plastic shroud protects the electrical connections. The shroud must remain in place, except while wiring the unit. Reinstall the shroud after the wiring has been completed.

1. Disconnect the *main power* to the electronics console and open the cover.



WARNING! Dangerous voltages exist within the electronics console. Do not perform any wiring operations until the main power to the unit has been disconnected.

2. Remove the clear plastic *shroud* that covers the electrical connectors.

- Using a *twisted-pair wire*, connect the XMT+ terminal of the barrier strip to the T+/R+ terminal of the PC's RS485 adapter and connect the XMT- terminal of the barrier strip to the T-/R- terminal of the PC's RS485 adapter (see the documentation provided with the RS485 adapter for details).

Note: *The XMT+ terminal on the barrier strip is the screw opposite the red wire connection and the XMT- terminal on the barrier strip is the screw opposite the green wire connection.*

- Reinstall the clear plastic shroud, close the cover to the electronics console and reconnect the main power.

The RS485 serial interface is now ready for point-to-point operation.

6.5.3 Multi-Point Wiring

The standard point-to-point wiring configuration for the serial interface converter may be modified to permit the use of a multi-point wiring arrangement. In a multi-point RS485 system, one flowmeter (the master) is connected to the personal computer, while a number of additional flowmeters (the slaves) are chained together and connected to the master flowmeter. In order to implement such a system, the **DIP** switch settings inside each serial interface converter must be changed.

IMPORTANT: The serial interface converter in the last slave unit in the chain should not be reconfigured.

6.5.3.1 Reconfiguring a Serial Interface Converter

To reconfigure a serial interface converter for multi-point wiring, complete the following steps:

- Disconnect the *main power* to the electronics console and open the cover.



WARNING! Dangerous voltages exist within the electronics console. Do not perform any wiring operations until the main power to the unit has been disconnected.

- Remove the clear plastic *shroud* that covers the electrical connectors.
- Remove the serial interface converter *mounting bracket* by removing the standoff located just below the **RS232** terminal block and the grounding screw to its left (see Figure 6-1 on page 6-4).
- Loosen the two screws that fasten the DB9 connector to the mounting bracket, and remove the *serial interface converter* from the bracket.
- Use a small screwdriver to pry open the *plastic case* of the serial interface converter, as shown in Figure 6-2 on page 6-6.

The serial interface converter contains a main printed circuit board and a daughter printed circuit board. The daughter board has a small terminal block attached to it and the main board has a **DIP** switch (**SW1**) mounted near the center of the board.

- Locate the switch assembly on the main board, and move the switch in position 1 from ON to OFF. The standard ON state for this switch is for point-to-point operation, while the OFF state is needed for multi-point operation. See Table 6-3 on page 6-6 for the proper settings of all four switches on the switch assembly.

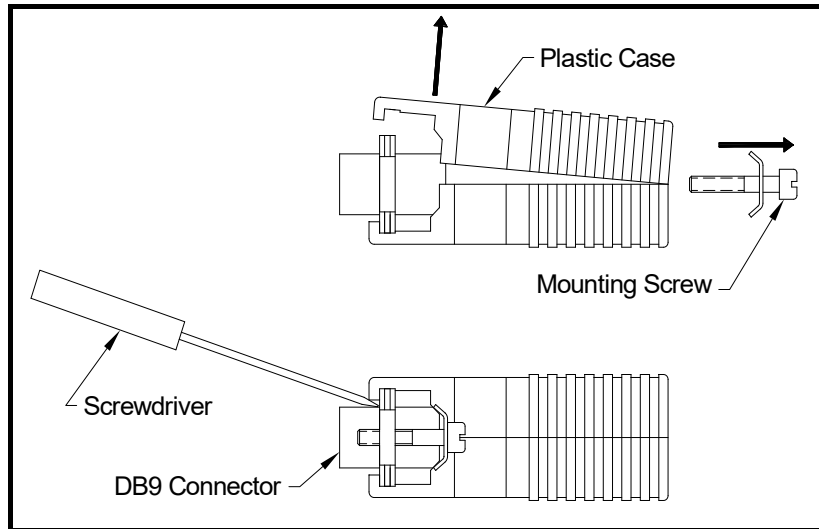

Figure 6-2: Opening the Converter Case

Table 6-3: Switch Assembly Settings

Position #	Point-To-Point	Multi-Point
1	ON	OFF
2	ON	ON
3	ON	ON
4	OFF	OFF

7. Reassemble the serial interface converter and secure it to the mounting bracket with the two mounting screws.
8. Reinstall the mounting bracket into the electronics enclosure and secure it with the standoff and the grounding screw.

6.5.3.2 Wiring the System

After the serial interface converters have been configured for multi-point operation, the system can be wired.

1. Using *twisted-pair wires*, connect the XMT+ terminals of all the flowmeters together and connect the XMT- terminals of all the flowmeters together.

IMPORTANT: Make sure that the flowmeter with the non-modified converter is wired as the last unit in the chain.

2. Using a *twisted-pair wire*, connect the XMT+ terminal of the barrier strip to the T+/R+ terminal of the PC's RS485 adapter and connect the XMT- terminal of the barrier strip to the T-/R- terminal of the PC's 485 adapter (see the documentation provided with the RS485 adapter for details).

Note: *The XMT+ terminal on the barrier strip is the screw opposite the red wire connection and the XMT- terminal on the barrier strip is the screw opposite the green wire connection.*

3. Reinstall the clear plastic shroud, close the cover to the electronics console and reconnect the main power.

The RS485 serial interface is now ready for multi-point operation.

6.6 Setting Up an Ethernet Connection

A modified GC868 can use the Ethernet interface to communicate with an internal network. An optional Ethernet card with a unique MAC (IP) address (installed only in slots 5 or 6) includes an RJ45 connector. To connect the Ethernet-enabled GC868 to the network, insert the jack of an RJ45 cable into the RJ45 connector, route the cable through the bottom of the GC868, and wire the other end of the cable to the LAN according to the manufacturer's instructions.

To establish Ethernet communications with the GC868, you must install the **Ethernet Device Discovery** software utility (available with your modified GC868) on a PC connected to the LAN. Once installed and running, the software displays all Ethernet devices currently connected to the subnet. You can identify the GC868 by its MAC address, supplied as part of customer documentation. The default IP Port is 2101.

The default IP addressing for the GC868 is DHCP (dynamic). If you need to assign a static IP address to the GC868, complete the following steps:

IMPORTANT: To assign a static IP address, the GC868 must be connected to an Ethernet network with a dynamic address assignment mechanism (DHCP) first.

1. Run **Ethernet Device Discovery** software, and identify the GC868's current IP address.
2. Open your Internet browser (Internet Explorer, Netscape, or other) and type the GC868 IP address in the **Address** box.
3. The **Connect ME Configuration and Management** window opens. Two text boxes ask for the user name and password.
 - a. In the **Username** text box, type **root**.
 - b. In the **Password** text box, type **dbps**.
4. At the left of the window, click on **Network**.
5. The **IP Settings** window opens. In the text boxes for **IP Address**, **Subnet Mask**, and **Default Gateway**, type in the new information.
6. Click **Apply**. The software applies the new address.

6.7 Setting Up a MODBUS/TCP Connection

A modified GC868 can use the MODBUS/TCP interface to communicate with an internal network. An optional MODBUS/TCP card with a unique MAC (IP) address (installed only in slots 5 or 6) includes an RJ45 connector. To connect the MODBUS/TCP-enabled GC868 to the network, insert the jack of an RJ45 cable into the RJ45 connector, route the cable through the bottom of the GC868, and wire the other end of the cable to the LAN according to the manufacturer's instructions.

To establish MODBUS/TCP communications with the GC868, you must install the **Ruiping** software utility (available with your modified GC868) on a PC connected to the LAN. Once installed and running, the software displays all Ethernet devices currently connected to the subnet. You can identify the GC868 by its MAC address, supplied as part of customer documentation. The default TCP Port is 502.

The default IP addressing for the GC868 is DHCP (dynamic). If you need to assign a static IP address to the GC868, complete the following steps:

IMPORTANT: To assign a static IP address, the GC868 must be connected to an Ethernet network with a dynamic address assignment mechanism (DHCP) first.

1. Run **Ruiping** software, and identify the GC868's current IP address.
Note: *"Ruiping-e" will return the found IP addresses as well as the MAC address.*
2. From a DOS command prompt, type: **telnet "ip address" 10000**
3. The **"Welcome to Net+Works Configuration Utility"** opens. Type in the login name and password.
 - a. **Login:** type **root**.
 - b. **Password:** type **Netsilicon**.
4. In the Main Menu:
 - a. Select **IP Parameters (1)**. Enter the desired IP changes and return to the Main Menu.
 - b. Select **Enable DHCP Client (3)**. Select N (2) to disable, then select 4 for Main Menu.

At the Main Menu, select 4 for **Quit**. Power cycle the GC868 (i.e., turn the meter off and on) to apply the changes.

[no content intended for this page]

Appendix A. Menu Maps.

- ACTIV, SYSTM, and PIPE Menu Map A-1
- I/O Menu MapA-2
- PROG Menu Map.....A-3
- ADVAN Menu Map (PROG Menu).....A-4
- DISP Menu Map.....A-5
- PRNT Menu MapA-6

[no content intended for this page]

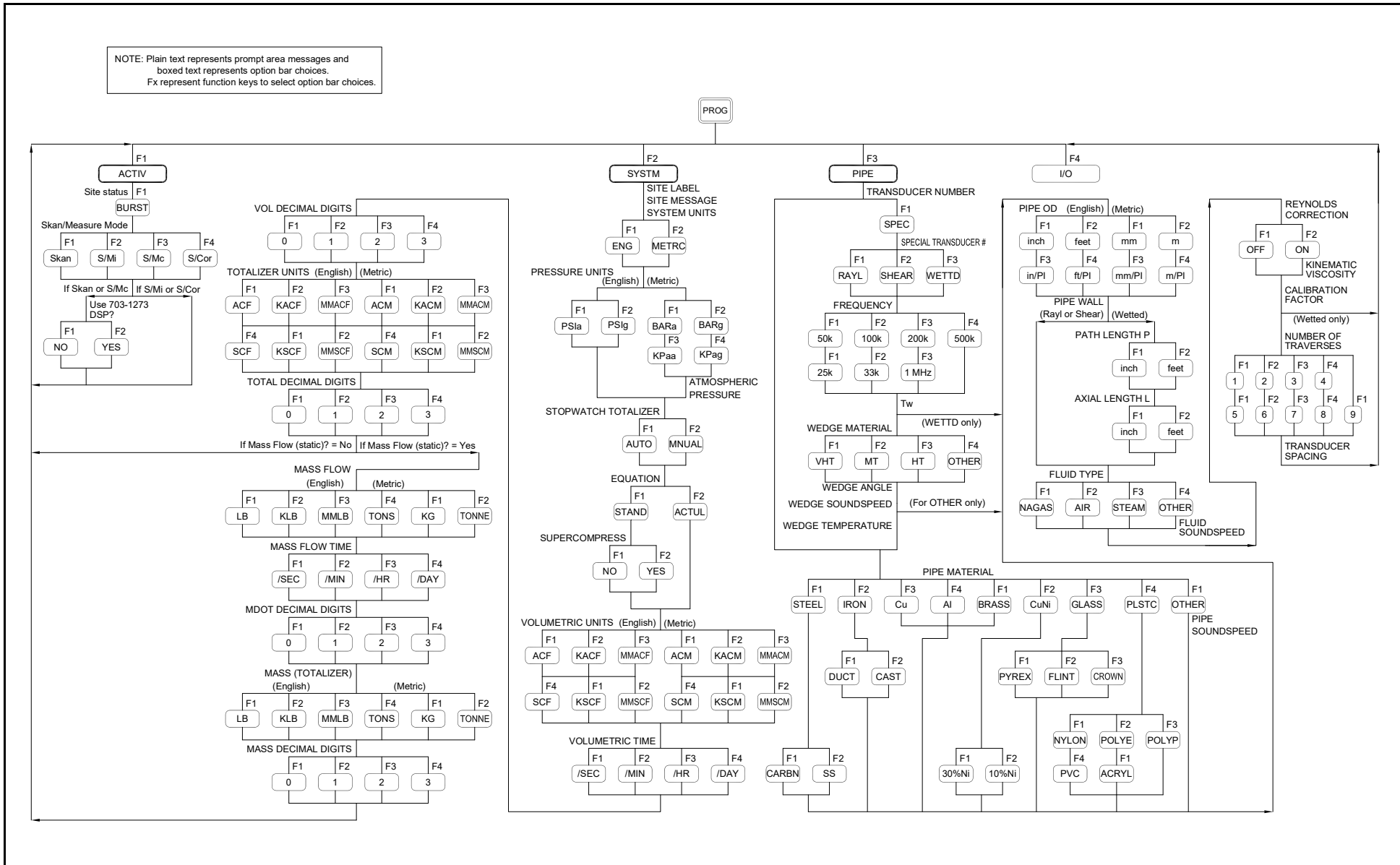

Figure A-1: ACTIV, SYSTM, and PIPE Menu Map

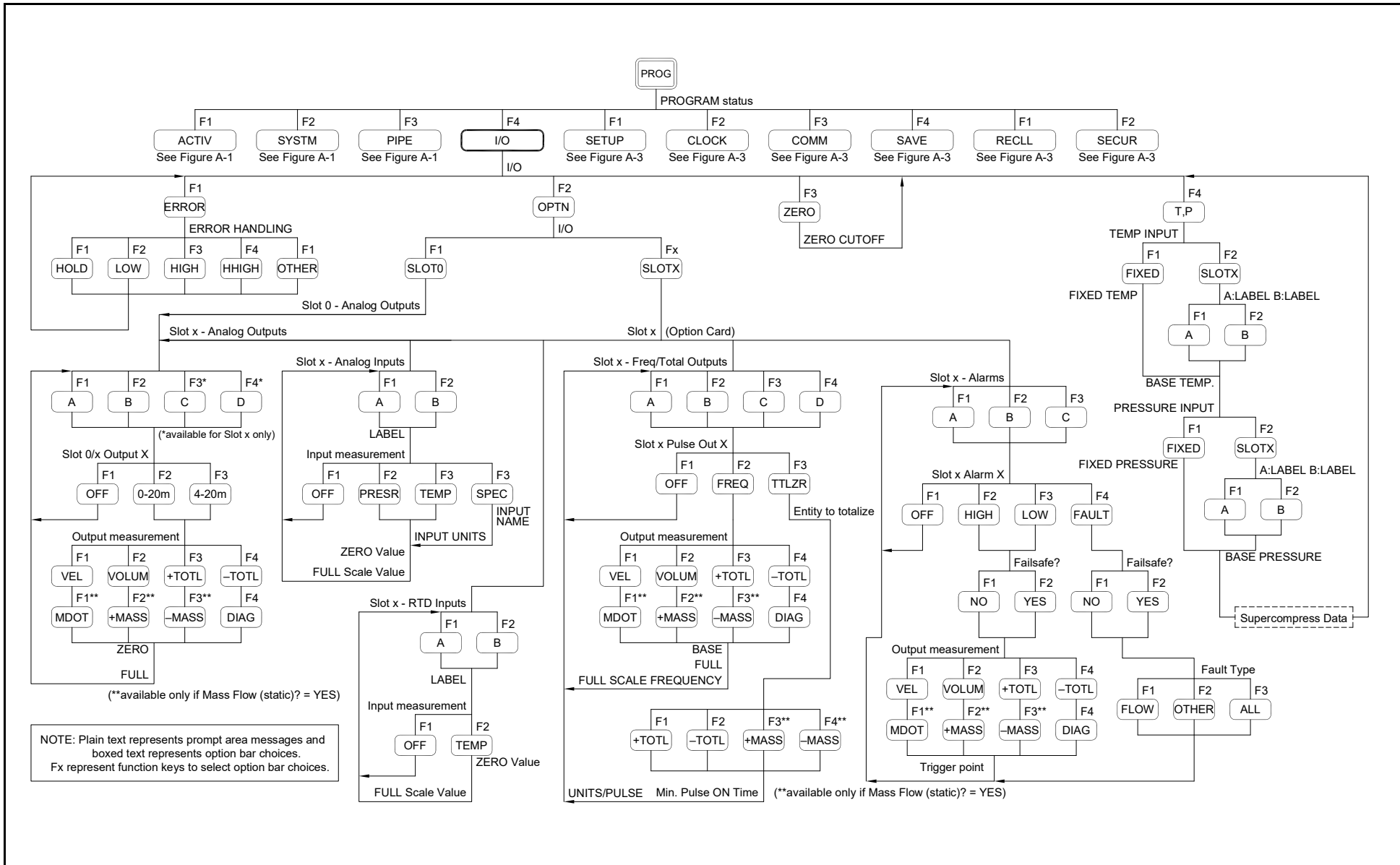

Figure A-2: I/O Menu Map

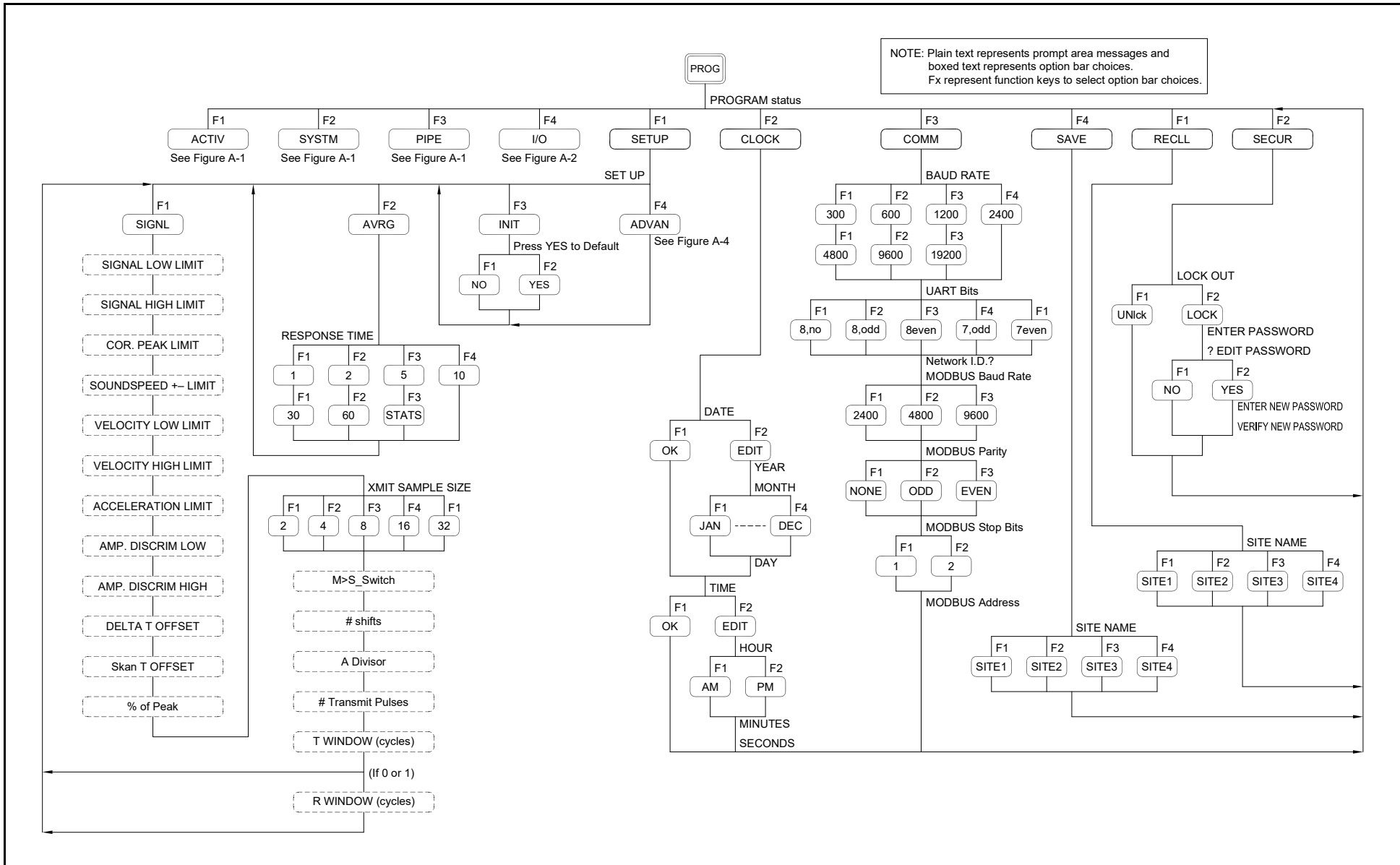

Figure A-3: PROG Menu Map

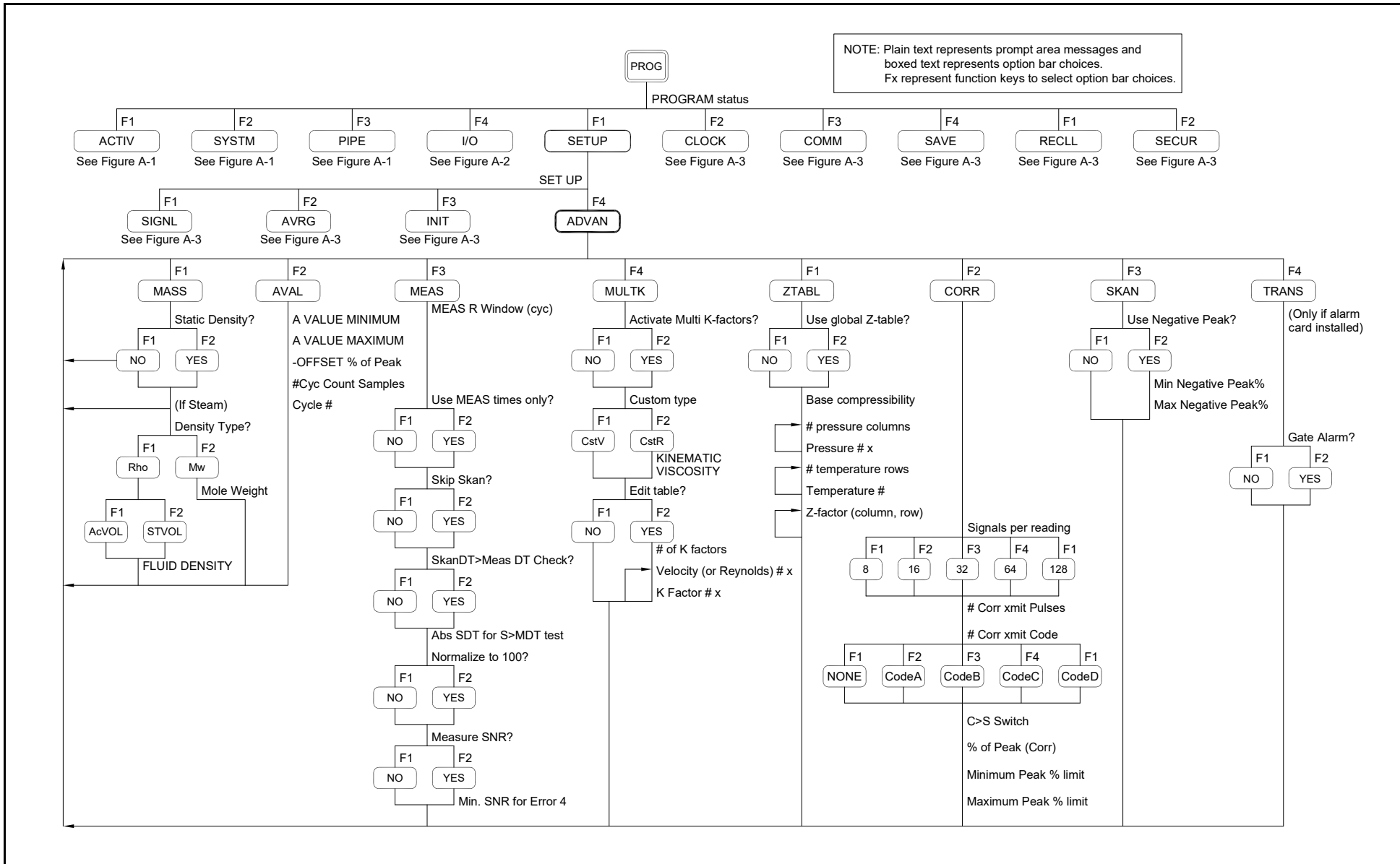

Figure A-4: ADVAN Menu Map (PROG Menu)

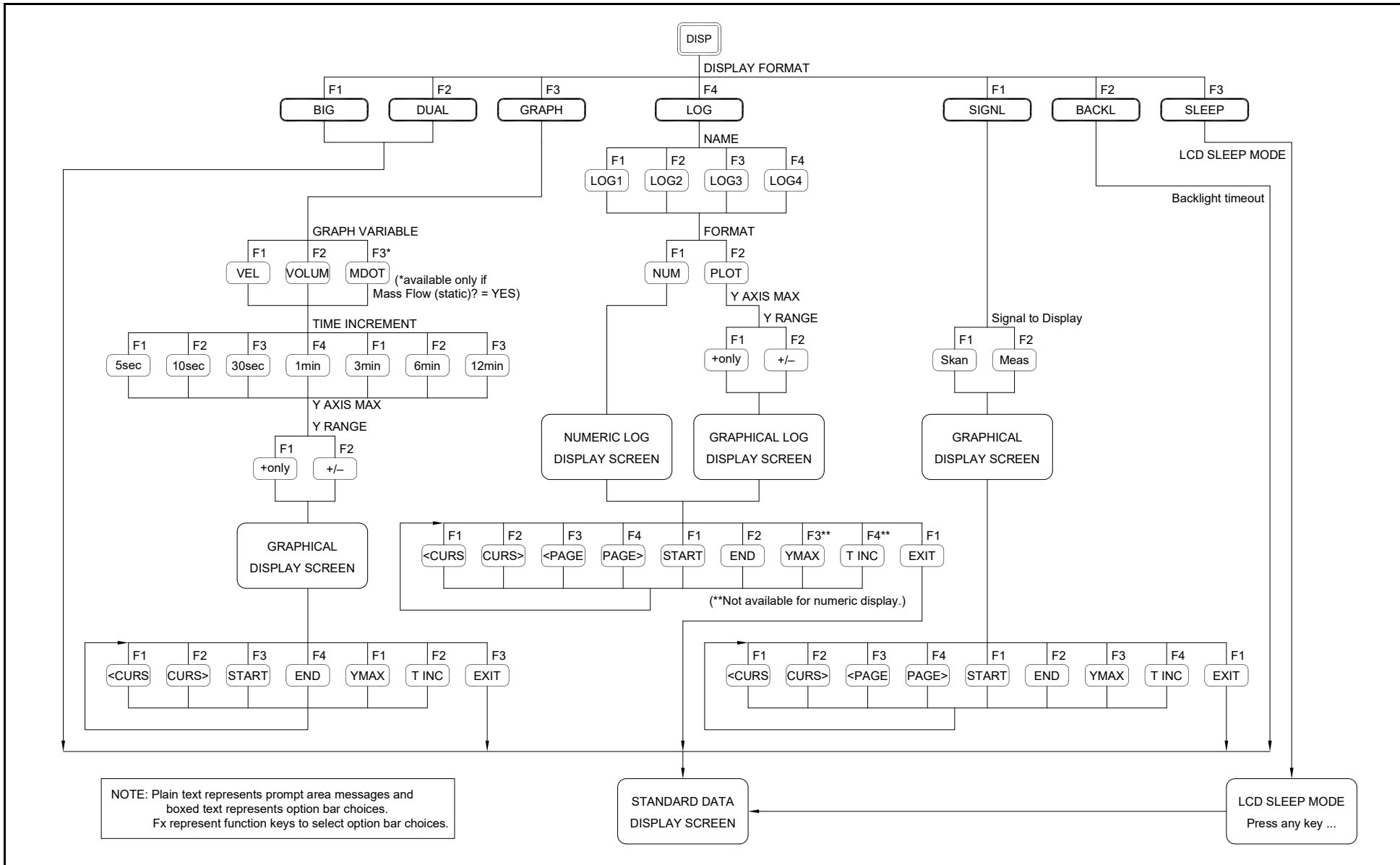

Figure A-5: DISP Menu Map

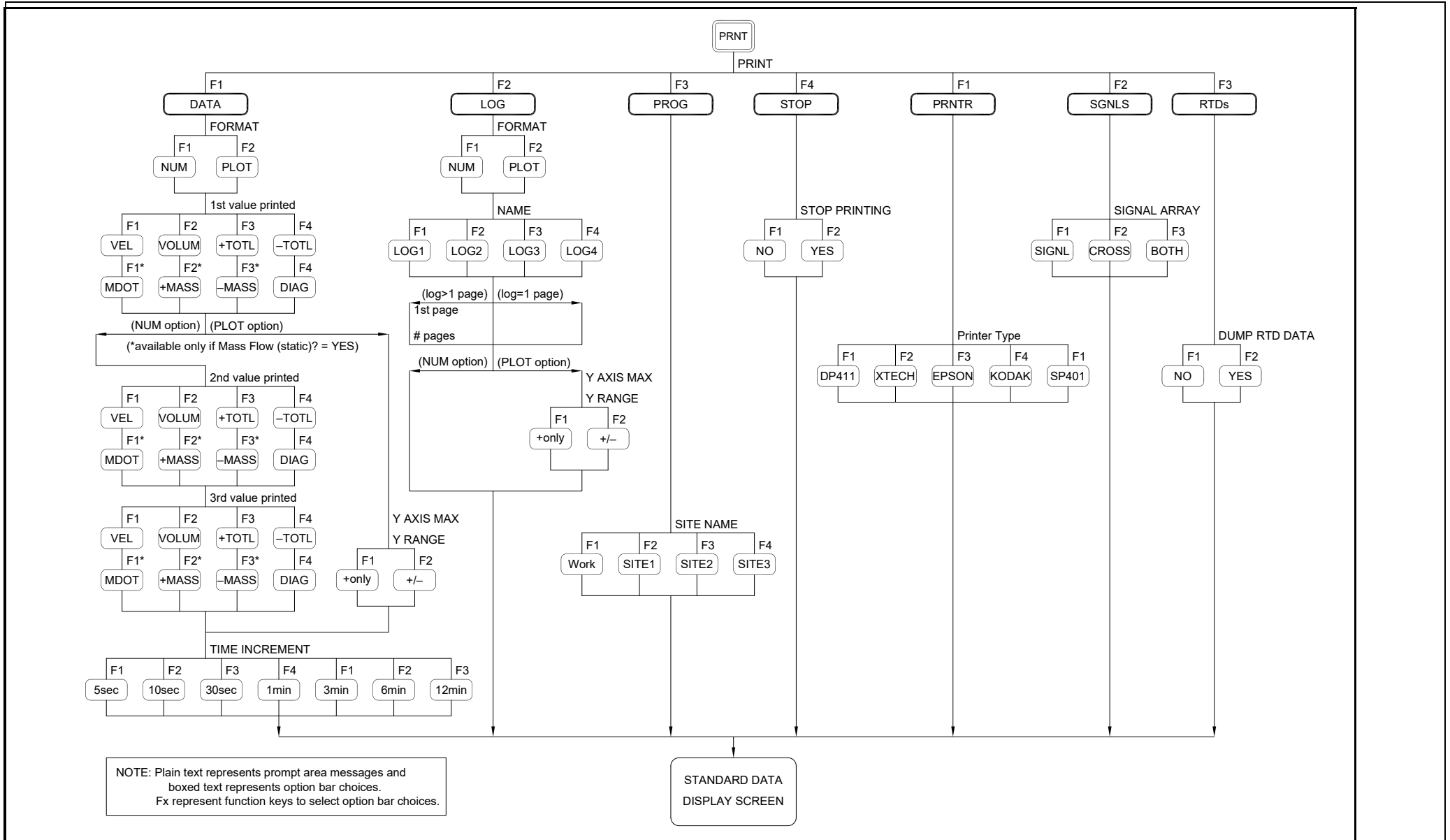

Figure A-6: PRNT Menu Map

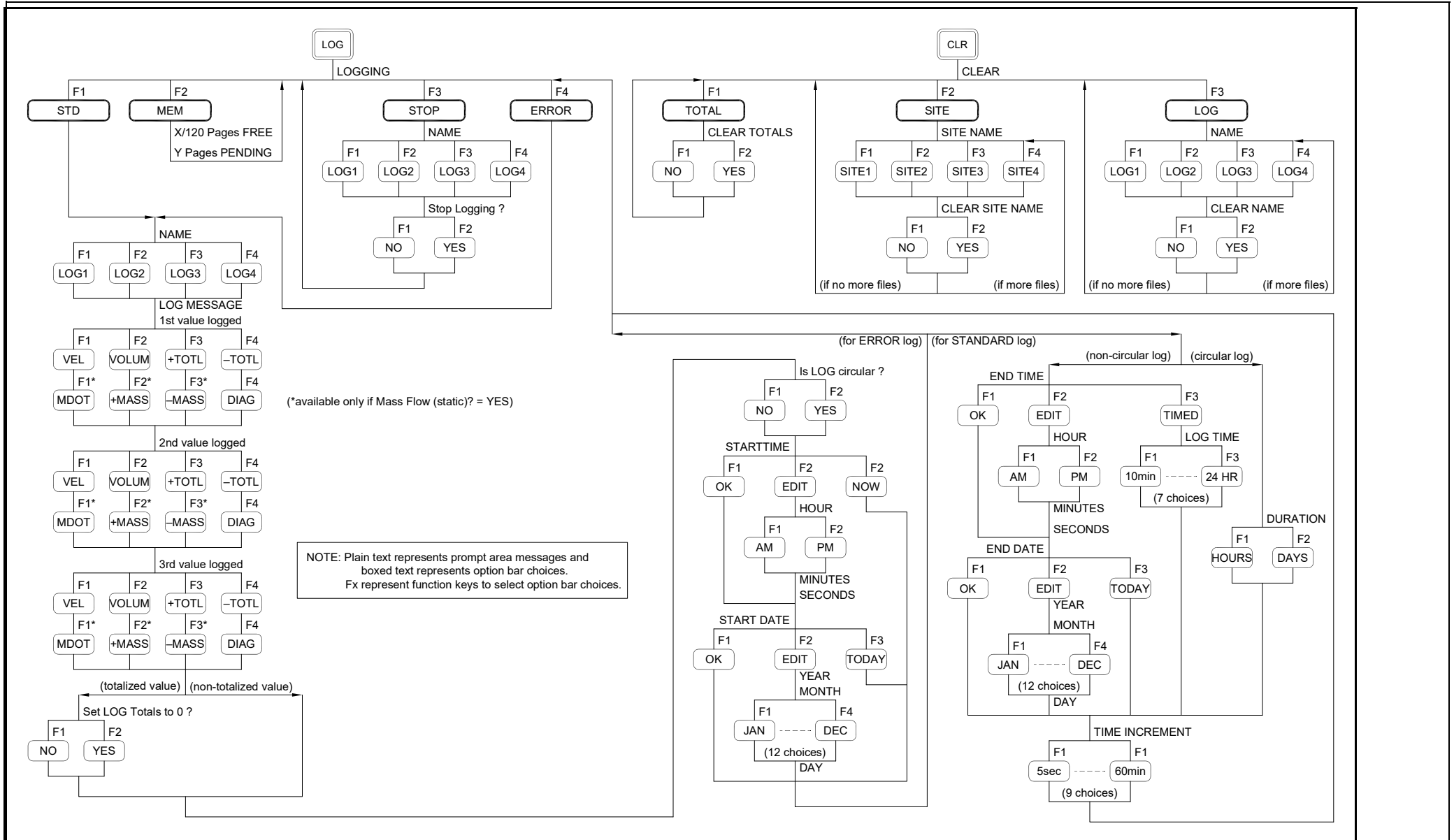

Figure A-7: LOG and CLR Menu Maps

[no content intended for this page]

Appendix B. Data Records.

Option Cards Installed.....	B-1
Initial Setup Data.....	B-2

B.1 Option Cards Installed

Whenever an option card is installed in one of the Model GC868's expansion slots, record the type of card and any additional setup information in the appropriate row of Table B-1 below.

Table B-1: Option Cards Installed

Slot #	Type of Option Card	Additional Setup Information
0	Analog Outputs (A, B)	
1		
2		
3		
4		
5		
6		

B.2 Initial Setup Data

After the Model GC868 flowmeter has been installed, some initial setup data must be entered via the *User Program*, prior to operation. Record that information in Table B-2 below.

Table B-2: Initial Setup Data

General Information					
Model #				Reference	
Software Vers.				Date	
Serial #					
Measurement Method - ACTIV					
Site Status	Burst			Measure Mode	Skat S/Mi S/Mc S/Corr
System Parameters - SYSTEM					
Site Label				Vol. Dec. Digits	
Site Message				Totalizer Units	
System Units	English	Metric		Tot. Dec. Digits	
Pressure Units				If Static Density? = YES	
Stopwatch Total.	Auto	Manual		Mass Flow	
Gas Equation	Standard	Actual		Mass Flow Time	
Supercompress?				MDOT Dec. Dig.	
Vol. Units				Mass (TOT.)	
Vol. Time Units				Mass Dec. Dig.	
Pipe/Transducer Parameters - PIPE					
Std. Trans. #				Path Length (P)	
Spec. Trans. #				Axial Length (L)	
Spec. Trans. Hz				Fluid Type	Nat. Gas Air Steam Other
Spec. Trans. Tw				Other/Sndspd	
Wedge Material				Reynolds Corr.	Yes No
Wedge Angle				Kin. Viscosity	
Temperature or Soundspeed				Cal. Factor	
Pipe Material				# Traverses	
Pipe O.D.				XCDR Spacing	
Pipe Wall					

[no content intended for this page]

Appendix C. Programming with PanaView.

Introduction	C-1
Wiring the RS232 Interface	C-1
Setting Up the Communications Port	C-1
Adding the GC868	C-4
Editing Meter Properties	C-5
Changing Meter Settings	C-12

C.1 Introduction

The PanaView™ graphical user interface offers interactive communications between Windows-based PCs and Panametrics instruments compatible with the company's IDM protocol, such as the GC868 ultrasonic gas flowmeter. PanaView is compatible with 32-bit Windows operating systems such as Windows 98SE, NT 4.0 (with Service Pack 6), 2000, XP and ME. With PanaView, you can:

- load and save site file data
- create and save graph and log files
- display text output and graphs of live measurement data
- create custom templates for displaying text, graph and log data
- interface with multiple Panametrics instruments.

This document focuses on particular applications suitable for the GC868. For general PanaView applications such as creating graph and log files, displaying live measurement data, and creating custom templates, please refer to the general PanaView *User's Manual* (910-211).

C.2 Wiring the RS232 Interface

All IDM-protocol instruments utilize an RS232 interface to communicate with a PC. For details on wiring your RS232 interface, please refer to the *Installation* chapter of your instrument's User's Manual, and to the document *EIA-RS Serial Communications* (916-054).

C.3 Setting Up the Communications Port

Use the steps below to establish communications with the GC868.

1. Open the "New Meter Browser" window and expand the network tree. Then, highlight the *My Computer (Name)* branch by clicking on it.
2. Pull down the "Edit" menu by clicking on it in the menu bar.
3. Click on the "New" menu option to select it, and a submenu opens with two choices on it (see Figure C-1 below).

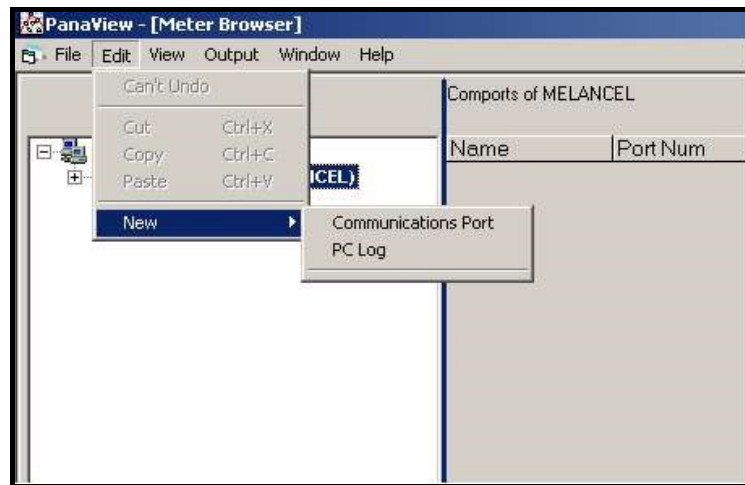

Figure C-1: The Edit Menu

- Click on the "Communications Port" option to select it. The *Setup Communications* screen appears similar to Figure C-2 below.

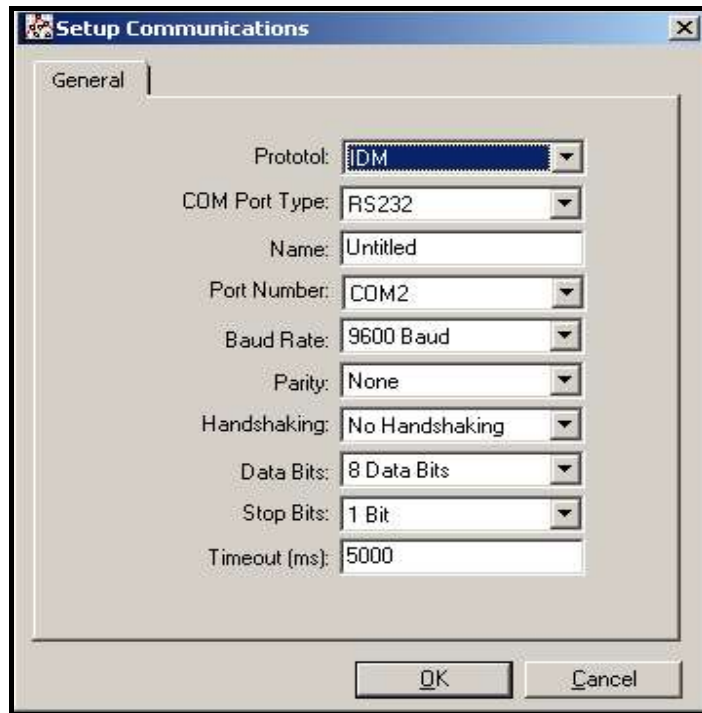

Figure C-2: Setup Communications Screen

- Open the Protocol menu (the first of the drop-down menus) and click on *IDM*.
- Open the COM Port Type menu and click on the desired type (or on *TCP/IP*, if the GC868 is using an Ethernet connection).

Note: *If you select TCP/IP, the menu changes. Proceed to the next page.*

- Select any suitable available baud rate. A baud rate of 19,200 is appropriate for almost all applications. However, if you experience periodic communication reliability problems, you may wish to consider lowering the baud rate on your instrument and in PanaView.

IMPORTANT: *Be sure all the communications port settings match those made in setting up the meter's serial port.*

- Click [OK] to complete data entry.

C.3.1 Setting up Ethernet Communications

If you have selected TCP/IP in step 6 on the previous page, the Setup Communications window appears similar to Figure C-3 below.

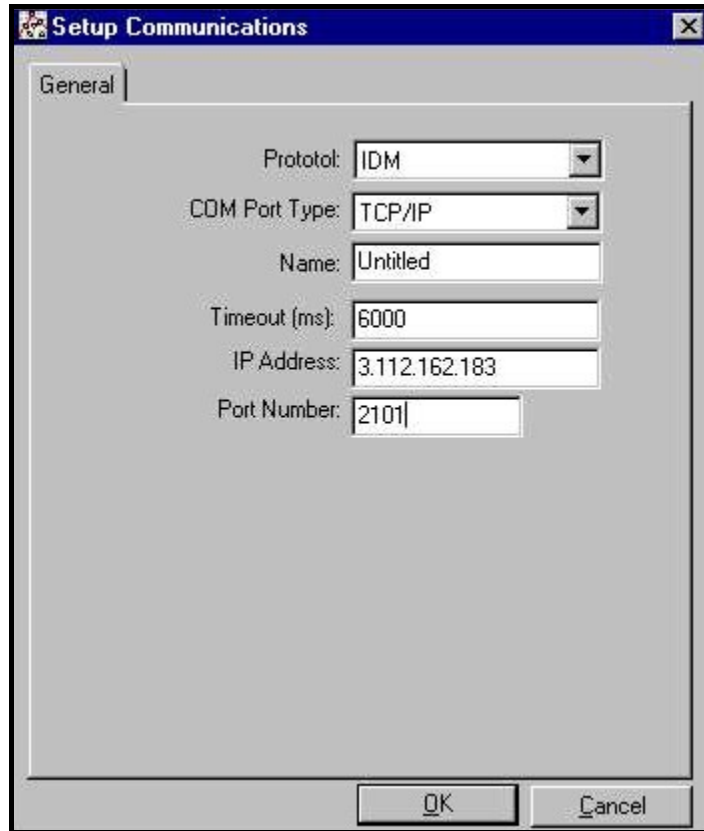

Figure C-3: Setup Communications for TCP/IP

1. Type in the desired *Name* and *Timeout* (in milliseconds).
2. In the *IP Address* text box, enter the IP address. If the IP address is unknown, run the Device Discovery software utility. All units found will be identified by their MAC address and the assigned IP address. In the *Port Number* box, enter 2101 (the default value).
3. Click [OK] to complete data entry.

IMPORTANT: *If you are using Ethernet communications, be sure the GC868 is set up with the default communications parameters: 9600 baud, no parity, no handshaking, 8 data bits and 1 stop bit. The port number must match the "Enable Raw TCP access using TCP Port" assignment shown under the Device Discovery "TCP Server Settings" menu (Configuration>Serial Ports>Port).*

C.4 Adding the GC868

To add the GC868 on the IDM-configured communications port, complete the following steps:

1. Highlight the communication port to which the meter will be added by clicking on it, and then open the "Edit" menu on the menu bar (if the communication port is not highlighted first, the "New Meter" option is not active in the "Edit" menu).
2. Click on the "New" option in the "Edit" menu (see Figure C-4 below).

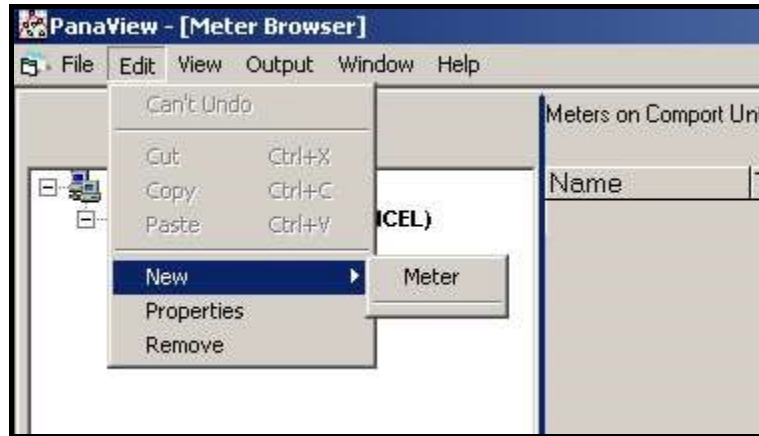

Figure C-4: "New" Option in the "Edit" Menu

3. After clicking on the "New" option, the "Meter" menu option appears. Click on this option to select it.
4. The "New IDM Meter" screen (shown in Figure C-5 below) opens. Enter the Network ID number for the meter, and click [OK].



Figure C-5: New IDM Meter Screen

IMPORTANT: *The Network ID number must match the Network ID programmed in the meter's Communications menu.*

If the initialization is successful, the Meter Browser shows a listing similar to Figure C-6 below.

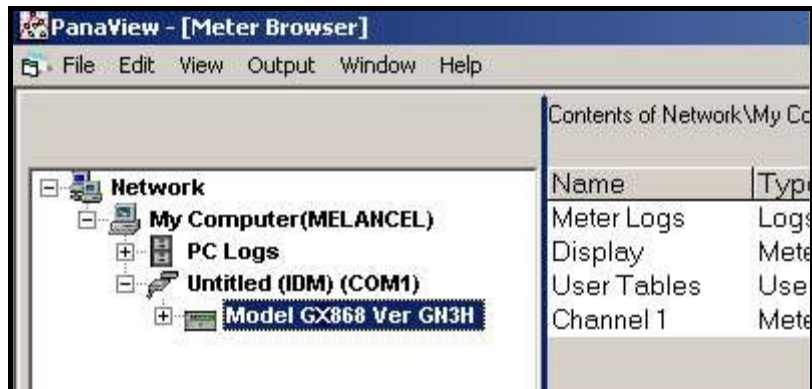

Figure C-6: The Updated Network Tree

Note: *The model number and version that appear will vary with your particular meter and software version.*

However, if the settings do not match, or there is some other difficulty, a screen appears similar to Figure C-7 below.

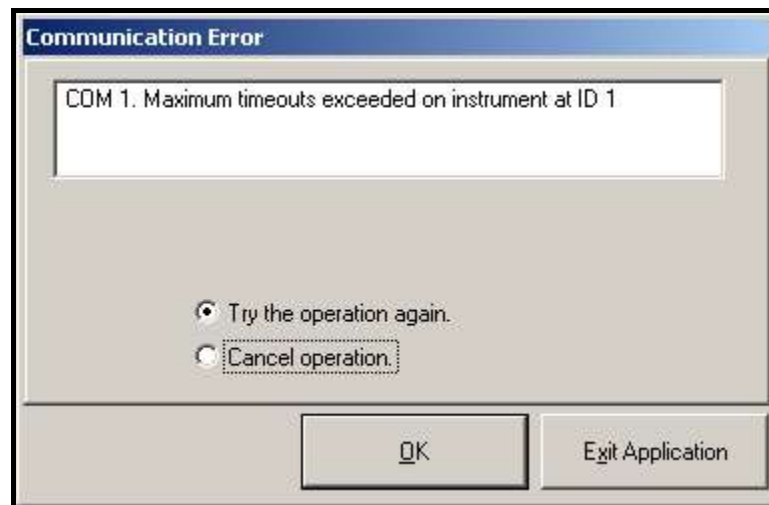

Figure C-7: Communication Error Screen

The screen offers the options of trying again or of canceling the operation. Click on the desired choice, and then on [OK] to confirm the choice or on [Exit Application] to close PanaView.

Note: *If you cannot resolve the problem, contact the factory for help.*

C.5 Editing Meter Properties

Through PanaView, you can edit the properties of your GC868. You can:

- Set the meter clock, or synchronize it with the PC clock
- Read, plot and save transducer signals
- Clear totalizers
- Save site files to the meter or PC
- Clear sites from the meter
- Print site files to the PC

To edit the properties of your GC868:

1. Highlight the meter (as shown in Figure C-6 on page C-5).
2. Open the "Edit" menu and select the "Properties" option, as shown in Figure C-8 below.



Figure C-8: The Properties Option in the Edit Menu

The window appears similar to Figure C-9 below. To perform a specific task, refer to the appropriate section on the following pages.

- Setting the Meter Clock (page C-9)
- Reading Transducer Signals (page C-10)
- Plotting Transducer Signals (page C-10)
- Saving Transducer Signals (page C-11)
- Clearing Totalizers (page C-11)
- Handling Site Files (page C-12)

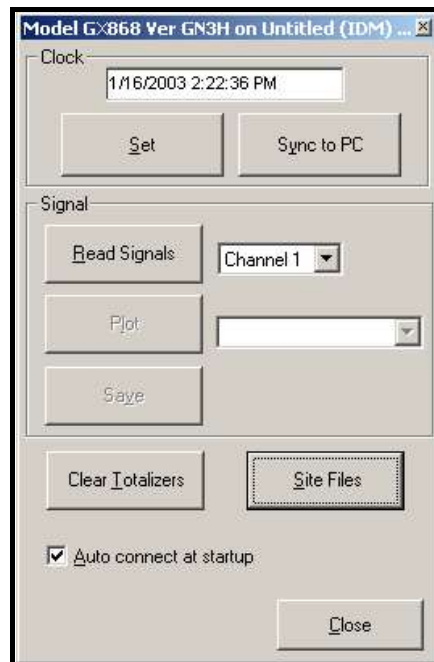

Figure C-9: Properties Window for IDM-Based Meter

Note: For illustration purposes, the meter shown here is a one-channel GX868 flowmeter. Specific parameters will vary with your particular meter.

C.5.1 Setting the Meter Clock

The meter's *Time* may be reset in three different ways:

- manually enter the time and date in the text box, or
- click on the [Sync to PC] option button to have PanaView set the time and date to the current PC setting, or
- click on the [Set] option button to open the dialog box shown in Figure C-10 below. Set the desired date and time as indicated, and click on the [OK] option button.



Figure C-10: Time and Date Selection Window

C.5.2 Reading Transducer Signals

To read a *Signal* from the meter:

1. Click on the *Read Signals* button. (If the meter is a multi-channel instrument, open the Channel drop-down menu and click on the desired channel.) After a moment, the *Properties* window appears similar to Figure C-11 below.

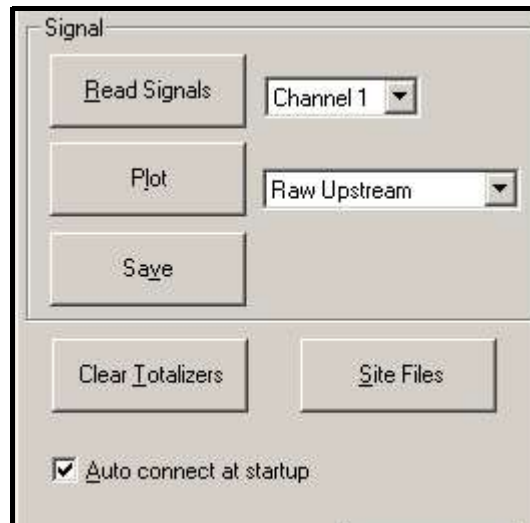

Figure C-11: Active Signal Options

2. To select a different signal type, open the signal menu at the right (shown here with *Raw Upstream* highlighted) and click on the desired signal.

C.5.3 Plotting Transducer Signals

To *plot* the selected signal, click on *Plot*. A graphical window opens, as shown in Figure C-12 below.

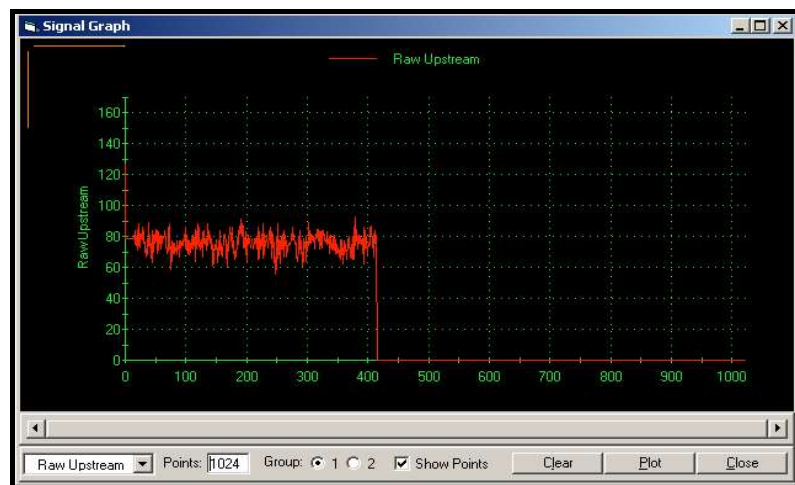

Figure C-12: Signal Graph Window

C.5.4 Saving Transducer Signals

To *save* the raw signal, click *Save*. A window opens similar to Figure C-13 below. Enter the desired name, and click *Save* to save the signal as a text file.

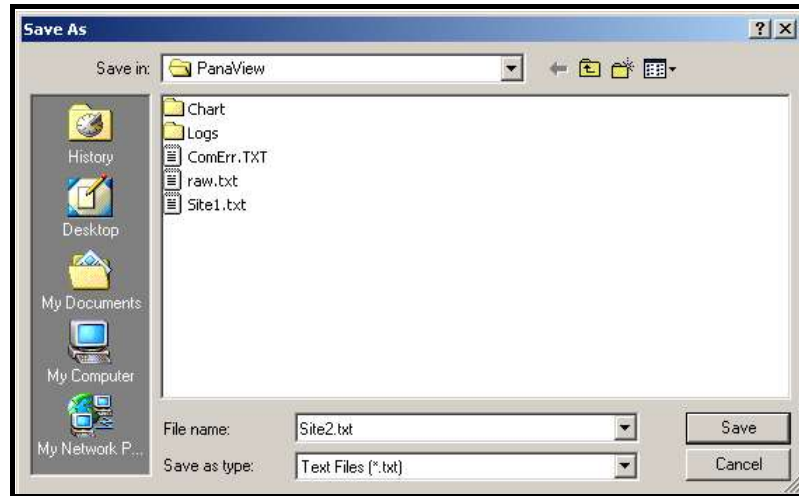

Figure C-13: Save As Window

C.5.5 Clearing Totalizers

To clear the meter totalizers, click on the *Clear Totalizers* button in the *Properties* window. The meter totalizers are reset to 0.

C.5.6 Handling Site Files

To access site files, click on the *Site Files* button in the *Properties* window. The *Site File Operations* window (shown in Figure C-14 below) opens.

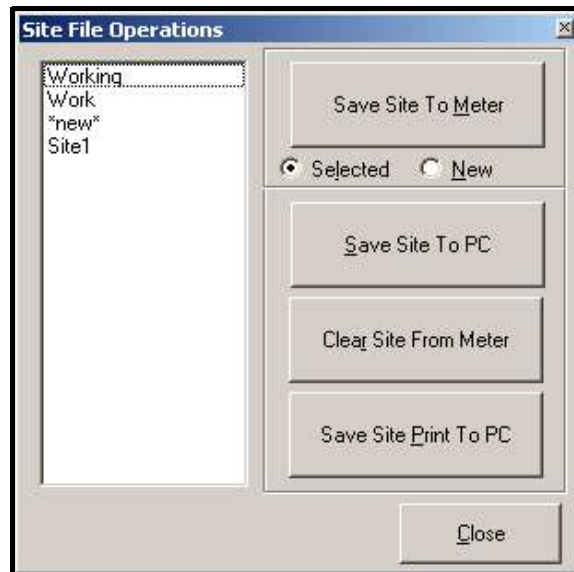

Figure C-14: The Site File Operations Window

C.5.6.1 Saving an Existing Site to the Meter

To save an existing site to the meter:

1. Select the radio button for *Selected* and highlight an existing site in the left pane.
2. Then click on the *Save Site to Meter* button. A screen opens similar to Figure C-15 below.

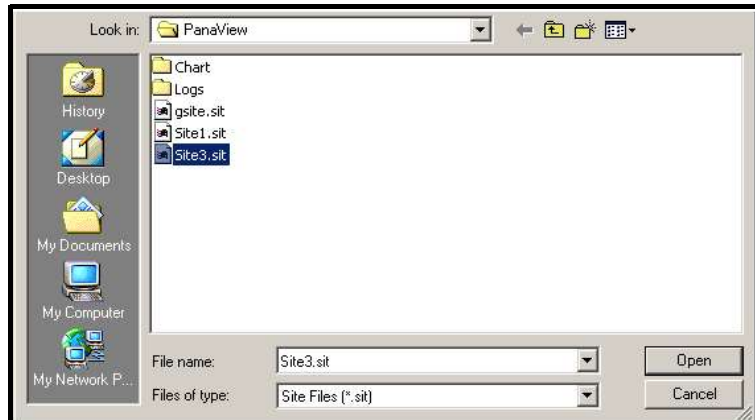

Figure C-15: Site File Selection

3. Highlight the desired site and click *Open*. PanaView sends the site to the meter.

C.5.6.2 Saving a New Site to the Meter

To save a new site to the meter:

1. Select the radio button for *New* and click on the *Save Site to Meter* button.
2. A window opens similar to Figure C-16 below. Enter the desired name, and click [OK].



Figure C-16: Site Name Entry Window

3. The *Site File Selection* window (Figure C-15 on page C-10) opens. Highlight a site with the desired settings, and click [Open]. PanaView saves the site in the meter with the new name and the desired settings.

C.5.6.3 Saving a Site to the PC

To save a site to the PC:

1. Highlight the desired site in the left pane. (See Figure C-14 on page C-9.)
2. Click *Save Site to PC*. A window opens similar to Figure C-13 on page C-9.
3. Enter the desired site name and click [Save]. PanaView saves the site in the PanaView folder unless otherwise specified.

Note: *If you have created a site on the meter after opening the Site File Operations window, you must close and reopen the window to click on the new site.*

C.5.6.4 Clearing a Site from the Meter

To clear a site from the meter:

1. Highlight the site in the left pane. (See Figure C-14 on page C-9.)
2. Click *Clear Site From Meter*.
3. The program asks for confirmation. Click [OK]. The meter deletes the designated file.

C.5.6.5 Saving a Site in Text Form

To store the data from a site file as a text file for display or printout:

1. Highlight the site in the left pane. (See Figure C-14 on page C-9.)
2. Click *Save Site Print to PC*.
3. The *Site File Selection* window (shown in Figure C-15 on page C-10) opens. Enter the desired site name (now with a .prt suffix) and click [Save]. PanaView displays a text version of the site, as shown in Figure C-17 below.

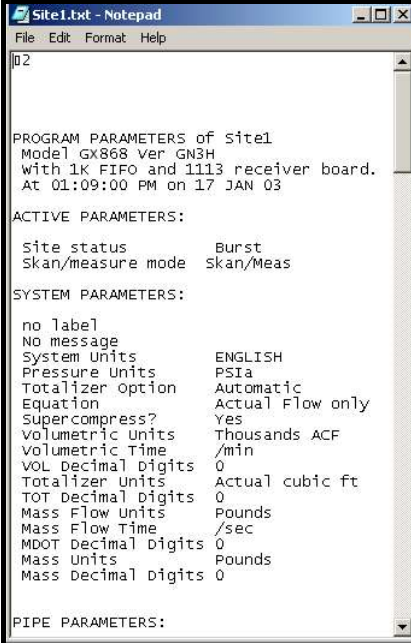

```

Site1.txt - Notepad
File Edit Format Help
02

PROGRAM PARAMETERS of Site1
Model GX868 Ver GN3H
With 1K FIFO and 1113 receiver board.
At 01:09:00 PM on 17 JAN 03

ACTIVE PARAMETERS:

Site status      Burst
Skan/measure mode Skan/Meas

SYSTEM PARAMETERS:

no label
No message
System Units      ENGLISH
Pressure Units    PSIA
Totalizer Option  Automatic
Equation          Actual Flow only
Supercompress?   Yes
Volumetric Units  Thousands ACF
Volumetric Time   /min
VOL Decimal Digits 0
Totalizer Units   Actual cubic ft
TOT Decimal Digits 0
Mass Flow Units   Pounds
Mass Flow Time    /sec
MDOT Decimal Digits 0
Mass Units        Pounds
Mass Decimal Digits 0

PIPE PARAMETERS:

```

Figure C-17: Printout of Site File

4. Click [Close] once to close the *Site File Operations* window, and a second time to close the *Properties* window and return to the *Meter Browser*.

C.6 Changing Meter Settings

Through PanaView, GC868 users can handle remote programming of the meter. They can:

- Program and change a meter's operating parameters;
- Set up, start, and stop logs;
- Calibrate and test inputs and outputs;
- Clear various files.

To access meter programming:

1. Enter the *New Meter Browser* option from the "File" menu.
2. Expand the network tree until you reach the desired meter.
3. Then expand the meter tree as shown in Figure C-18 below.

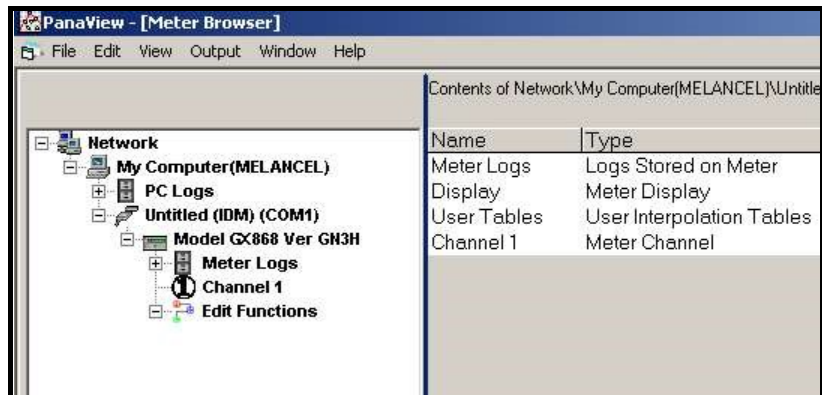

Figure C-18: New Meter Browser with Meter Branch

4. From the meter tree, expand the *Edit Functions* option. The window now appears similar to Figure C-19 below, with a list of available menus. The menus listed are those available on the meter.

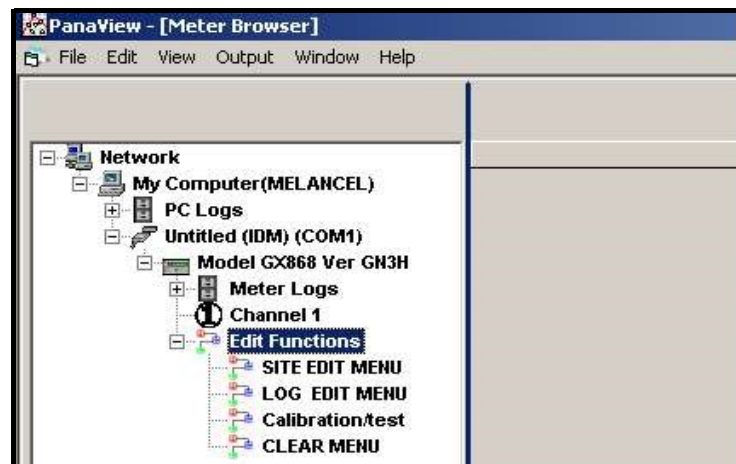

Figure C-19: Meter Tree with Edit Functions Option

5. To open a particular menu, double-click on that menu on the tree. For example, if you double-click on the Site Edit Menu, a window opens similar to Figure C-20 below.

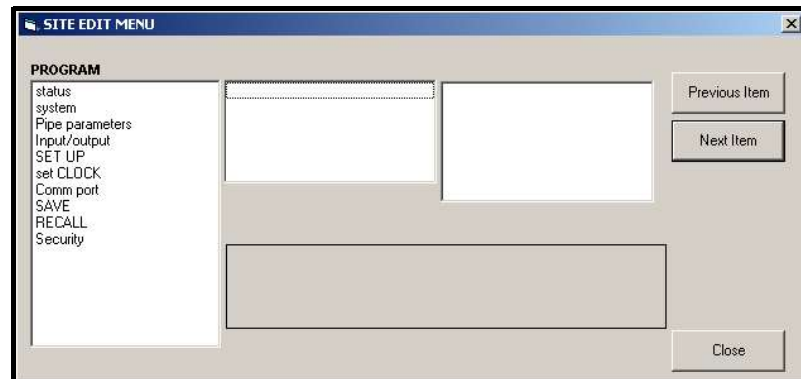

Figure C-20: The Site Edit Menu Window

Note: *The options listed in the left pane correspond to the options available in the GX868 PROGRAM menus. For more information about the options in your instrument program and about appropriate parameters for the GC868, consult the previous chapters in this manual.*

6. To enter a particular option:
 - a. Highlight and double-click on the desired option in the left pane. Figure C-21 below shows the first entry (Transducer Number) in the Pipe parameters option. The title above the center pane lists the current entry, while the center pane displays the available selections for that entry.
 - b. Click on the desired choice; if the entry requires a numeric value, change the value displayed in the right pane.

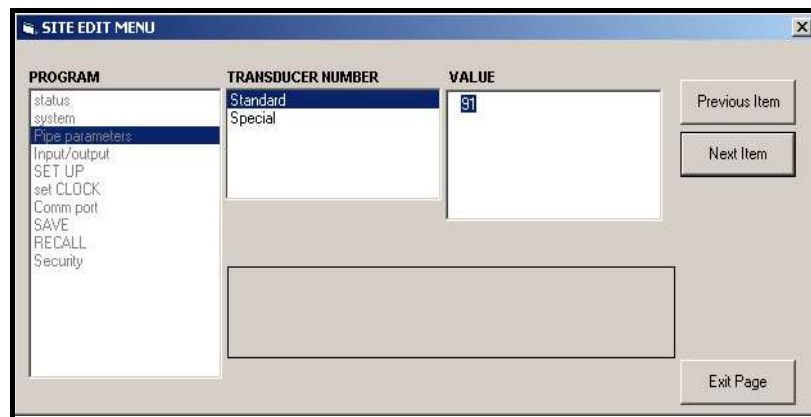

Figure C-21: Pipe Parameters Option in the Site Edit Menu

- c. Do one of the following:

Click on [Next Item] to proceed to the next menu item,

or

Click on [Previous Item] to return back through the menu to a previous item.

Note: *If you click on either [Next Item] or [Previous Item] without changing the settings, the current settings remain unchanged.*

As you step through the menu, the bottom panel lists the current settings you have modified or left unchanged (see Figure C-22 on page C-14). If you modify or step through more than five items, a scroll bar at the right of the panel lets you review the earlier settings.

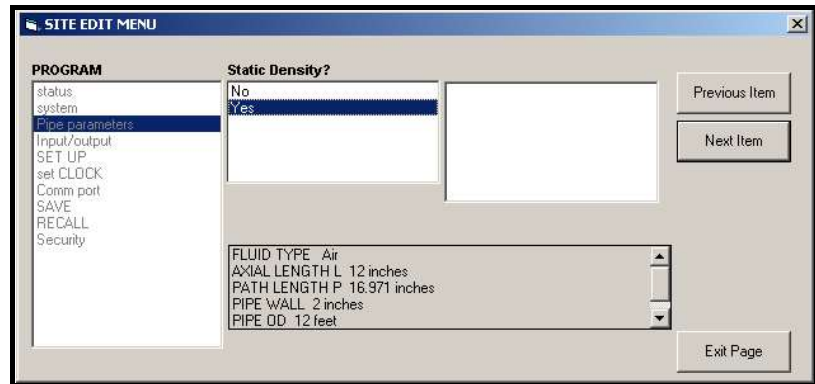

Figure C-22: Site Edit Menu with Current Settings

7. When you have completed entering parameters in a given option, click [Exit Page] to close the option. You can then double-click on another option, or click [Close] to close the window.

You can double-click on another menu to modify its settings, or return to the *New Meter Browser*. For additional PanaView functions, refer to the *PanaView User's Manual*.

[no content intended for this page]

Appendix D. Foundation Fieldbus Communications.

Optional Measurements	D-1
Configuration Utility Setup	D-2
Selecting the Desired Measurements	D-2
Selecting Units for AI Blocks	D-4
Resetting Instrument Totalizers	D-5
Function Block Application	D-6

D.1 Optional Measurements

Foundation Fieldbus provides a means of communicating with the flowmeter. The patent numbers which apply are 5,909,363 and 6,424,872.

This Foundation Fieldbus device supports 2 Analog Input (AI) blocks, which can be configured to supply the following measurements on the network (see Table D-1 below).

Table D-1: Available Measurements Using a 1-Channel GC868

Channel 1	Units	Channel 1	Units	Channel 1	Units
Ch1 Velocity	ft/s or m/s*	Ch1 Mass Flow	MASS_U	Ch1 SSUP	none
Ch1 Act Volumetric	VOL_U	Ch1 Fwd Mass Totals	MTOT_U	Ch1 SSDN	none
Ch1 Std Volumetric	VOL_U	Ch1 Rev Mass Totals	MTOT_U	Ch1 Sound Speed	ft/s or m/s*
Ch1 Fwd Totals	TOT_U	Ch1 #Mass Tot Digits	none	Ch1 Density***	see note
Ch1 Rev Totals	TOT_U	Ch1 Timer	sec	Ch1 Temperature	Deg F or C*
Ch1 #Tot Digits**	none	Ch1 Error Code	none	Ch1 Pressure	PRESS_U

*Metric or English units are determined by the setup of the flowmeter.

**Totalizer digits are available for informational purposes only. Respective totals are automatically scaled by the Tot Digits value selected in the flowmeter setup.

***If the meter is outputting Mole Weight, the unit is "mw", otherwise it is the programmed pressure unit.

VOL_U, TOT_U, MASS_U, MTOT_U and PRESS_U are determined by the units chosen for these measurements in the flowmeter setup. See the instrument User's Manual for the setup of these parameters.

D.2 Configuration Utility Setup

The following is an *example* setup using National Instruments Configuration Utility v3.1.

Figure D-1 below shows the Configuration Utility with a flowmeter on the network (BH Flow-XMT).

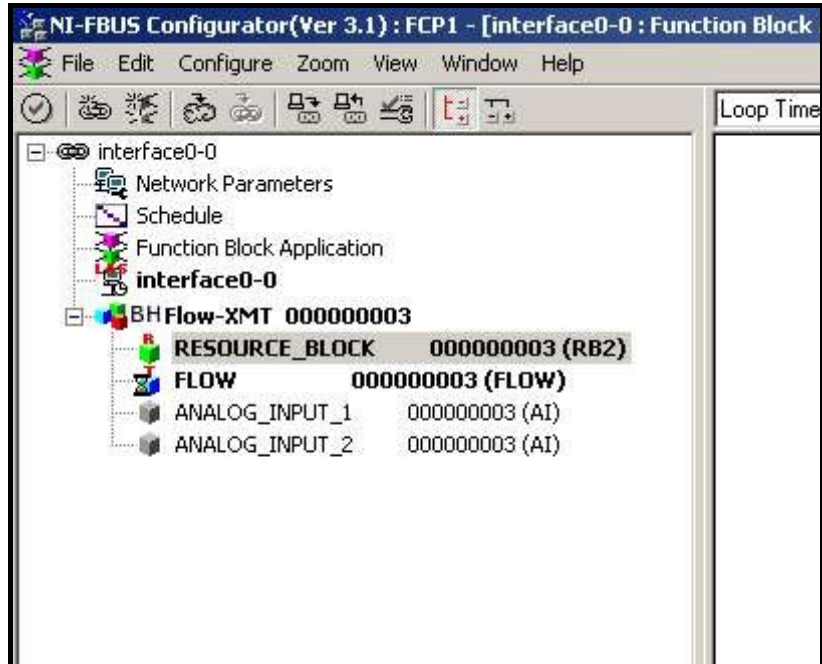

Figure D-1: Configuration Utility Setup Example

Note: *The following procedures assume that the device has been placed in the OOS (out-of-service) mode before executing.*

D.3 Selecting the Desired Measurements

To set the measurement unit for each AI:

1. Double click on the FLOW Transducer Block (in the tree under BHFlow-XMT).
2. Select the Others tab and open the drop down list for the PRIMARY_SELECTOR and SECONDARY_SELECTOR (refer to Figure D-2 on page D-3).
3. Choose the unit from the list (see Figure D-2 on page D-3).

This unit will correspond to the unit that is available in the AI block for network connection. The PRIMARY_SELECTOR unit will correspond to ANALOG_INPUT_1 and the SECONDARY_SELECTOR will correspond to ANALOG_INPUT_2.

- After the desired measurements have been selected for the PRIMARY and SECONDARY SELECTOR, choose the unit system (UNIT_SELECTOR above the PRIMARY_SELECTOR) that has been programmed in the flowmeter (English or SI).

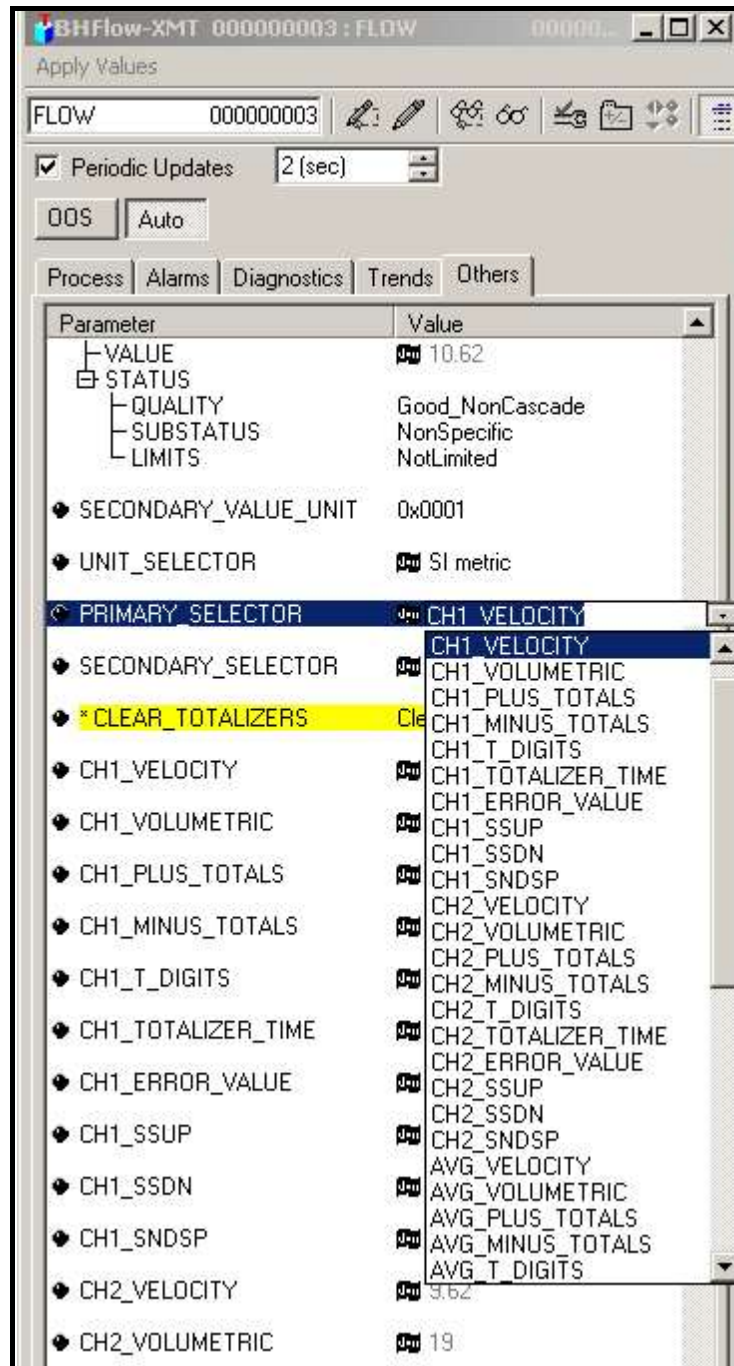

Figure D-2: Primary Selector Drop Down List

D.4 Selecting Units for AI Blocks

To select the units for the individual AI blocks:

1. Double click on the AI block for which you wish to set the units (ANALOG_INPUT_1 or ANALOG_INPUT_2 in the tree under BHFlow-XMT; see Figure D-1 on page D-2).
2. Select the Scaling tab and set the unit for the measurement based on the flowmeter settings.

For example, if the flowmeter was set to use the metric unit system and the PRIMARY_SELECTOR was set to use VELOCITY you would choose m/s for the unit as shown in Figure D-3 below.

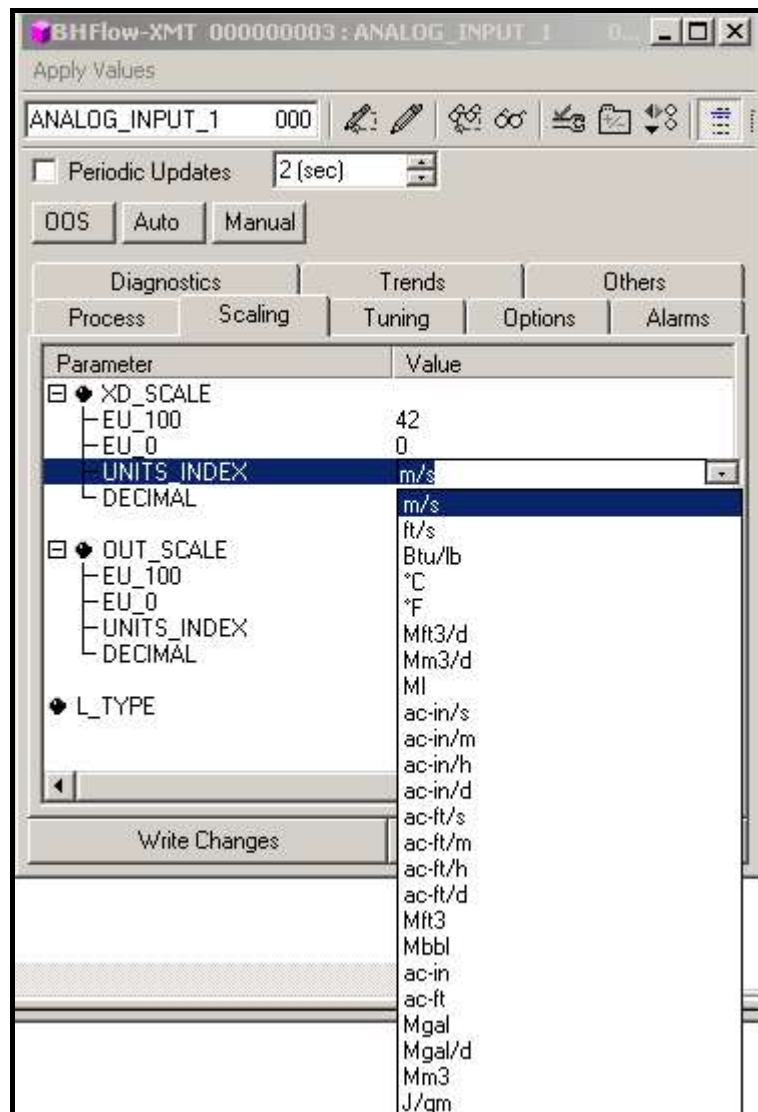

Figure D-3: Units Index Drop Down List

D.5 Resetting Instrument Totalizers

To reset the instrument totalizers:

1. Double click on the FLOW transducer block (in the tree under BHFlow-XMT; see Figure D-1 on page D-2).
2. Select the Others tab and scroll down to the CLEAR_TOTALIZERS listing.
3. Select Clear from the drop down list box (see Figure D-4 below).
4. After the totals have been reset, select Normal from the drop down list box to resume total accumulation.

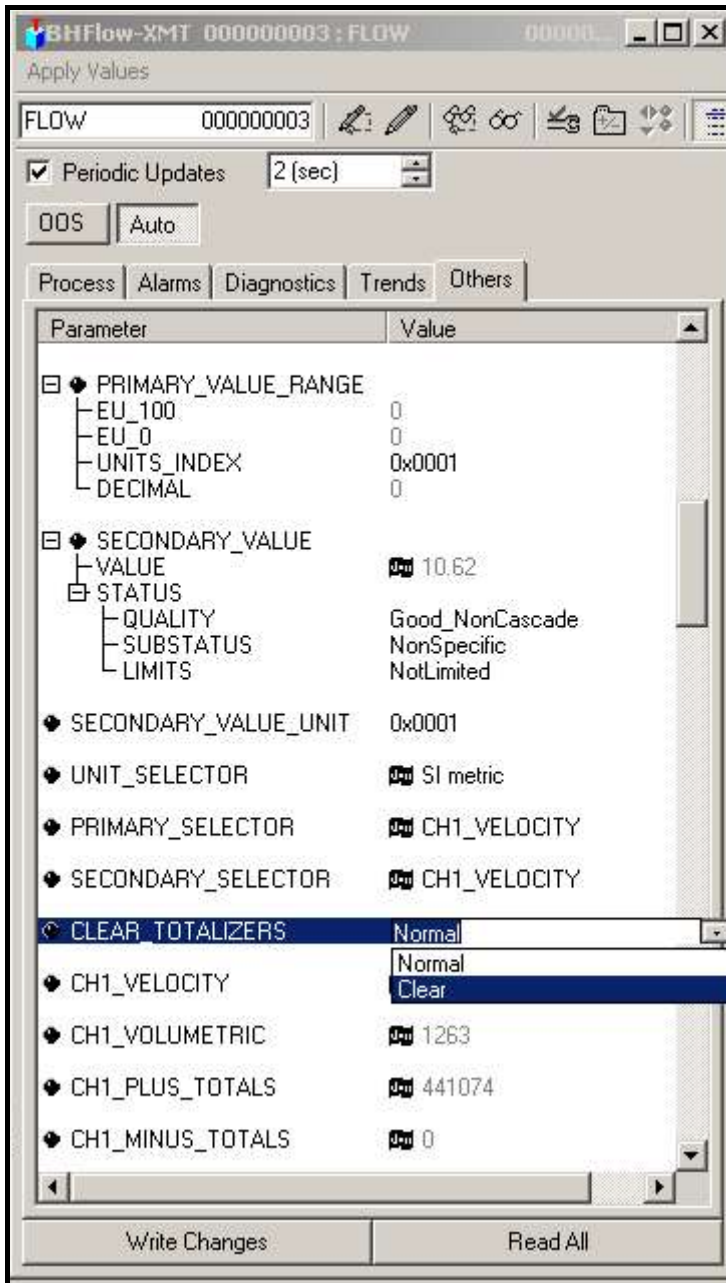

Figure D-4: Clear Totalizers Drop Down List

D.6 Function Block Application

Figure D-5 below is an example setup using the Function Block Application editor. The flowmeter AI blocks, along with the AO and PID of another device on the network, are displayed. We have connected the AI_1 OUT of the flowmeter to the CAS IN of the AO block. We have also connected the AI_2 OUT of the flowmeter to the CAS IN of the PID block.

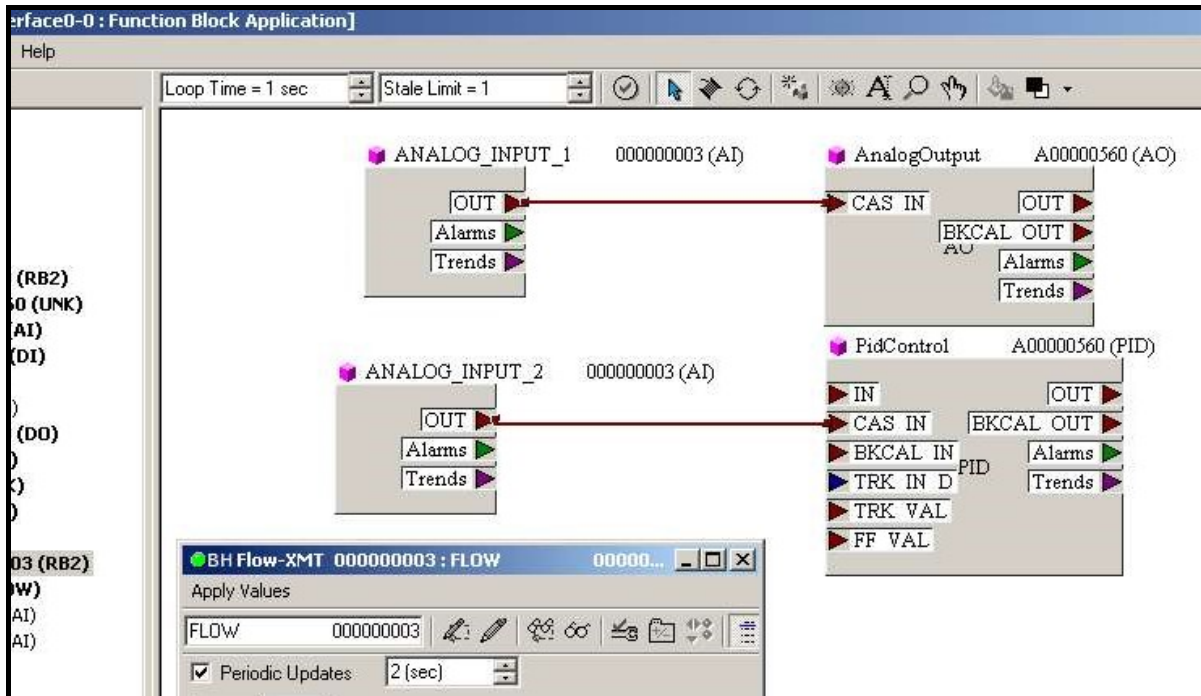

Figure D-5: Function Block Application

[no content intended for this page]

Index

- A**
- Abbreviations, Volumetric Units 1-9
 - ACTIV
 - Menu Map 1-8
 - Submenu 1-8
 - Activating Security 1-30
 - Alarms Card, Setting Up 1-14
 - Analog Inputs Card, Setting Up 1-15
 - Analog Outputs (Slot 0), Setting Up 1-13
 - AVRG Option 1-26, 1-28
 - AVRG Submenu 1-22
- B**
- BACKL
 - Automatic Timeout 2-10
 - Submenu 2-1, 2-10
 - Backlight
 - See BACKL
 - Basic Programming, Min. Requirements 1-8
 - Baud Rate
 - Available Options 1-27, 6-2
 - RS232 Port 6-2
 - Setting 1-27
 - BIG
 - Measurement Parameter Options 2-2
 - Screen Format 2-1
 - Submenu 2-1
 - Burst Mode 1-8, 1-20
- C**
- Clear Site from Meter C-11
 - Clear Totalizers C-9
 - Clearing Data 5-1
 - CLOCK
 - Menu Map 1-26
 - Submenu 1-26
 - CLR Menu Map 5-1
 - COMM
 - Exiting 1-27
 - Menu Map 1-26
 - Submenu 1-26
 - Communications Port, Setting Up C-1
- D**
- Data Record
 - Initial Setup B-2
 - Option Card B-1
 - User Program B-2
 - DATA Submenu 4-1
 - Date, Programming 1-26
 - DISP
 - Menu 2-1
 - Display, Metric or English 1-9
- Displaying Data
- BIG Format 2-1
 - Display Menu 2-1
 - DUAL Format 2-2
 - Graphical Format 2-3
 - Log File 2-4
 - Log File Display Options 2-5, 2-6
 - Log File, Graphical Format 2-6
 - Log File, Numeric Format 2-5
 - Numeric Key Functions 2-9
 - SLEEP Mode 2-10
 - Transducer Signals 2-7
 - Typical SIGNAL Display Screen 2-8
- DUAL
- Screen Format 2-2
 - Submenu 2-1, 2-2
- E**
- Edit Functions Option C-12
 - Edit Menu C-1
 - ERROR
 - Response Options 13
 - Submenu 1-13, 1-1, 3-6
 - Ethernet
 - Setting Up 6-7
 - Setting up with PanaView C-2
- F**
- Foundation Fieldbus
 - Available Measurements D-1
 - Communications D-1
 - Option Card 1-26
 - Function Keys, GRAPH Screen Format 2-3
- G**
- Gas Equation 1-9
 - GRAPH
 - Screen Display Options 2-4
 - Screen Format 2-3
 - Setting Up 2-3
 - Submenu 2-1, 2-3
 - Typical Display Screen 2-3
 - Using Function Keys 2-3
- H**
- Help, On-Line 1-6
 - Hyperterminal 6-3
- I**
- I/O
 - Menu Map 1-12
 - Submenus 1-12
 - IDM-Compatible Meters C-1
 - INIT Submenu 1-22
 - Initial Setup Data Record B-2
 - Instrument Data Manager (IDM) 1-26
- K**
- Keypad
 - Description 1-2
 - Using 1-2

Keys	
Audio Alarm Volume	1-7
Console Control	1-7
Display Backlight	1-7
Display Contrast	1-7
Stopwatch Totalizer	1-7
	L
LOG	
Entering the Submenu	2-4
Menu Map	2-4
Submenu	2-1, 4-4, 5-2
Log File	
Header	3-1
Pages of Memory	3-1
Records	3-1
Logging Data	3-1
Calculating Number of Pages	3-5
Calculating Number of Records	3-5
Circular	3-3
Measurement Parameter Options	3-2
Menu	3-1
Non-Circular	3-3
Time Increment	3-4
	M
Mass Flow Units	
Available Options	1-10
Setting	1-10
Measure Mode	1-8
Measurements, Foundation Fieldbus	D-1
MEM Submenu	3-1, 3-5
Menu Map	
ACTIV Submenu	1-8
CLR	5-1
COMM Submenu	1-26
I/O Submenu	1-12
LOG Submenu	2-4
OPTN Submenu	1-13
PRNTR Submenu	4-7
SAVE Submenu	1-29
SECUR Submenu	1-30
SGNLS Submenu	4-8
STOP Submenu	4-7
Menus, Edit	C-1
Meter Settings, Changing	C-12
MODBUS Register Map	1-28
MODBUS/TCP, Setting Up	6-7
	N
Network ID Number	1-27
Numeric Keys, Displaying SIGNAL Data	2-9
	O
On-Line Help	1-6
Option Card	
Alarms	1-14
Analog Inputs	1-15
Data Record	B-1
RTD Inputs	1-16
Totalizer/Frequency	1-14
	OPTN
Menu Map	1-13
Submenu	1-13
	P
PanaView	1-26
Applications	C-1
Password	
Default	1-30
Entering	1-30
Pipe Wall, Entering	1-12
Plotting Signal	C-8
Printer	
Acceptable Models	4-7
Interface	4-7
Setting Up	4-7
Printing Data	
Live Data, Graphical Format	4-3
Logged Data, Graphical Format	4-5
Logged Data, Numeric Format	4-5
Measurement Parameter Options	4-2
Sample Printout, Live Graphical	4-4
Sample Printout, Live Numeric	4-2
Sample Printout, Logged Graphical	4-5
Sample Printout, Logged Numeric	4-5
Sample Printout, Signal Array	4-8
Sample Printout, Site Data	4-6
Serial Port	4-1
Site File	4-6
PRNT	
Menu	4-1
PRNTR	
Menu Map	4-7
Submenu	4-7
PROG	
Key	1-8
Menu Map	4-6
Submenu	4-6
Properties Option in Edit Menu	C-6
	R
Recalling a Site	1-30
RECLL	
Entering	1-30
Submenu	1-30
RS232, RS485	
See Serial Interface	
RTD Inputs Card, Setting Up	1-16
	S
SAVE	
Entering	1-29
Menu Map	1-29
Submenu	1-29
Save Site Print to PC	C-11
Save Site to Meter	C-10
Save Site to PC	C-10
SECUR	
Entering	1-30
Menu Map	1-30
Submenus	1-30

Serial Communications.....	1-26	Terminal Software	
Baud Rate.....	1-27	Hyperterminal.....	6-3
Network ID Number.....	1-27	Setting Up Windows 3.X.....	6-2
UART Bit Options.....	1-27	Setting Up Windows 9X/NT.....	6-3
Serial Interface		TOTAL Submenu.....	5-1
Configuring RS485 Converter.....	6-5	Totalizer/Frequency Card	
Optional RS485.....	6-3	Setting Up.....	1-14
Panametrics Cables.....	6-1	Transducer Signals	
RS232 Terminal Block Pins.....	6-1	Display Options.....	2-7
RS485 Interface Converter.....	6-4	Displaying.....	2-7
RS485 Multi-Point Wiring.....	6-5	Transducer, Special.....	1-10
RS485 Point-To-Point Wiring.....	6-4		
Setting Up Windows 3.X.....	6-2	U	
Setting Up Windows 9X/NT.....	6-3	Uploading Logs	
Standard RS232.....	6-1	Windows 9X/NT.....	6-3
Uploading Logs in Windows 9X/NT.....	6-3	User Program	
Wiring RS232.....	6-1	Data Record.....	B-2
SETUP		Entering.....	1-8
Entering.....	1-18	Submenus.....	1-1
Submenus.....	1-18		
SGNLS		V	
Menu Map.....	4-8	Volumetric Units	
Submenu.....	4-8	Abbreviations.....	1-9
Signal		Selecting.....	1-9
Graph.....	C-8	Table of Options.....	1-9
Plot.....	C-8		
Reading.....	C-8	Z	
Save.....	C-9	ZERO	
Type.....	C-8	Entering Cutoff Value.....	1-16
Signal Array Data, Printing.....	4-8	Submenu.....	1-16
SIGNL			
Option.....	1-18		
Submenu.....	2-1, 2-7		
Typical Display Screen.....	3-8		
Site Edit Menu.....	C-13		
Site File			
Handling.....	C-9		
Operations.....	C-9		
Saving.....	1-30		
Site Label.....	1-9		
Site Message.....	1-9		
SITE Submenu.....	5-2		
Site, Recalling.....	1-30		
Skam Mode.....	1-8		
SLEEP Submenu.....	2-1, 2-10		
Slot 0			
Analog Outputs.....	1-13		
Setting Up.....	1-13		
Slot Number.....	1-13		
STD Submenu.....	3-1, 3-2		
STOP			
Menu Map.....	4-7		
Submenu.....	3-1, 3-5, 4-7		
System Security.....	1-30		
SYSTEM Submenu.....	1-9		
		T	
T,P			
Entering Values.....	1-16		
Submenu.....	1-16		

[no content intended for this page]

Customer Support Centers

U.S.A.

The Boston Center
1100 Technology Park Drive
Billerica, MA 01821

U.S.A.

Tel: 800 833 9438 (toll-free)
978 437 1000

E-mail: panametrictechsupport@bakerhughes.com

Ireland

Sensing House
Shannon Free Zone East
Shannon, County Clare
Ireland

Tel: +353 (0)61 470291

E-mail: panametrictechsupport@bakerhughes.com

Copyright 2023 Baker Hughes company.
This material contains one or more registered
trademarks of Baker Hughes Company and its
subsidiaries in one or more countries. All third-party
product and company names are trademarks of their
respective holders.

BH014C31 EN G (05/2023)

Baker Hughes 